

## **APCO SURGE RELIEF ANGLE VALVES (SRA)**

### **Design & Construction**

APCO Surge Relief Angle Valves (SRA) are designed to limit surge pressure and the potential damage to the pump system. The surge relief valve is normally closed. The Surge Relief Valve protects the system by opening when the system pressure exceeds the relief pressure setting of the valve disc. As the disc opens, the surge pressure is spilled and dissipated through the valve. The valve is designed with a smooth flow area and minimal obstructions for efficient surge relief.

The Surge Relief Angle Valve (SRA) is an elbow body style surge relief valve that is held normally closed by a compression spring or system of nested springs. They are available in sizes 2-16" (50-400mm) and with pressure relief ratings up to 200 psi (1380 kPa). SRA Valves are available in ductile iron with seats of Acrylonitrile-Butadiene (NBR), Terpolymer of Ethylene, Propylene and A Diene (EPDM) or Fluoro Rubber (FKM).



**Surge Relief Angle Valve (SRA)**

## APCO Surge Relief Valves Provide Surge Protection

Pressure surges occur when fluid velocity changes. APCO Surge Relief Valves limit the surge pressure magnitude commonly associated with sudden pump shutdown in fluid piping systems.

The surge relief valve is typically installed downstream of the check or pump control valves on the pump discharge header with the valve inlet connected to the side outlet of a tee and the valve outlet piped to the sump.

The normally closed surge relief valve opens quickly when the system pressure rises (red line) above its adjustable relief pressure setting (dashed line) allowing fluid to be discharged from the system through the open surge relief valve to atmosphere. While the surge relief valve is open, the system is no longer contained, fluid compression is limited and surge pressure is controlled (green line). The valve will remain open as long as the system pressure exceeds the valve's relief pressure setting. The valve will slowly begin to close at an adjustable rate as the surge pressure subsides and the system pressure falls below the valve's relief pressure setting.

## Typical Pressure Versus Time Graph With and Without a Surge Relief Valve

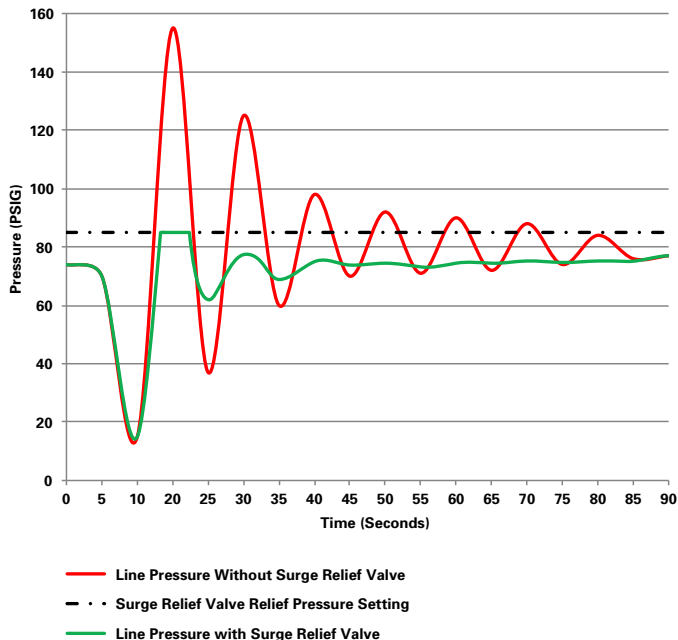

## Incremental Pressure vs. Flow Velocity

The "Incremental Pressure vs. Flow Velocity" graph provides an estimate of incremental pressure rise due to surge for different pipe materials in typical sizes. The graph assumes that the flow velocity is changed in less than one surge period, or in less time than it takes for the surge wave to travel from the source to the end of the system and back.

## Incremental Pressure vs. Flow Velocity

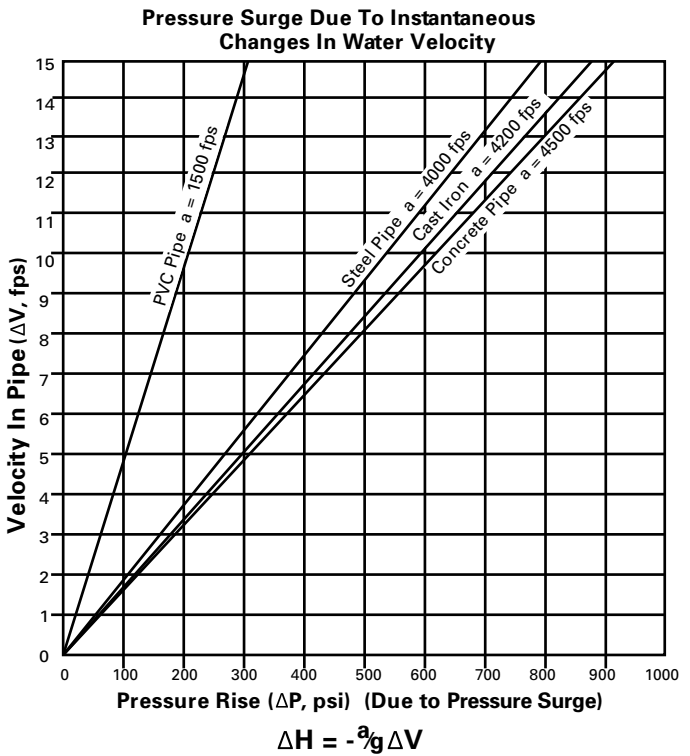

# Surge Relief Valve Sizing

This sizing chart is based upon current engineering practice and offered as a general guideline for use on simple pipelines with standard operating conditions. Other factors, such as line length, pipe wall thickness, and pipe material have an effect on potential surge magnitude. Contact DeZURIK/APCO to discuss valve solutions for your particular pumping system.

## Sizing Steps

1. Determine Maximum Pipeline Velocity ( $V_L$ ) in fps.
2. Determine Maximum Allowable Line Pressure ( $P_L$ ) in psi. Suggested Maximum Allowable Line Pressure is 15% above normal pumping pressure, or rated pump pressure, to minimize pipe fatigue.
3. Calculate  $V_L/P_L$ .
4. Referring to the graph, read vertically up from  $V_L/P_L$  on the bottom scale to the intersection with the diagonal line representing the pipeline diameter then go horizontally over to the left for the Surge Relief Valve size. Round up to the next largest valve size.

## Example

1. Data:
  - 12 inch diameter pipeline,
  - 3000 GPM maximum flow,
  - 170 psi maximum allowable system pressure
2. Divide velocity by pressure:  
 $V_L/P_L = 8.5 \text{ fps}/170 \text{ psi} = 0.05$
3. From 0.05 on the bottom scale read vertically up to the intersection with the diagonal line representing a 12" diameter pipeline.
4. Read horizontally over to the point on the vertical scale that determines valve size and select a 4" size for this example.

## Sizing Graph

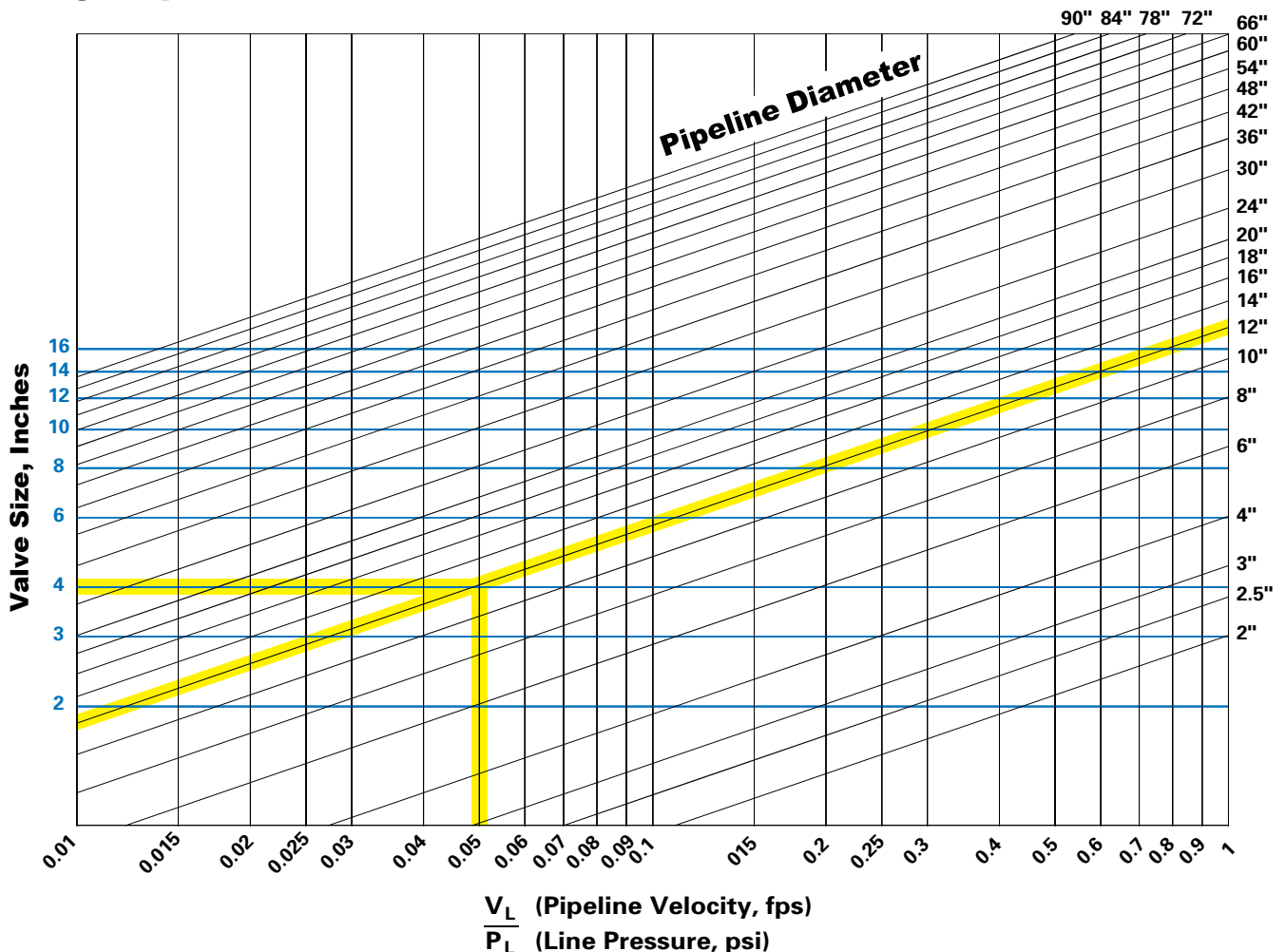

# Materials of Construction

Item	Description	Material
A1	Body	Ductile Iron, ASTM A536 Grade 65-45-12
A2	Cover	Ductile Iron, ASTM A536 Grade 65-45-12
A3	Cover O-Ring	Acrylonitrile-Butadiene (NBR)
		Terpolymer of Ethylene, Propylene and A Diene (EPDM)
		Fluoro Rubber (FKM)
A4	Lower Shaft Bushing	Bronze
A5	Body Seat	Aluminum Bronze C95200
		316 Stainless Steel, ASTM A240
A6	Disc Seat	Acrylonitrile-Butadiene (NBR)
		Terpolymer of Ethylene, Propylene and A Diene (EPDM)
		Fluoro Rubber (FKM)
A7	Piston	Carbon Steel, ASTM A108, Grade 1018 or ASTM A36
A8	Piston Seal	PTFE
A9	Piston Seal Energizing O-Ring	Acrylonitrile-Butadiene (NBR)
A10	Disc	Carbon Steel, ASTM A108, Grade 1018
		316 Stainless Steel, ASTM A240/A276
A11	Lower Shaft	303 Stainless Steel, ASTM A582, Condition A
A12	Upper Shaft	303 Stainless Steel, ASTM A582, Condition A
A13	Cylinder Chamber Cap	Carbon Steel, ASTM A108, Grade 1018 or ASTM A36
A14	Cylinder Chamber Cap O-Ring	Acrylonitrile-Butadiene (NBR)
A15	Cylinder Chamber Cap Screws	Steel
A16	Spring Pressure Plate Guide	Carbon Steel, ASTM A108, Grade 1018 or ASTM A36
A17	Spring Compression Top Flange	Carbon Steel, ASTM A108, Grade 1018 or ASTM A36
A18	Spring Compression Guide	Carbon Steel, ASTM A108, Grade 1018 or ASTM A36; or Ductile Iron, ASTM A536 Grade 65-45-12
A19	Anti-Rotation Set Screw	316 Stainless Steel
A20	Pipe Assembly Lower Screws	Alloy Steel, Zinc Plated
A21	Pipe Assembly Upper Screws	Alloy Steel, Zinc Plated
A22	Spring Compressor	Alloy Steel, Zinc Plated
A23	Spring Compression Pipe Assembly	Steel
A24	Compression Shipping	Alloy Steel, ASTM A125
A25	Bushing O-Ring	Acrylonitrile-Butadiene (NBR)
		Fluoro Rubber (FKM)
A26	Lower Shaft O-Ring	Acrylonitrile-Butadiene (NBR)
		Fluoro Rubber (FKM)
A27	Upper Shaft O-Ring	Acrylonitrile-Butadiene (NBR)
A28	Rod Wiper	Polyethylene
A29	Inspection Hole Pipe Plug	316 Stainless Steel
A30	Body Seat Retaining Screw	316 Stainless Steel
A31	Disc Seat Retaining Ring	316 Stainless Steel, ASTM A240/A276
A32	Disc Seat Retaining Screw	316 Stainless Steel
A33	Body Seat O-Ring	Acrylonitrile-Butadiene (NBR)
		Terpolymer of Ethylene, Propylene and A Diene (EPDM)
		Fluoro Rubber (FKM)
A34	Cover Screws	Alloy Steel, Zinc Plated
A35	Flow Control Valve	Steel
A36	Shaft Collar	Alloy Steel
A37	Needle Thrust Bearing (6-16")	Steel
A38	Lock Nut	Alloy Steel, Zinc Plated
A39	Lower Shaft Retaining Ring	Steel
A40	Bushing Retaining Ring	Steel
A41	Piston Assembly Screw	Alloy Steel
A42	Mechanical Counter	Steel/Plastic
A43	Mechanical Counter Mounting Screws	18-8 Stainless Steel
A44	Mechanical Counter Hook (with Lock Nut)	Carbon Steel, Zinc Plated
A45	Mechanical Counter Wire	302 Stainless Steel
A46	Pipe Assembly Lower Screw Washer	Carbon Steel, Zinc Plated
A47	Pipe Assembly Upper Screw Washer	Carbon Steel, Zinc Plated
A48	Spring Compression Washer	Carbon Steel, Zinc Plated
A49	Oil Fill Pipe Plug	Steel
A97	Data Plate	316 Stainless Steel
A98	Drive Screw	18-8 Stainless Steel

# Principle of Operation

The Surge Relief Angle Valve (SRA) is held normally closed by a compression spring(s) (A24). When the system pressure rises above the relief pressure setting of the spring(s), the disc (A10) moves quickly to the open position, raising the piston (A7) inside the integral oil cylinder of the cover (A02). This allows hydraulic oil from the top of the piston to flow freely through the flow control valve to the bottom of the piston.

As the system pressure subsides below the relief pressure setting, the surge relief valve closes at a slow adjustable rate. The spring(s) moves the disc toward the seated position as oil is metered from the bottom of the piston by the adjustable flow control valve (A35) to the top of the piston.

## Closing Speed Adjustment

The flow control valve (A35) allows free oil flow in the direction of opening and controlled flow in the direction of closing to allow fast open and slow close of the surge relief valve. Closing speed can be adjusted to suit the system.

## Pressure Setting

The relief pressure setting (valve opening pressure) is controlled by the amount of spring compression imposed by the spring compression guide (A18) as set by the spring compressor (A22). The relief pressure setting is factory set but can be adjusted, within limits, by rotating the spring compressor (A22). The lock nut (A38) is tightened to maintain the setting.

## Field Installation

The Surge Relief Valve should be installed with the resilient seat of the disc facing the system pressure. The valve outlet must be piped to the sump or into a spillway for discharge to atmosphere. Surge Relief Angle Valves may be installed vertically or horizontally.

## Mechanical Cycle Counter

The Mechanical Counter (A42) logs the number of surge events in the application.

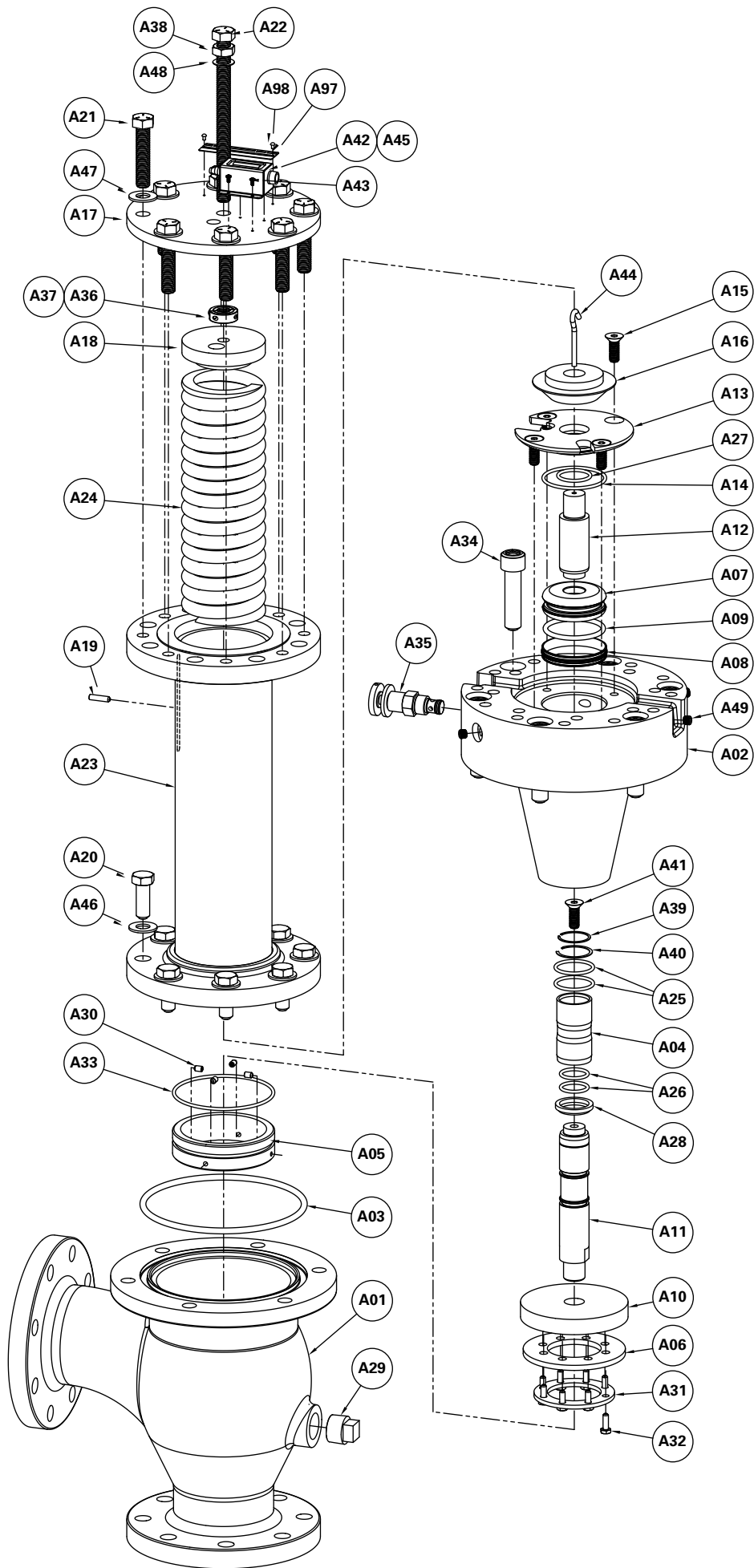

# Valve Selection

## Shut-Off Capabilities

Resilient Seats	Drip tight shut-off
-----------------	---------------------

## Temperature Ratings

Seat Material	Temperature Rating*
All Seats	-20 to 150°F (-20 to 65°C)

\*Higher temperature ratings available on application.

## Weights

Valve Size	Relief Pressure Set Point (psi)	Valve Weight (lbs/kg)
2" 50mm	30-135	<u>154</u> 70
	140-200	<u>168</u> 77
3" 80mm	30-60	<u>204</u> 93
	65-180	<u>219</u> 100
	185-200	<u>352</u> 160
4" 100mm	30 Only	<u>219</u> 100
	35-95	<u>233</u> 106
	100-200	<u>291</u> 133
6" 150mm	30-35	<u>402</u> 183
	40-110	<u>459</u> 209
	115-200	<u>699</u> 318
8" 200mm	30-60	<u>591</u> 269
	65-200	<u>830</u> 377
10" 250mm	30-35	<u>749</u> 340
	40-120	<u>989</u> 449
	125-200	<u>1800</u> 817
12" 300mm	30-55, 75-80	<u>1290</u> 586
	60-70, 85-200	<u>2090</u> 949
14" 350mm	30-50	<u>2210</u> 1003
	55-150	<u>3010</u> 1366
	155-200	<u>4090</u> 1856
16" 400mm	30-40	<u>2030</u> 922
	45-110	<u>2840</u> 1289
	115-200	<u>3910</u> 1775

## Applicable Standards

**DeZURIK SRA Valves are designed and/or tested to meet the following standards:**

ASME B16.1 (ASA B16.1)	Cast Iron Pipe Flanges and Flanged Fittings, 125 lbs. Conforms to related flange drilling dimensions.
ASME B16.5	Carbon Steel Flanges and Flanged Fittings, 150 lbs. Conforms to related flange drilling dimensions.
ASME B16.42	Ductile Iron Pipe Flanges and Flanged Fittings. Conforms to Class 150.

## Pressure Ratings (Ambient Temperature)

Valve Style	Valve Size	Maximum Pressure*
Surge Relief Angle Valve (SRA)	2-16" 50-400mm	200 psi CWP 1380 kPa CWP

\*Contact DeZURIK for higher pressures and larger sizes

# Ordering

To order, simply complete the valve order code from information shown.  
An ordering example is shown for your reference.

## Valve Style

Give valve style code as follows:

SRA = Surge Relief Angle Valves

## Valve Size

Give valve size code as follows:

2	=	2"	(50mm)	10	=	10"	(250mm)
3	=	3"	(80mm)	12	=	12"	(300mm)
4	=	4"	(100mm)	14	=	14"	(350mm)
6	=	6"	(150mm)	16	=	16"	(400mm)
8	=	8"	(200mm)				

## Body Style

Give body style code as follows:

3000A = Angle Style Surge Relief Valve

## End Connection

Give end connection code as follows:

F1 = Flanged ASME 125/150 Inlet & Outlet

## Body Material

Give body material code as follows:

DI = Ductile Iron

## Relief Pressure Setting

Give relief pressure setting point code as follows:

30P = 30 psi	120P = 120 psi
35P = 35 psi	125P = 125 psi
40P = 40 psi	130P = 130 psi
45P = 45 psi	135P = 135 psi
50P = 50 psi	140P = 140 psi
55P = 55 psi	145P = 145 psi
60P = 60 psi	150P = 150 psi
65P = 65 psi	155P = 155 psi
70P = 70 psi	160P = 160 psi
75P = 75 psi	165P = 165 psi
80P = 80 psi	170P = 170 psi
85P = 85 psi	175P = 175 psi
90P = 90 psi	180P = 180 psi
95P = 95 psi	185P = 185 psi
100P = 100 psi	190P = 190 psi
105P = 105 psi	195P = 195 psi
110P = 110 psi	200P = 200 psi
115P = 115 psi	

Spring adjustment ranges are listed by valve size  
in the instruction manual.

## Trim Combination

### Disc Material

Give disc material code as follows:

CS = Carbon Steel  
S2 = 316 Stainless Steel

### Body Seat Material

Give body seat material code as follows:

S2 = 316 Stainless Steel  
ALB = Aluminum Bronze

### Disc Seat Material

Give disc seat material code as follows:

NBR = Acrylonitrile-butadiene  
EPDM = Terpolymer of Ethylene Propylene & A Diene  
FKM = Fluoro Rubber

## Options

Give option code as follows:

SB16 = 316 Stainless Steel Bolting  
Coatings = Special Coatings Available. Contact DeZURIK

## Accessories

Give accessories code as follows:

SEL45 = (1) Limit Switch DPDT (AB 802B-CSAD1XSXC3)  
SEL30 = (1) Proximity Switch SPDT (GO 73-13526-B2)

## Ordering Example:

SRA,8,3000A,F1,DI,55P,CS-S2-NBR\*

# Dimensions

Valve Size	Dimensions			Relief Pressure Set Point (psi)	D
	A	B	C		
2" 50mm	6.50 165	4.50 114	3.50 89	30-135	26.94 684
				140-200	31.81 808
3" 80mm	7.75 197	5.25 133	4.25 108	30-60	29.44 748
				65-180	34.31 871
				185-200	41.13 1045
4" 100mm	9.00 229	5.25 133	5.13 130	30 Only	29.81 757
				35-95	34.69 881
				100-200	41.50 1054
6" 150mm	11.50 292	6.75 171	6.38 162	30-35	38.06 967
				40-110	44.88 1140
				115-200	54.00 1372
8" 200mm	14.00 356	8.63 219	7.63 194	30-60	49.13 1248
				65-200	58.25 1480
10" 250mm	16.50 419	9.50 241	9.94 252	30-35	53.38 1356
				40-120	62.50 1588
				125-200	75.06 1907
12" 300mm	19.00 483	10.50 267	10.94 278	30-55, 75-80	66.25 1683
				60-70, 85-200	78.81 2002
14" 350mm	21.50 546	11.75 298	13.94 354	30-50	70.00 1778
				55-150	82.56 2097
				155-200	83.31 2116
16" 400mm	24.00 610	11.75 298	14.44 367	30-40	75.25 1911
				45-110	87.81 2230
				115-200	88.56 2249

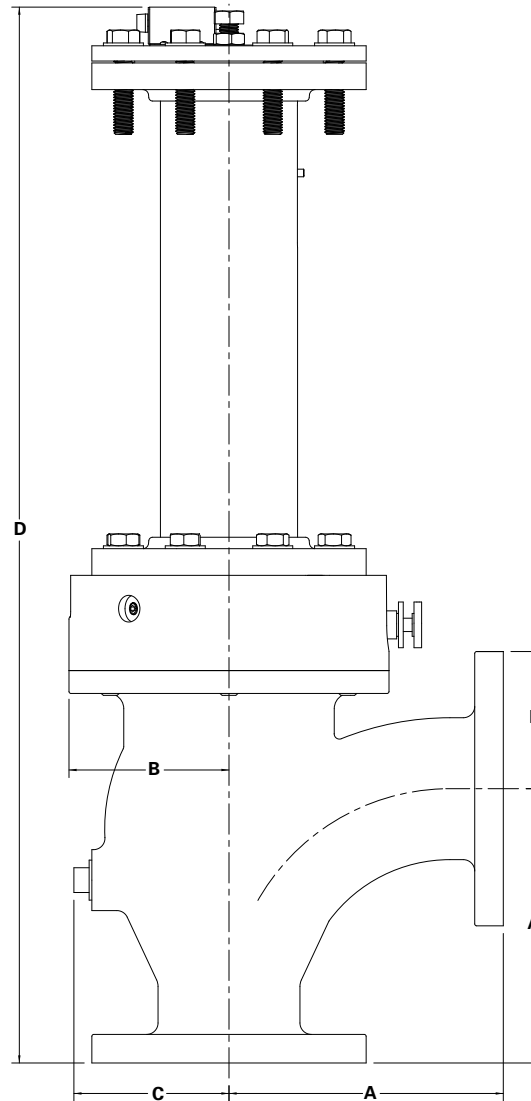

## Sales and Service

For information about our worldwide locations, approvals, certifications and local representative:

**Web Site:** [www.dezurik.com](http://www.dezurik.com) **E-Mail:** [info@dezurik.com](mailto:info@dezurik.com)



250 Riverside Ave. N. Sartell, Minnesota 56377 • Phone: 320-259-2000 • Fax: 320-259-2227

*DeZURIK, Inc. reserves the right to incorporate our latest design and material changes without notice or obligation. Design features, materials of construction and dimensional data, as described in this bulletin, are provided for your information only and should not be relied upon unless confirmed in writing by DeZURIK, Inc. Certified drawings are available upon request.*