

JTL SPECTRUM MULTI-PURPOSE FULL FLOW BALL VALVES

Suitable for a wide range of **chemical** applications, including industrial and agricultural chemicals* **and potable and non potable water**



The JTL Spectrum ball valve range is manufactured from robust Glass Reinforced Polypropylene, PTFE seats, FKM (commonly referred to as Viton™) seals and EPDM Thermoplastic Elastomer seals.

Incorporating a special feature unmatched by its competitors, the shaft is fitted with 2 o-rings of differing materials and colours for ease of identification. FKM in brown and EPDM in black. The combination of these two materials provides coverage over a broader spectrum of chemical applications, where possible leakage could occur through the shaft in standard valves.

Vacuum tested in accordance with AS3688:2016 - Section 4.10 (Vacuum Test for Leaktightness of Joints, Appendix M) and also having attained approval to the latest Australian/ NZ Standard for drinking water, this is truly a multi-purpose valve. Whatever your usage requirements, use JTL Spectrum multi-purpose valves to mitigate your risk.

- FULL FLOW - non directional
- AS/NZS 4020:2018 approved
- Vacuum tested in accordance with AS3688
- Excellent chemical resistance
- UV resistant
- Corrosion resistant
- Ergonomic removable handle
- 90° on/off action
- Pressure rating: up to 1600 kPa @ 20° C
- Operating temperature: > 0° C < 60° C
- Lilac handle option for grey water
- Date stamped body for traceability
- 100% individually leak tested
- Available with NPT threads - MOQs apply
- Supplied on hang sell cards including product information and barcode. Bulk option available
- Over 30 years of design experience incorporated in this valve.

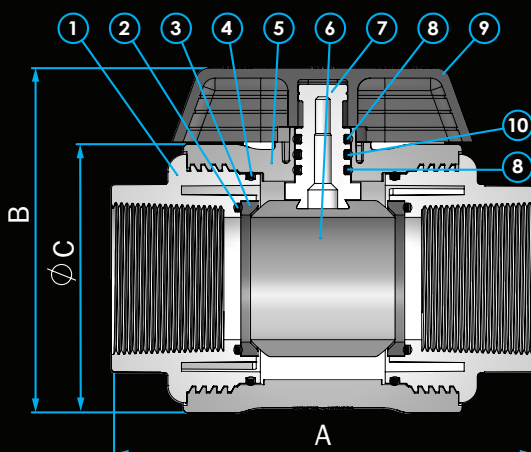

Registered Design: 201813637
Design Patent Pending

VALVE SIZE	15mm	20mm	25mm	32mm	40mm	50mm
(BSPT)	1/2"	3/4"	1"	1 1/4"	1 1/2"	2"
(FI x FI)	JBV15	JBV20	JBV25	JBV32	JBV40	JBV50
HANDLE COLOUR: GREY = General Use LILAC = Grey Water Identification						

DIM (mm)	15mm	20mm	25mm	32mm	40mm	50mm
A (mm)	98	98	112	124	142	170
B (mm)	82	82	91	105	118	138
C (mm)	58	58	67	79	90	108

VALVE PART	BODY (1 & 5)	STEM (7)	HANDLE (9)	SEATS (3)	BALL (6)	SEALS (2, 4 & 8)
MATERIALS	GRPP	GRPP	GRPP	PTFE	GRPP	FKM/EPDM (10)

NB. 15mm and 20mm valves have two seals in the shaft - one FKM (8) and one EPDM (10)
25mm through to 50mm valves have three seals in the shaft - two FKM (8) and one EPDM (10)
NB. Apply sufficient PTFE tape or approved sealant to all thread joints to ensure a watertight seal

AS/NZS 4020:2018 approved by: 

* Chemical resistance varies dependent on type of chemical. For more information see:
www.plasticsintl.com/chemical-resistance-chart
www.graco.com/au/en/products/ad/chemical-compatibility

JTL

TECHNICAL SPECIFICATIONS

Body / Ball / Shaft / End Caps

Glass Reinforced Polypropylene (GRPP)

- Offers good resistance to non-oxidizing acids and bases, fats and most organic solvents
- At elevated temperatures Polypropylene can dissolve in nonpolar solvents such as Xylene, Tetralin and Decalin
- The low melting point of Polypropylene is 160°C (320°F)
- Low temperature threshold: Polypropylene becomes brittle below 0°C
- NOT compatible with strong oxidants.

Ball Seats

Polytetrafluoroethylene (PTFE)

- PTFE is the most versatile plastic in terms of chemical compatibility
- Highly resistant to most acids, alcohols, detergents and solvents
- Ideal for use with reactive and corrosive materials
- The melting point of PTFE is 327°C (620°F)
- Low temperature threshold: maintains high strength, toughness and self-lubrication as low as -286°C (-450°F)
- Good flexibility at -79°C (-110°F)
- NOT compatible with certain alkali metals and fluorinating agents such as Xenon, Difluoride and Cobalt (111) fluoride.

O-Rings

FKM (VITON™)

- The range of chemicals which FKM is resistant against is one of the broadest of all the elastomers. It also has a high temperature tolerance and chemical resistance rating
- It is a synthetic rubber that resists many hydrocarbons, biodiesel and petrochemicals
- Excellent resistance to oils, fuels, lubricants and most mineral acids
- Extremely low permeability to a broad range of substances, including oxygenated automotive fuels
- Resistant to aliphatic hydrocarbons that dissolve other rubbers
- Exceptionally good resistance to compression set even at high temperatures
- Exceptionally good resistance to atmospheric oxidation, sun and weather
- Excellent resistance to fungus and mold
- The range of chemicals in which FKM is resistant is so broad it is far easier to just list the few chemicals in which FKM will be chemically attacked or swollen:
 - in general, low molecular weight ketones and esters will swell a vulcanizate of FKM. In fact, ketones such as methyl ethyl ketones are used as solvents for FKM (uncured). The more polar a material the more likely it will swell FKM
 - amines affect FKM differently from ketones and esters. Generally, amines will react with the polymer backbone and result in embrittlement of the vulcanizate
- NOT compatible with acetone, esters, amines, organic acids, MEK, ethyl acetate and highly polar chemicals.

EPDM Rubber (Ethylene Propylene Diene Monomer)

- EPDM is a synthetic rubber, derived from polyethylene. Rubbers with saturated polymer backbones, such as EPDM, have much better resistance to heat, light and ozone than un-saturated rubbers such as natural rubber.
- EPDM is compatible with polar substances, eg. fireproof hydraulic fluids, ketones, hot and cold water, and alkalis.
- EPDM exhibits excellent resistance to heat, ozone, steam and weather. Service temperature: -50°C (-58°F) to 150°C (302°F)
- NOT compatible with most hydrocarbons, such as oils, kerosene, aromatic, gasoline, as well as halogenated solvents.



GLOBAL CLAMPS PTY LTD

Phone: +61 3 9888 0175
Email: info@globalclamps.com.au
Web: www.globalclamps.com.au



RGD CORPORATION PTY LTD

Phone: +61 8 9358 1466
Email: sales@rgdcorp.com.au
Web: www.rgdcorp.com.au

Local Dealer:

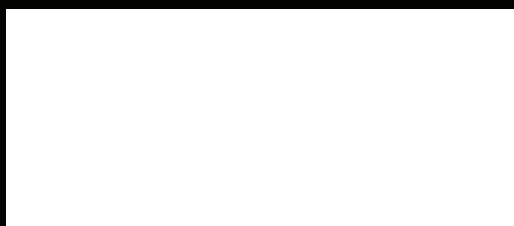

Disclaimer:

The information contained in this brochure is for general information purposes only. The information is provided by JTL Australia Pty Ltd. We try to keep the information up to date and correct, but we cannot and do not in any way guarantee or give any assurances as to the completeness, accuracy, reliability, sustainability or availability of the information provided, or as to products, services, or related graphics contained in this brochure or on our website for any purpose. All information is of a general nature and you must carry out your own research and investigations to satisfy yourself of the suitability or appropriateness of any products(s) for your own particular purpose or intended use.

We will not be liable for any loss or damage, indirect or consequential, and whether arising from loss of materials, time, or profits arising out of, or in connection with, the use of this information.

Spect_MPBV_20201209

JTL
JTL Australia Pty Ltd