

DeZURIK REPAIR KIT – CYLINDER ACTUATOR FOR KNIFE GATE VALVES



Instruction **D11045**
April 2022

Instructions

These instructions are for use by personnel who are responsible for the installation, operation and maintenance of DeZURIK valves, actuators or accessories.

Safety Messages

All safety messages in the instructions are identified by a general warning sign and the signal word CAUTION, WARNING or DANGER. These messages indicate procedures to avoid injury or death.

Safety label(s) on the product indicate hazards that can cause injury or death. If a safety label becomes difficult to see or read, or if a label has been removed, please contact DeZURIK for replacement label(s).

⚠WARNING

Personnel involved in the installation or maintenance of valves should be constantly alert to potential emission of pipeline material and take appropriate safety precautions. Always wear suitable protection when dealing with hazardous pipeline materials. Handle valves which have been removed from service with suitable protection for any potential pipeline material in the valve.

Inspection

Your DeZURIK product has been packaged to provide protection during shipment; however, items can be damaged in transport. Carefully inspect the unit for damage upon arrival and file a claim with the carrier if damage is apparent.

Parts

Replaceable wear parts are listed on the assembly drawing. These parts can be stocked to minimize downtime. Order parts from your local DeZURIK sales representative or directly from DeZURIK. When ordering parts please provide the following information:

If the valve has a data plate: please include the 7-digit part number with either 4-digit revision number (example: 9999999R000) or 8-digit serial number (example: S1900001) whichever is applicable. The data plate will be attached to the valve assembly. Also, include the part name, the assembly drawing number, the balloon number and the quantity stated on the assembly drawing.

If there isn't any data plate visible on the valve: please include valve model number, part name, and item number from the assembly drawing. You may contact your local DeZURIK Representative to help you identify your valve.

DeZURIK Service

DeZURIK service personnel are available to maintain and repair all DeZURIK products. DeZURIK also offers customized training programs and consultation services. For more information, contact your local DeZURIK sales representative or visit our website at DeZURIK.com.

Table of Contents

Description	4
Cylinder Types	4
Type A Cylinder Assembly	5
Type B Cylinder Assembly	6
Type C Cylinder Assembly	7
Type D Cylinder Assembly	8
Type E Cylinder Assembly	9
Lubrication	10
Adjustments	10
Aligning the Cylinder	10
Valve Support	10
Cylinder Stroke Adjustment (if applicable)	11
Piston Rod Packing Adjustment (Fig. 1A)	11
Cartridge Rebuild for Type D Cylinders (Fig. 1D)	12
Disassembling the cartridge for Type D Cylinders	12
Reassembling the Cartridge for Type D Cylinders	12
Cartridge Rebuild for Type E Cylinders (Fig. 1E)	13
Disassembling the cartridge for Type E Cylinders	13
Reassembling the Cartridge for Type E Cylinders	13
Cartridge Assembly Replacement for Type D & E Cylinders (Fig. 1D & 1E)	14
Cylinder Inspection for all Cylinder Types	14
Disassembling the Cylinder	14
Assembling the Cylinder	16
Troubleshooting	17

Description

The cylinder used with DeZURIK Knife Gate Valves is a pneumatic double-acting cylinder that has a recommended supply pressure between 60 and 100 psi. Cylinder pressure should never exceed 100 psi; cylinder can operate at less than 60 psi when valve thrust requirements allow. Use proper cylinder sizing to determine operating pressure.



WARNING!

This cylinder is a pressure vessel. Pressure in the cylinders can cause personal injury or equipment damage. Release pressure from both ends of the cylinder before servicing.

Cylinder Types

Over time, DeZURIK cylinders have evolved to fit with a wide range of products. There are five types of cylinder actuators which are described on the following pages:

1. Type A Packing Gland type;
2. Type B Cylinder Actuator for UNV and PGV Ported Gate Valves;
3. Type C General type;
4. Type D General type with cartridge
5. Type E. Refer to Figures 1A thru 1E to identify the type of pneumatic cylinder that is being serviced.

This instruction includes procedures for replacing parts on the five DeZURIK Cylinder types. Note that not all parts included in the kit will be used to repair all cylinder types.

Type A Cylinder Assembly

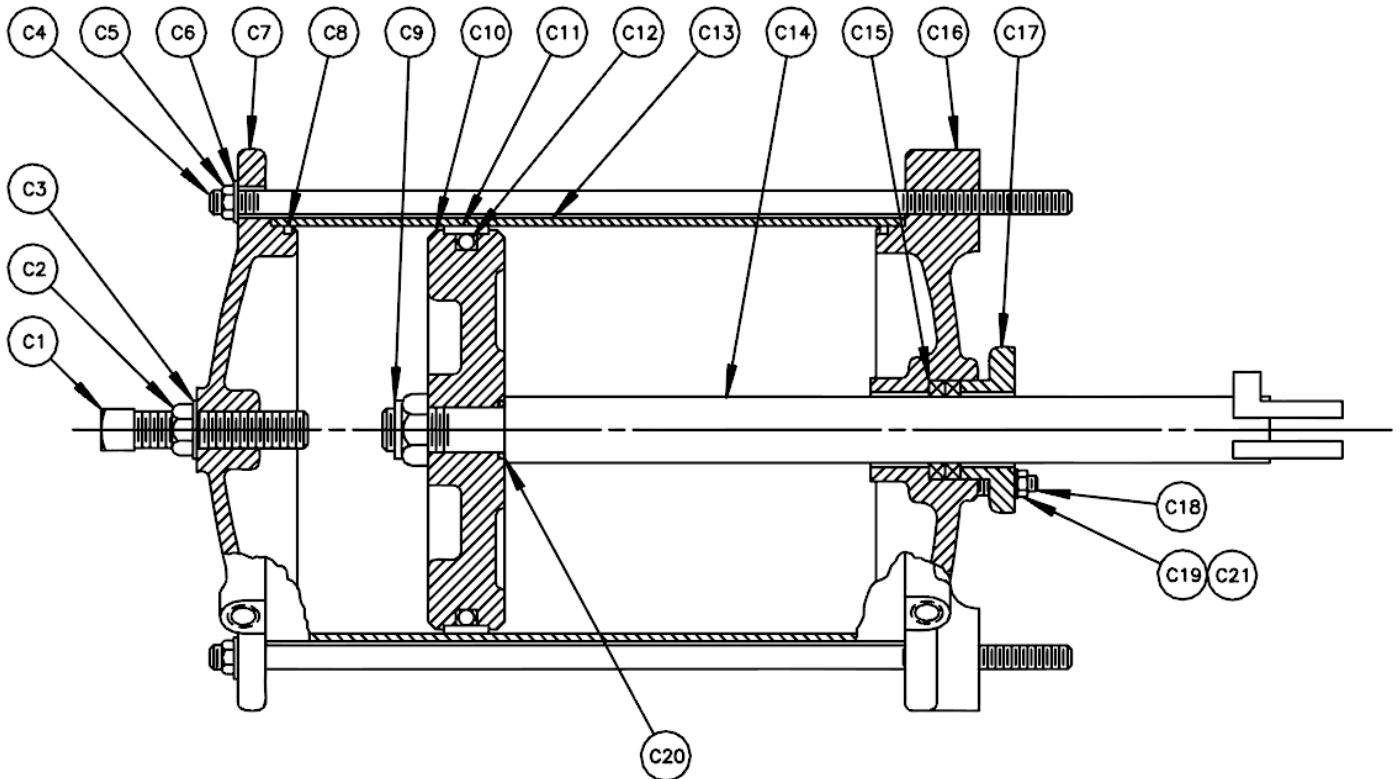

No.	Part Name	Qty.
C1	Set Screw	1
C2	Jam Nut	1
*C3	Thread Seal (Cylinder Cap)	--
C4	Tie Rod (4" & 6" Cylinder)	4
C4	Tie Rod (8" Cylinder)	6
C4	Tie Rod (10" & 12" Cylinder)	8
C5	Nut (4" & 6" Cylinder)	4
C5	Nut (8" Cylinder)	6
C5	Nut (10" & 12" Cylinder)	8
C6	Lock Washer (4" & 6" Cylinder)	4
C6	Lock Washer (8" Cylinder)	6
C6	Lock Washer (10" & 12" Cylinder)	8
C7	Cylinder Cap	1
*C8	O-Ring (Cylinder Tube)	2

No.	Part Name	Qty
C9	Lock Nut	1
C10	Piston	1
*C11	Piston Seal	1
*C12	O-Ring (Piston)	1
C13	Cylinder Tube	1
C14	Piston Rod	1
*C15	Packing Cylinder Head	--
C16	Cylinder Head	1
C17	Gland	1
C18	Stud	2
C19	Jam Nut	2
*C20	O-Ring (Piston Rod)	1
C21	Washer	2

*Items marked by an asterisk included in your repair kit

Figure 1A: Type A Packing Gland Type Cylinder
 The Packing Gland Type Cylinder actuator is identified by the gland (C17).

Type B Cylinder Assembly

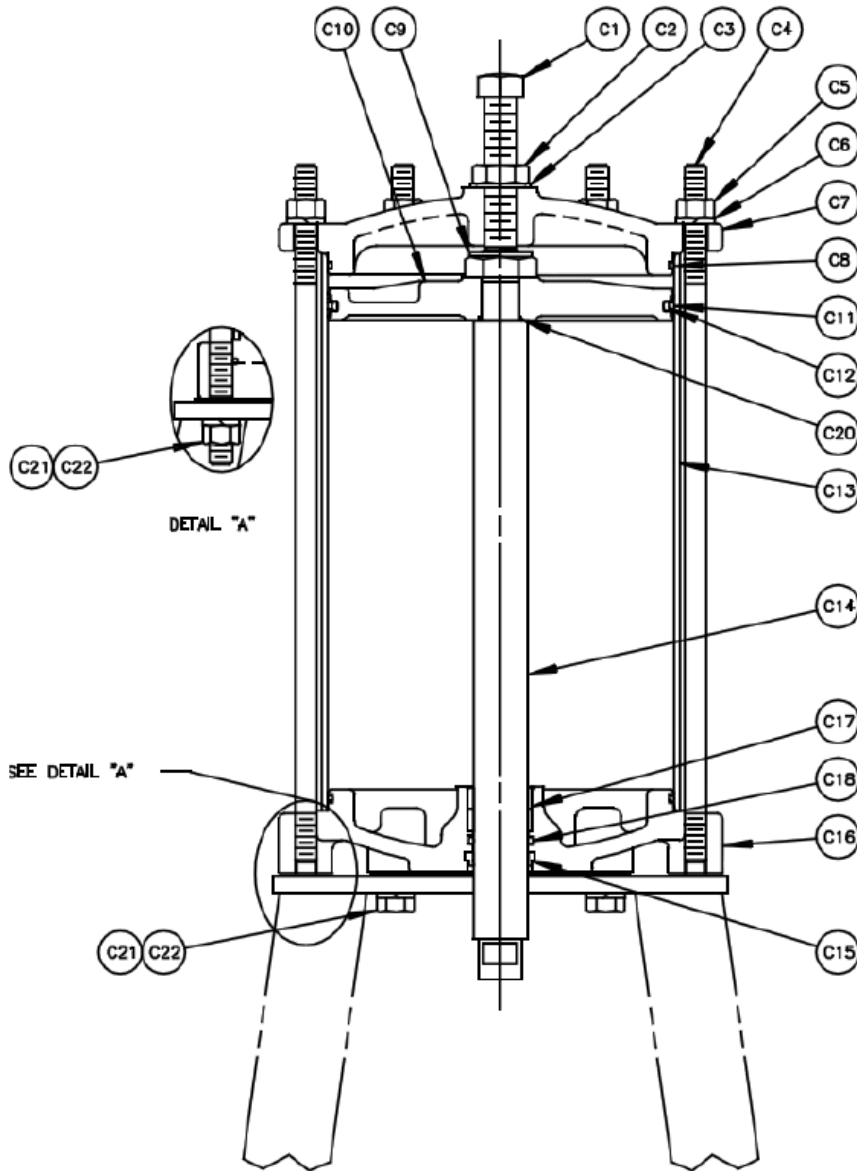

No.	Part Name	Qty.
C1	Set Screw	1
C2	Jam Nut	1
*C3	Thread Seal	1
C4	Tie Rod (6" Cylinder)	4
C4	Tie Rod (10", 12" & 14" Cylinder)	8
C5	Nut (6" Cylinder)	4
C5	Nut (8" Cylinder)	6
C5	Nut (10", 12" & 14" Cylinder)	8
C6	Lock Washer (6" Cylinder)	4
C6	Lock Washer (8" Cylinder)	6
C6	Lock Washer (10", 12" & 14" Cylinder)	8
C7	Cylinder Cap	1
*C8	O-Ring (Cylinder Tube)	2
C9	Lock Nut	1
C10	Piston	1
*C11	Piston Seal	1
*C12	O-Ring (Piston)	1
C13	Cylinder Tube	1
C14	Cylinder Rod	1
*C15	Wiper	1
C16	Cylinder Head	1
C17	Bearing (6", 12", & 14" Cylinders)	1
C17	Bearing (8" & 10" Cylinders)	2
*C18	Rod Seal	1
*C20	O-Ring (Piston Rod)	1
C21	Nut (6" Cylinder)	4
C21	Screw (8-14" Cylinders)	4
C22	Lock Washer	4

*Items marked by an asterisk included in your repair kit

Figure 1B: Type B Cylinder Actuator for UNV and PGV Ported Valves
 Identified by the stepped end of Piston Rod (C14).

Type C Cylinder Assembly

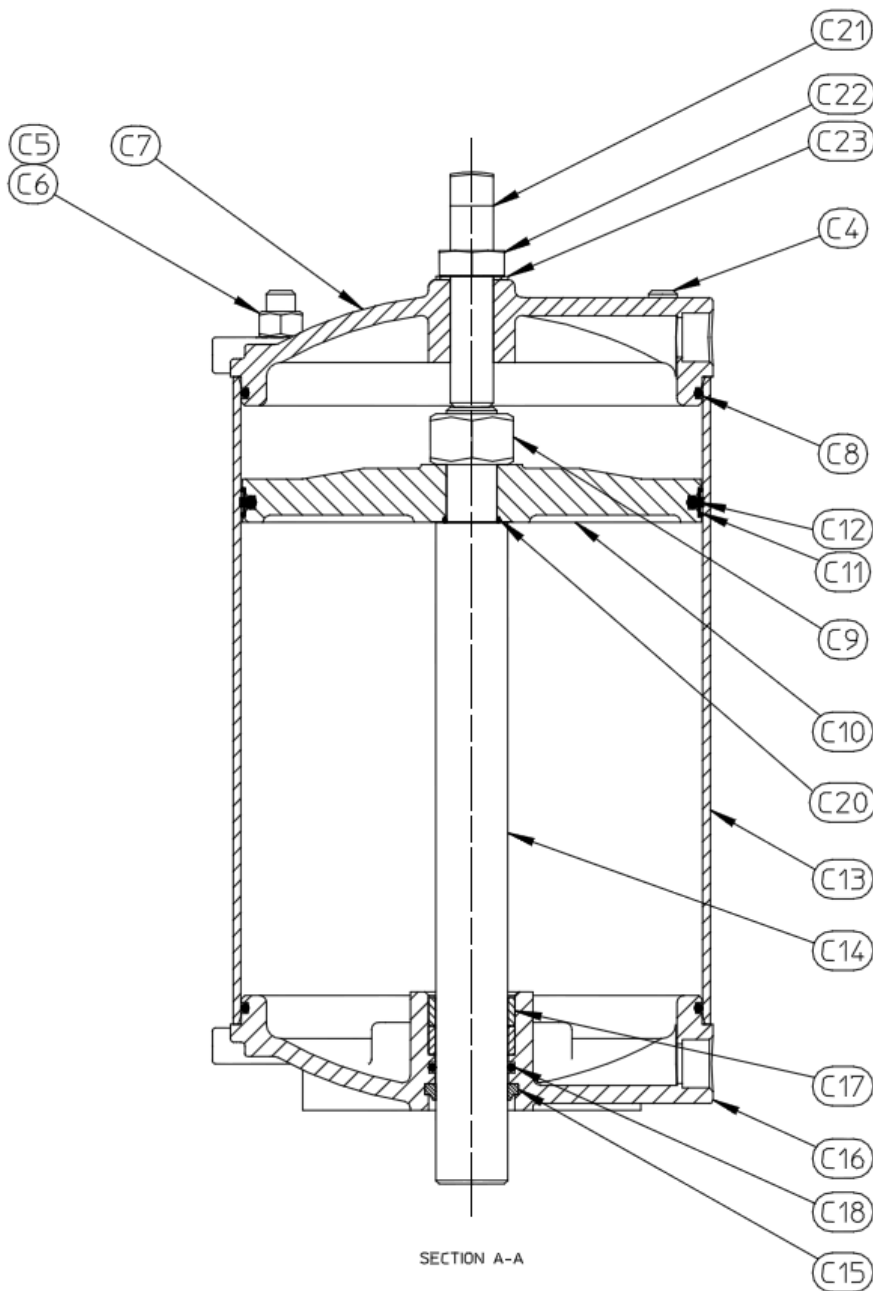

No.	Part Name	Qty.
C4	Tie Rod	4
C5	Nut	4
C6	Lock Washer	4
C7	Cylinder Cap	1
*C8	O-Ring (Cylinder Tube)	2
C9	Lock Nut	1
C10	Piston	1
*C11	Piston Seal (Not Used in Low Temp Cylinder)	1
*C12	O-Ring (Piston)	1
C13	Cylinder Tube	1
C14	Piston Rod	1
*C15	Wiper	1
C16	Cylinder Head	1
C17	Bearing (4", 6", 12", & 14" Cylinders)	1
C17	Bearing (8" & 10" Cylinders)	2
*C18	O-Ring (Cylinder Head)	1
*C20	O-Ring (Piston Rod)	1
C21	Adjusting Screw	1
C22	Jam Nut	1
*C23	Thread Seal	1

*Items marked by an asterisk included in your repair kit

Figure 1C: Type C General Type
Identified by the female thread in the end of the piston rod (C14)

Type D Cylinder Assembly

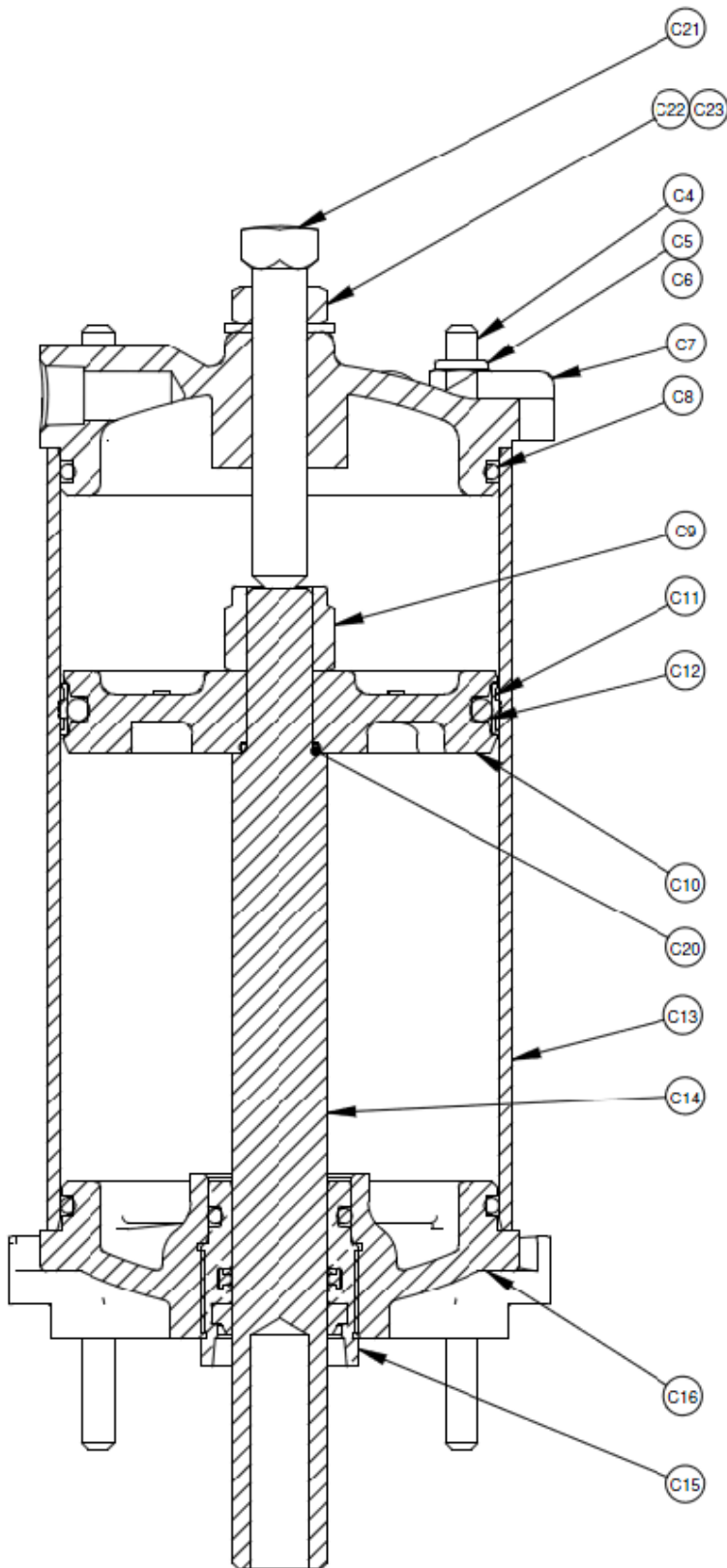

No.	Part Name	Qty.
C4	Tie Rod	4
C5	Nut	4
C6	Lock Washer	4
C7	Cylinder Cap	1
*C8	O-Ring (Cylinder Tube)	2
C9	Lock Nut	1
C10	Piston	1
*C11	Piston Seal (Not Used in Low Temp Cylinder)	1
*C12	O-Ring (Piston)	1
C13	Cylinder Tube	1
C14	Piston Rod	1
C15	Cartridge Assembly	1
C15A	Cartridge	1
*C15B	Wiper	1
*C15C	Rod Seal	1
*C15D	O-Ring	1
C16	Cylinder Head	1
*C20	O-Ring (Piston Rod)	1
C21	Adjusting Screw	1
C22	Jam Nut	1
*C23	Thread Seal	1

*Items marked by an asterisk included in your repair kit

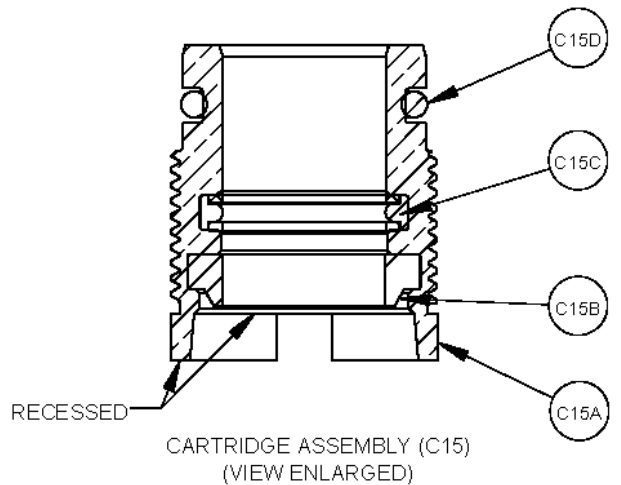
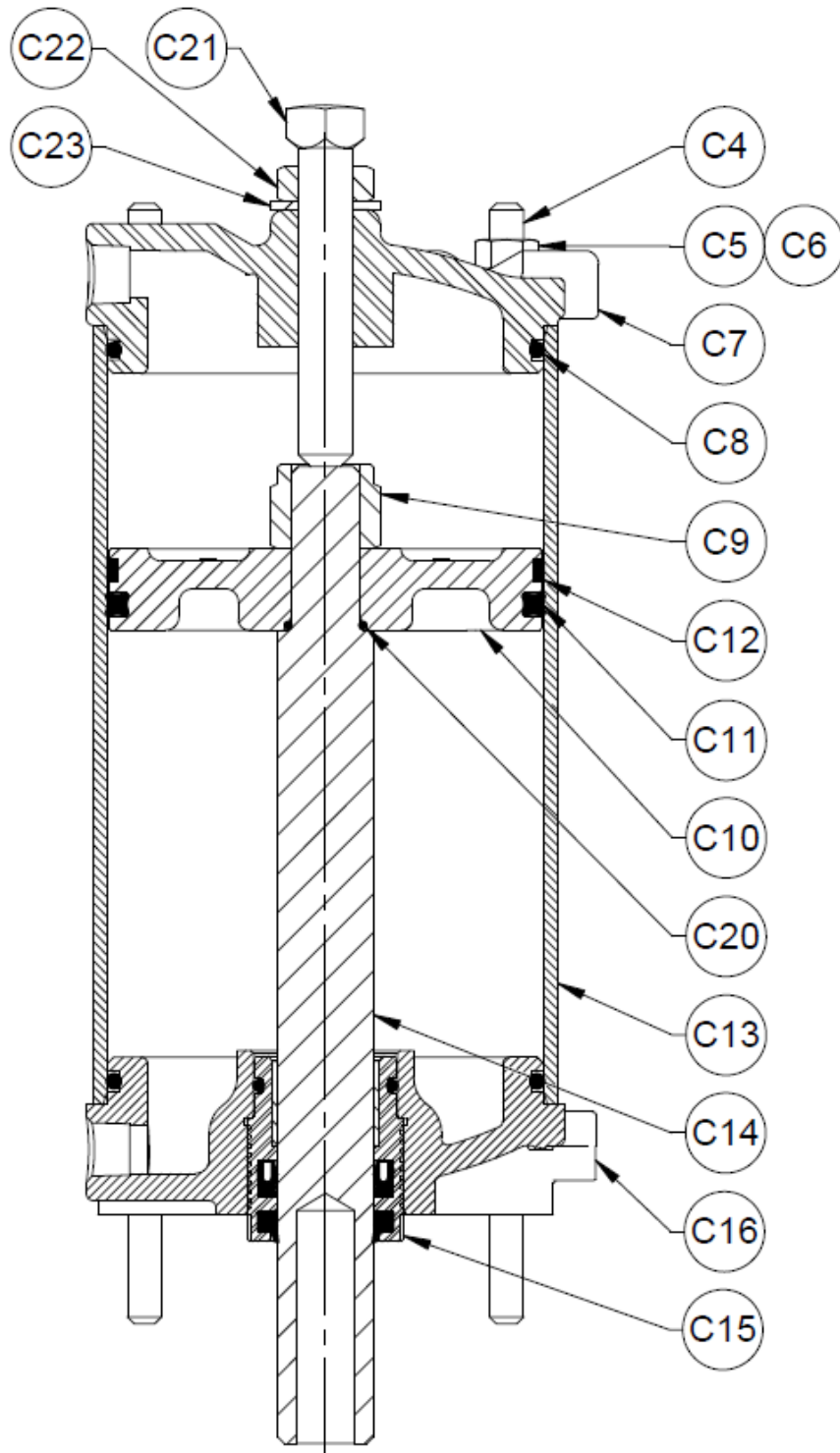

Figure 1D: Type D General Type with Cartridge
 Identified by the recessed Wiper (C15B) in the removable cartridge.

Type E Cylinder Assembly



No.	Part Name	Qty.
C4	Tie Rod	4
C5	Nut	4
C6	Lock Washer	4
C7	Cylinder Cap	1
*C8	O-Ring (Cylinder Tube)	2
C9	Lock Nut	1
C10	Piston	1
*C11	Piston Seal	1
*C12	Piston Wear Ring	1
C13	Cylinder Tube	1
C14	Piston Rod	1
C15	Cartridge Assembly	1
C15A	Cartridge	1
*C15B	Rod Wiper Seal	1
*C15C	Rod U Cup Seal	1
*C15D	Cartridge O-Ring	1
C15E	Bushing	1
C16	Cylinder Head	1
*C20	O-Ring (Piston Rod)	1
C21	Adjusting Screw	1
C22	Jam Nut	1
*C23	Thread Seal	1

*Items marked by an asterisk included in your repair kit

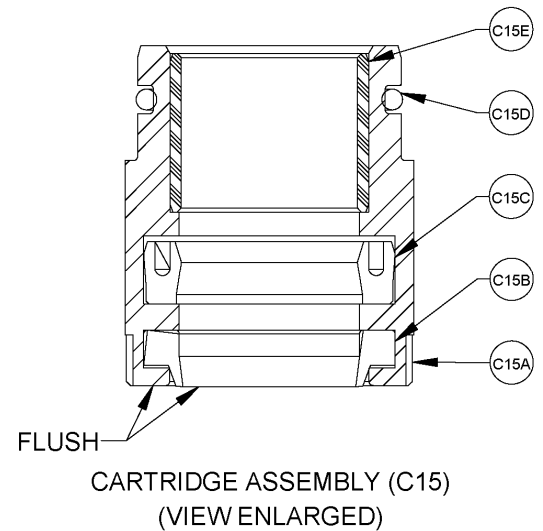

Figure 1E: Type E General Type with Cartridge
Identified by the flush Cup Seal (C15B) in the removable cartridge.

Lubrication

The cylinder only requires lubrication when reassembling a unit that has been disassembled. When reassembling, lubricate the Piston Seal (C11), O-rings (C12), Piston (C10) grooves and inside wall of Cylinder Tube (C13) with Dow Corning No. 44 lubricant, or for cylinders that are for -40°F to -58°F (-40°C to -50°C) environments, lubricate with Dow Corning No. 55 lubricant.

Adjustments

Aligning the Cylinder

To work properly, the Piston Rod (C14) and gate must be aligned. The mounting holes in the cylinder and yoke are designed to allow for adjustment. Visually check the alignment with the valve in the open and close positions, and adjust as needed.

1. Align the Piston Rod (C14) and the gate with each other.
2. Check the Piston Rod (C14) and gate alignment in the valve open and closed positions.
3. Adjust the cylinder position if needed.

Note: Oversized mounting holes in the cylinder and yoke allow for adjustment.

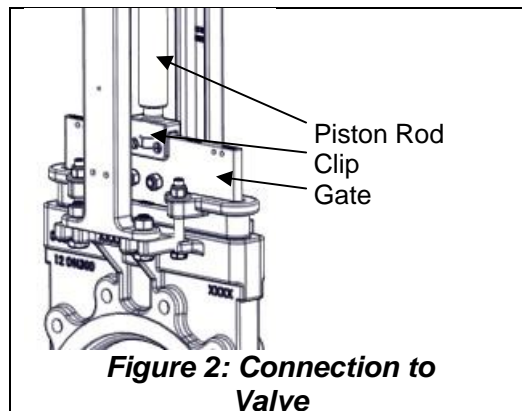

Valve Support

The valve may be mounted in any position around the pipeline, however it is best to mount the valve with the cylinder in a vertical position. If the valve is installed with the cylinder in a position other than vertical, the customer must provide support on valves that are 8 inches and larger. Support can be provided on the outer surfaces of the legs, close to the cylinder. See the installation drawing for dimension location of the support.

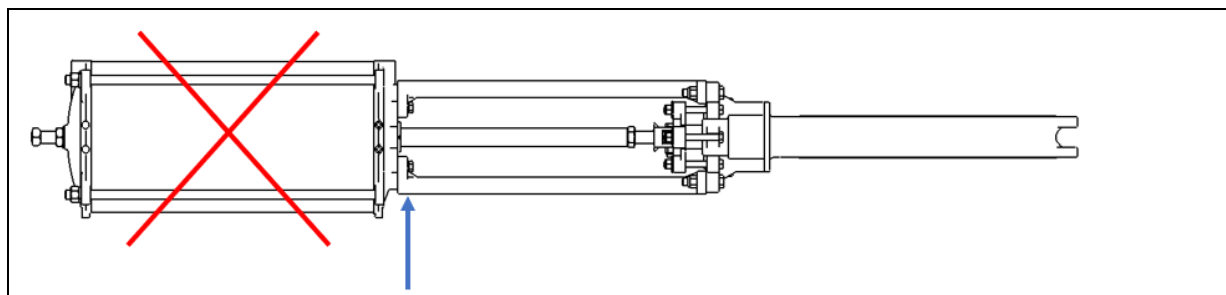

Figure 3: Cylinder Support

NOTICE

Do not mount supports on the Cylinder Tube (C13).

Cylinder Stroke Adjustment (if applicable)

The Adjusting Screw (C1 in Fig. 1A and 1B or C21 in Fig. 1C, 1D and 1E) in the cylinder acts as the cylinder stroke adjustment. Adjust this set screw so that the actuator does not pull the gate off the seat ring when the valve is fully opened.

To adjust the closed position:

1. Close the valve.
2. Turn the clip (see Figure 2) into the piston rod (C14) until the cylinder has a minimum of 1/16" stroke remaining and tighten Jam Nut (C2 in Fig. 1A and 1B or C22 in Fig. 1C, 1D & 1E).
3. Open the valve and adjust the Adjusting Screw (C1 in Fig. 1A and 1B or C21 in Fig. 1C, 1D & 1E) until the gate is clear of the flow port but fully on the seat ring. Tighten Jam Nut (C2 in Fig. 1A and 1B or C22 in Fig. 1C, 1D & 1E).

Piston Rod Packing Adjustment (Fig. 1A)

Type A cylinders which have Packing (C15) around the Piston Rod (C14) which may need periodic adjustment to stop packing leakage. Tighten the Gland Nuts (C19) uniformly only until the leak stops.

IMPORTANT: Once the leak has stopped, do not continue tightening the gland nuts. Over-tightening the gland nuts will result in premature packing failure.

Cartridge Rebuild for Type D Cylinders (Fig. 1D)

To repair a cylinder actuator with the Rod Seal (C15C) and Wiper (C15B) damaged by outside contaminants on the Piston Rod (C14) during the retracting stroke.



WARNING!

This cylinder is a pressure-containing vessel! Removing any parts while under pressure could cause personal injury or equipment damage. Release the pressure from both ends of the cylinder before attempting disassembly or repair.

See Figure 1D. The Rod Seal (C15C) and Wiper (C15B) are installed in the Cartridge (C15A) along with an O-ring (C15D).

Disassembling the cartridge for Type D Cylinders

1. Shut off air supply.
2. Remove the cylinder Cartridge (C15A) by unscrewing it from the Cylinder Head (C16).
3. Slide Cartridge (C15A) all the way down the Piston Rod (C14) and off.
4. Remove the Wiper (C15B), Rod Seal (C15C) and O-ring (C15D) from the Cartridge (C15A).

Reassembling the Cartridge for Type D Cylinders

1. Clean the Cartridge (C15A) grooves and lubricate with Dow Corning Number 44 lubricant or Dow Corning Number 55 in cylinders for -40°F to -58°F (-40°C to -50°C) service
2. Insert the Rod Seal (C15C) into its groove making sure it lies flat in the groove. Insert the PTFE backing rings as shown in Figure 1D. Note that the backing rings are cut with a bevel; make sure the beveled ends of the ring's ends meet but do not overlap.
3. Insert Wiper (C15B) into its groove.
4. Place O-ring (C15D) into its outer groove.
5. Carefully slide Cartridge Assembly (C15), in proper orientation, onto Piston Rod (C14) and screw Cartridge Assembly (C15) into the Cylinder Head (C16).
6. Mount Cylinder on the valve and perform cylinder stroke adjustment as needed.

Cartridge Rebuild for Type E Cylinders (Fig. 1E)

To repair a cylinder actuator with the Rod U Cup Seal (C15C) and Rod Wiper Seal (C15B) damaged by outside contaminants on the Piston Rod (C14) during the retracting stroke.



WARNING!

This cylinder is a pressure-containing vessel! Removing any parts while under pressure could cause personal injury or equipment damage. Release the pressure from both ends of the cylinder before attempting disassembly or repair.

See Figure 1E. The Rod U Cup Seal (C15C) and Rod Wiper Seal (C15B) are installed in the Cartridge Assembly (C15) along with a Cartridge O-ring (C15D).

Disassembling the cartridge for Type E Cylinders

5. Shut off air supply.
6. Remove the Cartridge Assembly (C15) by unscrewing it from the Cylinder Head (C16).
7. Slide Cartridge Assembly (C15) all the way down the Piston Rod (C14) and off.
8. Remove the Rod Wiper Seal (C15B), Rod U Cup Seal (C15C) and Cartridge O-ring (C15D) from the Cartridge (C15A).

Reassembling the Cartridge for Type E Cylinders

7. Clean the Cartridge (C15A) grooves and lubricate with Dow Corning Number 44 lubricant or Dow Corning Number 55 in cylinders for -40°F to -58°F (-40°C to -50°C) service
8. Insert the Rod U Cup Seal (C15C) into its groove making sure it lies flat in the groove.
9. Insert Rod Wiper Seal (C15B) into its groove.
10. Place Cartridge O-ring (C15D) into its outer groove.
11. Carefully slide Cartridge Assembly (C15), in proper orientation, onto Piston Rod (C14) and screw Cartridge Assembly (C15) into the Cylinder Head (C16).
12. Mount Cylinder onto valve and perform cylinder stroke adjustment as needed.

Cartridge Assembly Replacement for Type D & E Cylinders

(Fig. 1D & 1E)



WARNING!

This cylinder is a pressure-containing vessel! Removing any parts while under pressure could cause personal injury or equipment damage. Release the pressure from both ends of the cylinder before attempting disassembly or repair.

1. Shut off air supply.
2. Remove the cylinder Cartridge Assembly (C15) by unscrewing it from the Cylinder Head (C16) with a spanner wrench.
3. Slide Cartridge Assembly (C15) all the way down the Piston Rod (C14) and off.
4. Carefully slide new assembled Cartridge Assembly (C15), in proper orientation, onto Piston Rod (C14) and screw Cartridge Assembly (C15) into the Cylinder Head (C16).
5. Mount Cylinder onto valve and perform cylinder stroke adjustment as needed.

Cylinder Inspection for all Cylinder Types



WARNING!

This cylinder is a pressure-containing vessel! Removing any parts while under pressure could cause personal injury or equipment damage. Release the pressure from both ends of the cylinder before attempting disassembly or repair.

Disassembling the Cylinder

1. Shut off air supply to the cylinder and relieve pipeline and cylinder pressure.
2. Disconnect the air supply lines.
 - a. When flexible tubing is used, only one swivel connector is used on each piece of tubing. The swivel connector is located on the end of the tubing attached to the cylinder port.
3. Remove the Nuts (C5) and Washers (C6) from the Tie-Rods (C4).
4. Remove the Cylinder Cap (C7) and remove the O-ring Seal (C8) from the cylinder Cap (C7).
5. Remove the Cylinder Tube (C13), Piston Seal (C11) and O-ring (C12). Clean the parts and the grooves in the piston (C10).
 - a. Rotating the Cylinder Tube (C13) while pulling makes it easier to get it off the Piston (C10).
6. Remove the Piston Rod (c14) assembly and remove the O-ring (C8) from the Cylinder Head (C16).
 - a. Type A, B, C and D cylinders for -40°F to -58°F (-40°C to -50°C) service applications do not have a piston seal. Type E cylinders will have a piston seal.

Disassembling the Cylinder (continued)

7. Service the Cylinder Head (C16).
 - a. **For Type A:** remove Jam Nut (C19), Washer (C21) and Gland (C17). Pull out Packing (C15) from the Cylinder Head (C16)
 - b. **For Type B:** remove the Wiper (C15) and Rod Seal (C18) from the Cylinder Head (C16). Generally, Bearing(s) (C17) would not normally need to be removed and replaced unless noticeably damaged.
 - c. **For Type C:** remove the Wiper (C15) and Rod Seal (C18) from the Cylinder Head (C16). Generally, Bearing(s) (C17) would not normally need to be removed and replaced unless noticeably damaged.
 - d. **For Type D:** remove Cartridge Assembly (C15). Follow previous instructions on *Cartridge Rebuild for Type D*.
 - e. **For Type E:** remove Cartridge Assembly (C15). Follow previous instructions on *Cartridge Rebuild for Type E*.
8. Clean all parts thoroughly. Replace damaged parts.

Assembling the Cylinder

1. Clean bore of Cylinder Head (C16) and lubricate with Dow Corning Number 44 lubricant, or Dow Corning Number 55 on cylinders used in -40°F to -58°F (-40°C to -50°C) service.
2. Lubricate the O-ring (C8) and place it on the Cylinder Head (C16).
3. Install Cylinder Head (C16) seals:
 - a. **For Type A cylinders:** Packing layers (C15) will be installed and adjusted as final step.
 - b. **For Type B and C cylinders:** Lubricate and install the Piston Rod Seal (C18) and Wiper (C15) in the Cylinder Head (C16). Insert the PTFE backing rings as shown in Figure 4. The backing rings are cut with a bevel. Make sure the beveled ends of the rings meet but do not overlap. If Bearings (C17) were removed, install those now.
 - a. **For Type D and E cylinders:** Clean and thread the cylinder Cartridge Assembly (C15) into the Cylinder Head (C16)



Figure 4: PTFE Backing Rings

4. Carefully install the Piston Rod (C14).
5. Lubricate the Piston Seal (C11), O-ring (C12) and cylinder groove. Place O-ring (C12) and Seal (C11) on the Piston (C10). On Type A, B, C & D cylinders in cold service applications, -40°F to -58°F (-40°C to -50°C), a Piston Seal (C11) is not used. Dow Corning No. 55 lubricant should be applied in these situations.
6. Slide the Cylinder Tube (C13) over the Piston (C10). The Piston Seal (C11) must be well lubricated. Start the Cylinder Tube (C13) at a 45° angle and rotate it into position onto the Piston (C10). See Figure 5.
7. Lubricate the O-ring (C8) and place it on the Cylinder Cap (C7).
8. Place the Cylinder Cap (C7) on the Cylinder Tube (C13) and place the Washers (C6) and Nuts (C5) on the Tie Rods (C4). Tighten the Nuts (C5) to the torque listed in Table A.
9. For Type A Cylinders: insert Packing Layers (C15) around the Piston rod (C14). Install the Gland (C17), Washers (C21) and Nuts (C19). Lightly tighten the Gland Nuts (C19) until they are just snug. Apply Air pressure to the port in the Packing Cylinder Head (C15). Tighten the Gland Nuts (C19) uniformly only until any leak stops.

Table A: Tie Rod Nut Torques

Cylinder Size	Torque	
	Lbs. Ft.	Nm
C4	12	16
C6-C8	16	22
C10-C14	20	27

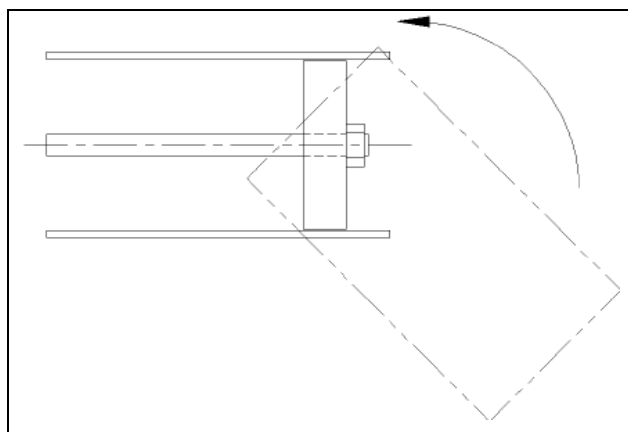

Figure 5: Assembling Cylinder

Troubleshooting

<i>Condition</i>		<i>Possible Cause</i>	<i>Corrective Action</i>
External Leakage	Cartridge leak	Worn or damaged piston rod or cartridge	Replace piston rod if surface is rough Replace piston rod and rebuild or replace cartridge if worn
		Cylinder tube seal leak	Loose tie rods
	Excessive pressure		Reduce pressure below maximum pressure of 100 psi
	Damaged O-rings	Replace O-rings and torque tie rod nuts. See Table A	
Internal Leakage	Piston seal leakage	Piston seal wear	Replace seal O-ring as required
		Cylinder drifts	Pressurize one side of the cylinder piston and disconnect air/fluid line at opposite port. If no leakage, find cause of cylinder drift in other component parts in the circuit
Cylinder Fails to Move the Load	Pressure is too low		Check pressure at cylinder, make sure it is to circuit requirements
	Piston seal leakage		Cycle cylinder by operating the valve, watch air flow at valve exhaust ports at end of cylinder stroke. Replace piston seals if flow is excessive.
	Cylinder is undersized for the load		Replace cylinder with one of a larger bore size
	Piston rod broken		Contact your local DeZURIK representative to order new piston rod
Erratic or Chatter Operation	Load misalignment, excessive friction at cartridge or piston		Correct alignment of cylinder to load
	Load requirements are too closely sized to cylinder		Install larger cylinder
	Static and kinetic friction		Install speed control valves to provide back pressure for controlling stroke

Limited Warranty

DeZURIK, Inc. ("Seller") manufactured products, auxiliaries and parts thereof that we manufacture for a period of twenty-four (24) months from date of shipment from Seller's factory, are warranted to the original purchaser only against defective workmanship and material, but only if properly stored, installed, operated, and serviced in accordance with Seller's recommendations and instructions.

For items proven to be defective within the warranty period, your exclusive remedy under this limited warranty is repair or replacement of the defective item, at Seller's option, FCA Incoterms 2020 Seller's facility with removal, transportation, and installation at your cost.

Products or parts manufactured by others but furnished by Seller are not covered by this limited warranty. Seller may provide repair or replacement for other's products or parts only to the extent provided in and honored by the original manufacturer's warranty to Seller, in each case subject to the limitations contained in the original manufacturer's warranty.

No claim for transportation, labor, or special or consequential damages or any other loss, cost or damage is being provided in this limited warranty. You shall be solely responsible for determining suitability for use and in no event shall Seller be liable in this respect.

This limited warranty does not warrant that any Seller product or part is resistant to corrosion, erosion, abrasion or other sources of failure, nor does Seller warrant a minimum length of service.

Your failure to give written notice to us of any alleged defect under this warranty within twenty (20) days of its discovery, or attempts by someone other than Seller or its authorized representatives to remedy the alleged defects therein, or failure to return product or parts for repair or replacement as herein provided, or failure to store, install, or operate said products and parts according to the recommendations and instructions furnished by Seller shall be a waiver by you of all rights under this limited warranty.

This limited warranty is voided by any misuse, modification, abuse or alteration of Seller's product or part, accident, fire, flood or other Act of God, or your failure to pay entire contract price when due.

The foregoing limited warranty shall be null and void if, after shipment from our factory, the item is modified in any way or a component of another manufacturer, such as but not limited to; an actuator is attached to the item by anyone other than a Seller factory authorized service personnel.

All orders accepted shall be deemed accepted subject to this limited warranty, which shall be exclusive of any other or previous warranty, and this shall be the only effective guarantee or warranty binding on Seller, despite anything to the contrary contained in the purchase order or represented by any agent or employee of Seller in writing or otherwise, notwithstanding, including but not limited to implied warranties.

THE FOREGOING REPAIR AND REPLACEMENT LIMITED WARRANTY IS IN LIEU OF ALL OTHER WARRANTIES, OBLIGATIONS AND LIABILITIES, INCLUDING, BUT NOT LIMITED TO, ALL WARRANTIES OF FITNESS FOR A PARTICULAR PURPOSE OR OF MERCHANTABILITY OR OTHERWISE, EXPRESSED OR IMPLIED IN FACT OR BY LAW, AND STATE SELLER'S ENTIRE AND EXCLUSIVE LIABILITY AND YOUR EXCLUSIVE REMEDY FOR ANY CLAIM IN CONNECTION WITH THE SALE AND FURNISHING OF SERVICES, GOODS OR PARTS, THEIR DESIGN, SUITABILITY FOR USE, INSTALLATION OR OPERATIONS. NEITHER ANY PERFORMANCE OR OTHER CONDUCT, NOR ANY ORAL OR WRITTEN INFORMATION, STATEMENT, OR ADVICE PREPARED BY SELLER OR ANY OF OUR EMPLOYEES OR AGENTS WILL CREATE A WARRANTY, OR IN ANY WAY INCREASE THE SCOPE OR DURATION OF THE LIMITED WARRANTY.

Disclaimer

Metric fasteners should not be used with ASME Class 150/300 bolt holes and flange bolt patterns. If you use metric fasteners with ASME Class 150/300 bolt holes and flange bolt patterns, it may lead to product failure, injury, and loss of life. DeZURIK Inc. disclaims all liability associated with the use of metric fasteners with ASME Class 150/300 bolt holes and flange patterns, including but not limited to personal injury, loss of life, loss of product, production time, equipment, property damage, lost profits, consequential damages of any kind and environment damage and/or cleanup. Use of metric fasteners with ASME Class 150/300 bolt holes and flange bolt patterns is a misuse that voids all warranties and contractual assurances. If you use metric fasteners with ASME Class 150/300 bolt holes and flange bolt patterns, you do so at your sole risk and any liability associated with such use shall not be the responsibility of DeZURIK, Inc. In addition to the foregoing, DeZURIK's Manufacturer's Conditions apply.

Limitation of Liability

IN NO EVENT SHALL SELLER BE LIABLE FOR ANY DIRECT, INDIRECT, SPECIAL, PUNITIVE, EXEMPLARY, OR CONSEQUENTIAL DAMAGES (INCLUDING, BUT NOT LIMITED TO; DAMAGE TO OR LOSS OF OTHER PROPERTY OR EQUIPMENT, BUSINESS INTERRUPTION, COST OF SUBSTITUTE PRODUCTS, LOSS OF TIME, LOSS OF PROFITS OR REVENUE, COST OF CAPITAL, LOSS OF USE, OR DIMINUTION IN VALUE) WHATSOEVER, AND SELLER'S LIABILITY, UNDER NO CIRCUMSTANCES, WILL EXCEED THE CONTRACT PRICE FOR THE GOODS AND/OR SERVICES FOR WHICH LIABILITY IS CLAIMED. ANY ACTION FOR BREACH OF CONTRACT BY YOU, OTHER THAN RIGHTS RESPECTING OUR LIMITED WARRANTY DESCRIBED ABOVE, MUST BE COMMENCED WITHIN 12 MONTHS AFTER THE DATE OF SALE.



Need Knife Gate Valve pricing or support for your mining project? Contact us for more assistance.

Perth Branch
U2/41-45 Furnace Road
Welshpool WA 6106
Phone: +61 8 9353 2565
sales@thevalvecompany.com.au

Kalgoorlie Branch
2/69 Craig Road
West Kalgoorlie WA 6430
Phone: +61 8 9021 6668
sales@thevalvecompany.com.au

Brisbane Branch
U5/225 Queensport Road
North Murrarie QLD 4172
Phone: +61 7 3348 8636
sales@thevalvecompany.com.au

Bunbury Branch
Phone: +61 417 744 791
sales@thevalvecompany.com.au