

# KGC-MD Knife Gate Valves

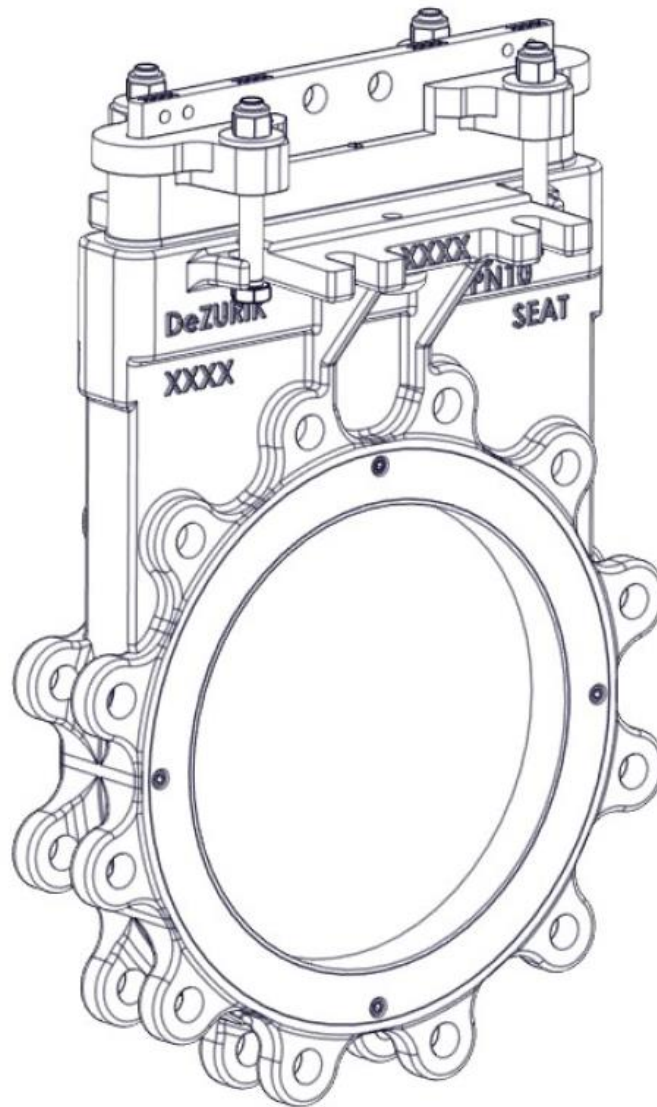

Instruction **D11032**  
July 2018

## Instructions

These instructions are for use by personnel who are responsible for the installation, operation and maintenance of DeZURIK valves, actuators or accessories.

## Safety Messages

All safety messages in the instructions are identified by a general warning sign and the signal word CAUTION, WARNING or DANGER. These messages indicate procedures to avoid injury or death.

Safety label(s) on the product indicate hazards that can cause injury or death. If a safety label becomes difficult to see or read, or if a label has been removed, please contact DeZURIK for replacement label(s).

---

### **⚠WARNING**

**Personnel involved in the installation or maintenance of valves should be constantly alert to potential emission of pipeline material and take appropriate safety precautions. Always wear suitable protection when dealing with hazardous pipeline materials. Handle valves which have been removed from service with suitable protection for any potential pipeline material in the valve.**

---

## Inspection

Your DeZURIK product has been packaged to provide protection during shipment; however, items can be damaged in transport. Carefully inspect the unit for damage upon arrival and file a claim with the carrier if damage is apparent.

## Parts

Replaceable wear parts are listed on the assembly drawing. These parts can be stocked to minimize downtime. Order parts from your local DeZURIK sales representative or directly from DeZURIK. When ordering parts please provide the following information:

**If the valve has a data plate:** please include the 7-digit part number with either 4-digit revision number (example: 9999999R000) or 8-digit serial number (example: S1900001) whichever is applicable. The data plate will be attached to the valve assembly. Also, include the part name, the assembly drawing number, the balloon number and the quantity stated on the assembly drawing.

**If there isn't any data plate visible on the valve:** please include valve model number, part name, and item number from the assembly drawing. You may contact your local DeZURIK Representative to help you identify your valve.

## DeZURIK Service

DeZURIK service personnel are available to maintain and repair all DeZURIK products. DeZURIK also offers customized training programs and consultation services. For more information, contact your local DeZURIK sales representative or visit our website at [DeZURIK.com](http://DeZURIK.com).

## **Table of Contents**

Description	4
Handling	4
Installation	6
Operation	7
Lubrication	7
Packing	7
Adjustment	7
Drawings	8
Packing Replacement	9
<i>Removing the Old Packing</i>	9
<i>Installing the New Packing</i>	0
<i>Reassembling the Valve</i>	11
Seat Replacement	11
<i>Reassembling the Valve</i>	11
Replacing the Gate	12
Replacing the Clip	13
Purge Port Option	14
Troubleshooting	16

---

# DeZURIK

## KGC-MD KNIFE GATE VALVES

### Description

KGC-MD knife gate valves have a stainless steel body and gate, and an all-metal or metal/resilient seat. The KGC-MD knife gate valve is available in 3-24" sizes. A choice of several actuators and accessories is available.

### Handling



#### WARNING!

A potential hazard exists with handling valves. Failure to handle valves properly may cause a valve to shift, slip or fall causing serious injury or death and/or equipment damage.

*The points below are for reference purposes only, use safe and proper lifting and support techniques. DO NOT lift valves with any adjoining pipe or other equipment attached. Lift with properly rated lifting equipment. Follow jurisdictional safety requirements.*

Suggested lifting points are as shown below to lift valve assemblies that are in a horizontal orientation. Eye bolts in flange through holes can be used to lift the valve body or, for 2" through 12" valves, a sling can be strapped around the top of the valve body.

For valves with bevel gear actuators, a sling or chain can be wrapped around the bevel gear actuator body, between the mounting plate and the input shaft housing. This would be in conjunction with lifting from the valve body as well. See Figure 1.

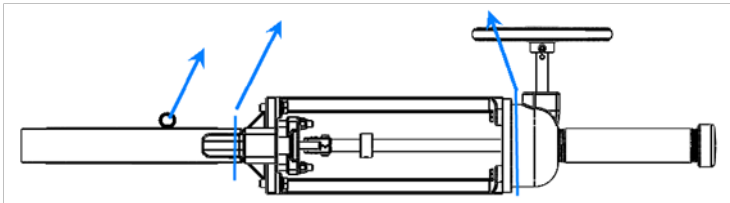

**Figure 1— Knife Gate Valve with Bevel Gear Actuator, Horizontal Lifting**

For valves with pneumatic cylinder actuators, a sling can be wrapped around the cylinder, near the cylinder head (piston rod end). This would be in conjunction with lifting from the valve body. Utilize caution to not bump, dent or damage the cylinder tube. DO NOT utilize the cylinder tie-rod ends to lift. See Figure 2.

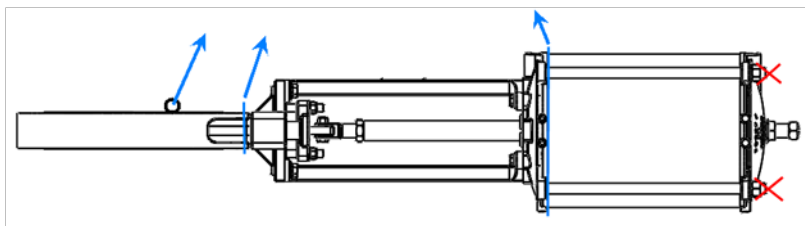

**Figure 2, Knife Gate Valve with Pneumatic Cylinder Actuator, Horizontal Lifting**

**Handling *continued***

For valves with handwheel actuators, a sling or chain can be wrapped through the rim of the handwheel. For chainwheel actuators, a sling can be wrapped in the area between the yoke/legs and the chainwheel/guide assembly. This would be in conjunction with lifting from the valve body as well. See Figure 3.

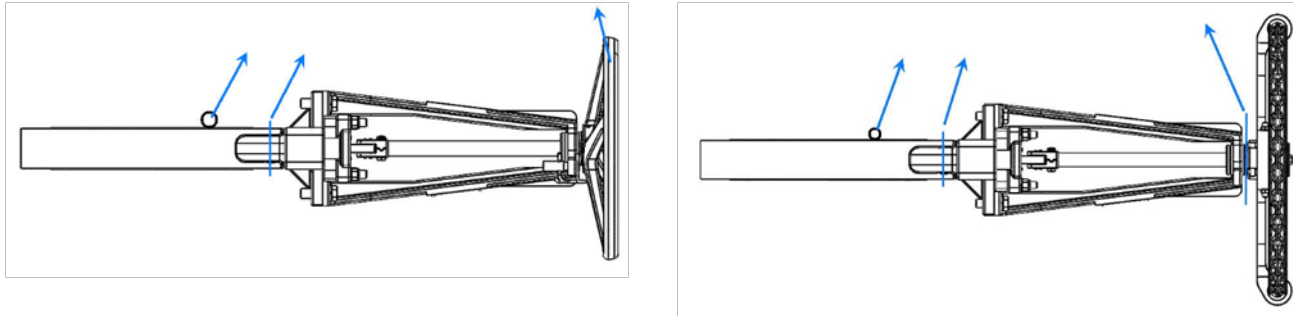
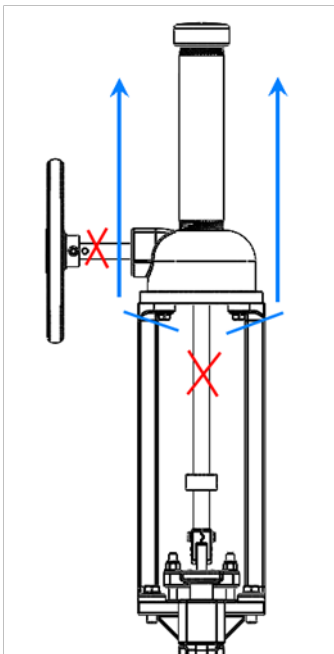

**Figure 3, Knife Gate Valve with Handwheel or Chainwheel Actuator, Horizontal Lifting**

Suggested lifting options are as shown below to lift valve assemblies that are in a vertical orientation. For valves with bevel gear actuators, wrap slings or chains around the top of each leg. Use caution not to put any side load on the bevel gear input shaft or on the valve's threaded stem. See Figure 4.

For valves with pneumatic cylinder actuators, wrap slings around the top of each leg. Use caution to not bump, dent or damage the cylinder tube and avoid any side load on the cylinder piston rod. DO NOT utilize the cylinder tie-rod ends to lift. See Figure 5.

For valves with handwheel or chainwheel actuators, wrap slings or chains around the top of the each leg or yoke side. Use caution to not put any side load on the valve's threaded stem. See Figure 6.



**Figure 4- Knife Gate Valve with Bevel Gear Actuator, Vertical Lifting**

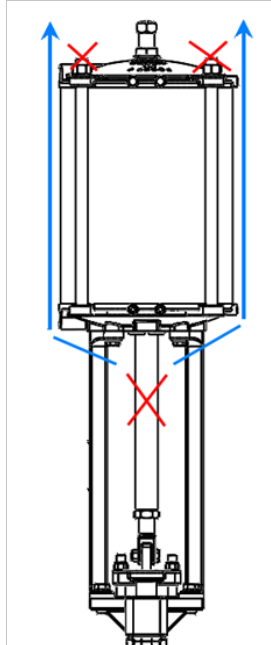

**Figure 5- Knife Gate Valve with Pneumatic Cylinder Actuator, Vertical Lifting**

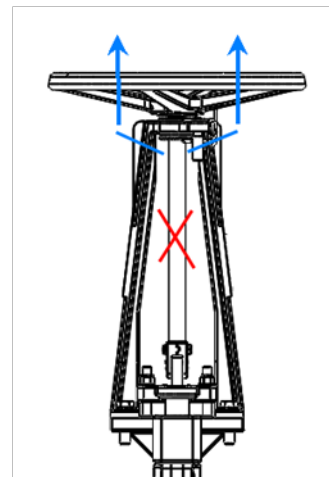

**Figure 6- Knife Gate Valve with Handwheel or Chainwheel Actuator, Vertical Lifting**

## Installation

Install the valve between ANSI Class 125 or Class 150 pipeline flanges, or other flanges that match valve end connection. Flange gaskets are required. Before installation, remove foreign material such as weld spatter, oil, grease, and dirt from the valve and pipeline.

### Cyclone or Gravity (Dry) Service Installations

When installing the valve in a vertical pipeline (such as a cyclone hopper bottom, gravity flow, or other dry service application), install the “SEAT” side of the valve facing upstream as shown in Figure 1. Installing the valves with the seat side upstream prevents process media buildup in the seat and chest area of the valve. This orientation also allows the seat to act as an integral deflection cone, protecting the seat from wear.

### Other Installations

Install the valve so that the side marked “SEAT” is on the lower pressure side of the valve when the valve is closed; the pipeline pressure will then help seal the valve in the closed position.

### General Guidelines

Observe the following points to prevent distortion of the valve body and gate when the flange bolts are tightened:

- Align the mating pipeline flanges.
- Select the length of the flange bolts so that the bolts used in the blind holes near the chest area of the valve do not bottom out when tightened. We recommend using studs with nuts in the blind holes.
- Tighten the flange bolts evenly, in a crisscross pattern. Refer to Table A for recommended flange bolt/stud torques.

**Note:** Torque ranges are based on ASME Pressure Vessel Code Calculations and lab test data. These torques are only for the listed gasket types. For other gasket types listed in ASME, consult DeZURIK.

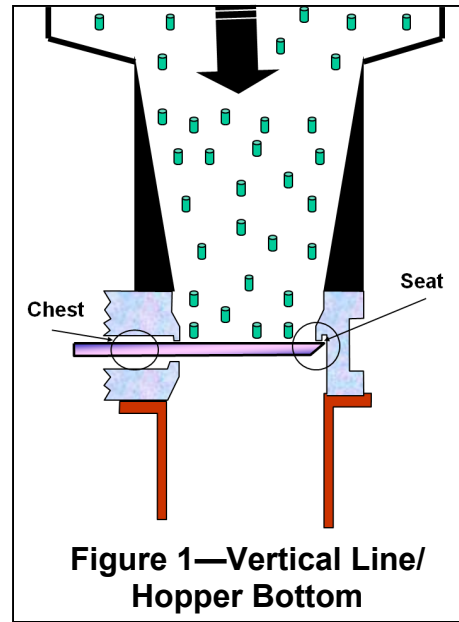

**Table A: Recommended Flange Bolt/ Stud Torque Range in ft-lbs (non-lubricated)**

Valve Size	ASME Gasket Types	
	Rubber with Soft Fabric Filler and 1/8" Thick Hard	Soft Elastomer Gasket Shore Durometer <75A
<u>in.</u> <u>mm.</u>	<u>ft.lbs.</u> <u>Nm</u>	<u>ft.lbs.</u> <u>Nm</u>
<u>3"</u> 75mm	<u>26 - 29</u> 35 - 39	<u>11 - 12</u> 15 - 16
<u>4"</u> 100mm	<u>36 - 40</u> 49 - 54	<u>17 - 19</u> 23 - 26
<u>6"</u> 150mm	<u>41 - 45</u> 56 - 61	<u>22 - 24</u> 30 - 33
<u>8"</u> 200mm	<u>55 - 61</u> 75 - 83	<u>35 - 39</u> 47 - 53
<u>10"</u> 250mm	<u>56 - 62</u> 76 - 84	<u>40 - 44</u> 54 - 60
<u>12"</u> 300mm	<u>80 - 88</u> 108 - 119	<u>59 - 65</u> 80 - 88
<u>14"</u> 350mm	<u>107 - 118</u> 145 - 160	<u>81 - 89</u> 110 - 121
<u>16"</u> 400mm	<u>103 - 114</u> 140 - 155	<u>79 - 87</u> 107 - 118
<u>18"</u> 450mm	<u>128 - 141</u> 174 - 191	<u>102 - 112</u> 138 - 152
<u>20"</u> 500mm	<u>123 - 136</u> 167 - 184	<u>99 - 109</u> 134 - 148
<u>24"</u> 600mm	<u>188 - 207</u> 255 - 281	<u>155 - 171</u> 210 - 232

## **Installation continued**

**Note:** The packing gland is slightly loosened prior to shipping. This is done to increase the life of the packing during extended storage.

After installing the valve, pressurize pipeline and ensure the packing is not leaking. If the packing leaks, adjust the packing as described below.

## **Operation**

The gate in the valve is positioned by the valve actuator. The actuator moves the gate over the valve port in the closed position, and withdraws the gate from the port in the open position. Refer to the Actuator Instructions for adjustment and maintenance requirements for the actuator.

## **Lubrication**

The valve does not require lubrication. If applicable, ensure that valve threaded stems are maintained with proper lubrication. Refer to the Actuator Instructions for lubrication requirements for the actuator.

## **Packing**

The gate packing is contained and compressed by the packing gland. See Figure 2 for component identification.

## **Adjustment**

If packing leaks, tighten the adjustment nuts on top of the packing gland. Tighten the nuts equally and gently just enough to stop the leak. Over tightening will cause excessive operating forces, and will decrease the life of the packing.

**DeZURIK**  
**3-24" KGC-MD KNIFE GATE VALVES**

**Drawings**

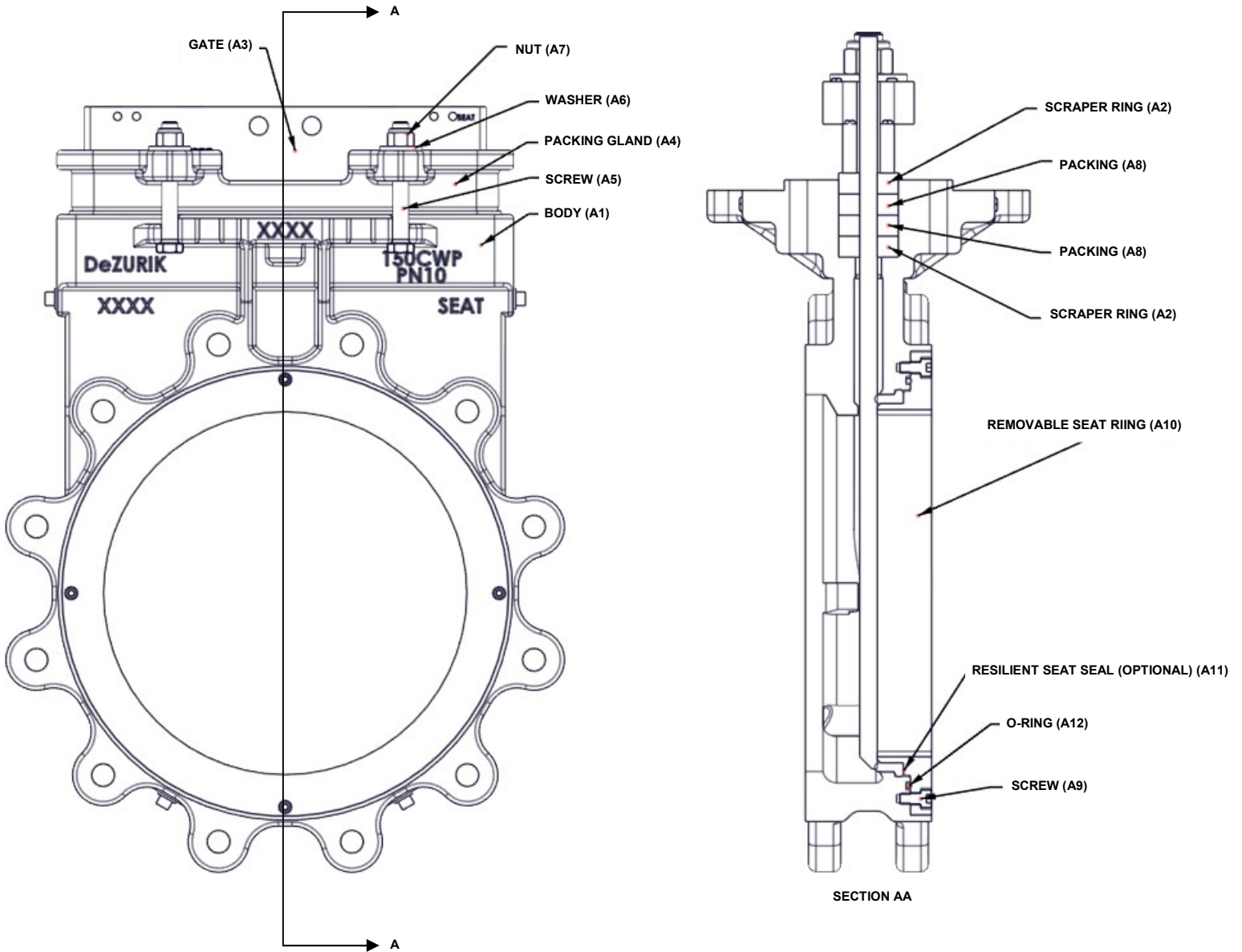

**Figure 2—Component Identification**



## **Packing Replacement**

### *Removing the Old Packing*

---



**WARNING!**

Pipeline pressure can cause personal injury or equipment damage. Relieve pipeline pressure before removing gate stem and packing gland nuts.

---

1. Relieve the pressure in the pipeline and close the valve.
- 



**WARNING!**

Accidental operation of power actuator can cause personal injury or equipment damage. Disconnect and lock out power to actuator before servicing.

---

2. If the actuator is powered, disconnect and lock out power to prevent accidental operation of the actuator.
3. Remove the two screws and nuts near the top of the gate and disengage the stem from the gate by stroking the actuator (not the valve) to the open position.
4. Remove the gland nuts (A7), screws (A5) and packing gland (A4).
5. Remove the used scraper rings (A2) and packing (A8) from the packing chamber.

# DeZURIK

## KGC-MD KNIFE GATE VALVES

### Installing the New Packing

Scraper ring (A2) and packing (A8) ring length and quantity are shown in Table B. DeZURIK provides extra packing in their packing kits, but do not try to put more packing into a layer than shown in Table B. If packing for low pressure applications (<40psi [2.7 bar]), contact DeZURIK.

1. Ensure the gate (A3) is fully closed and centered in the body before packing.
2. Assemble and pack the rings one at a time, with the ends together, but not overlapped. Ensure the inside and outside edges of each ring are packed against the gate and packing chamber, so that each ring is compressed flat and evenly.

**Note:** Stagger the joints, on the long side of the packing chamber. To pack the rings, we recommend using a square-ended wood or plastic tool, driven by a hammer or mallet. Do not use a sharp tool to pack the rings.

- a. Place (A2) scraper ring in the bottom of the packing chamber.
- b. Assemble and pack two rows of packing (A8).
- c. Assemble and pack the last row of scraper ring (A2). See Figure 3:

**Table B: Packing Ring and Scraper Rings Length and Quantity**

Valve Size <u>in.</u> mm.	Square Size <u>in.</u> mm.	Length <u>in.</u> mm.	No. of Scraper Rings	No. of Packing Rings
<u>3"</u> 75mm	<u>0.375</u> 9.5	<u>11.50</u> 293	2	2
<u>4"</u> 100mm		<u>13.50</u> 343		
<u>6"</u> 150mm		<u>15.50</u> 394		
<u>8"</u> 200mm		<u>20.00</u> 508		
<u>10"</u> 250mm	<u>0.500</u> 12.7	<u>25.00</u> 635		
<u>12"</u> 300mm		<u>29.00</u> 737		
<u>14"</u> 350mm		<u>32.00</u> 813		
<u>16"</u> 400mm		<u>36.75</u> 934		
<u>18"</u> 450mm	<u>0.625</u> 15.9	<u>41.25</u> 1048		
<u>20"</u> 500mm		<u>45.25</u> 1150		
<u>24"</u> 600mm		<u>53.50</u> 1359		

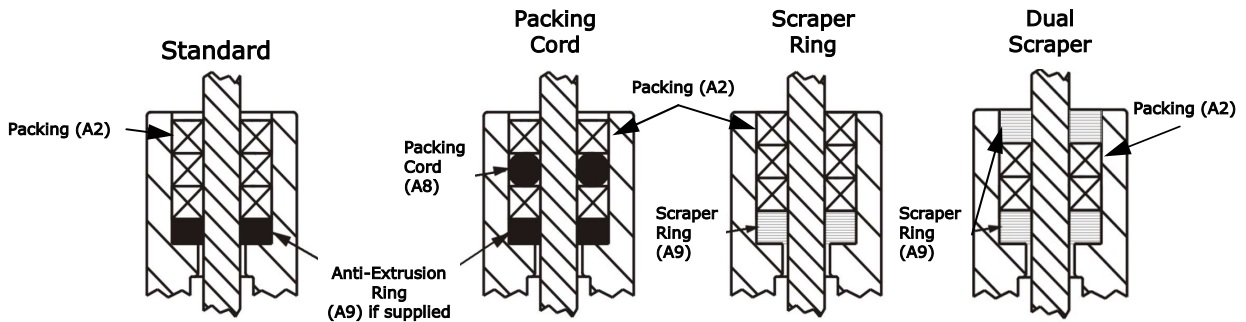

**Figure 3—Packing Detail**

For all packing types, push excess packing toward the side opposite the seat.

### **Reassembling Valve**

1. Replace the packing gland (A4), screws (A5), washer (A6) and nuts (A7). Tighten the nuts evenly and finger tight, plus 1/2 turn.
2. Reconnect the stem to the gate with the two screws and nuts.
3. If the actuator is a powered actuator, reconnect power to the actuator.
4. Pressurize the pipeline and inspect packing for leakage.
5. If packing leaks, tighten the adjustment nuts (A7) on top of the packing gland. Tighten the nuts evenly and gently - just enough to stop the leak. Over tightening will cause excessive operating forces, and will decrease the life of the packing.

### **Replacing the Seat**

See Figure 4 for component identification.



**WARNING!**

**Pipeline pressure can cause personal injury or equipment damage. Relieve pipeline pressure before removing gate stem and packing gland nuts.**

---

1. Relieve the pressure in the pipeline and close the valve.



**WARNING!**

**Accidental operation of power actuator can cause personal injury or equipment damage. Disconnect and lock out power to actuator before servicing.**

---

2. If the actuator is powered, disconnect and lock out power to prevent accidental operation of the actuator.
3. Remove the pipeline flange bolts and pipe from the side of the valve body marked "SEAT". As an alternative, remove both flanges, and remove the valve from the pipeline.
4. Remove (4) screws (A9) that holds removable seat in place.
5. Remove the removable seat (A10) from the body and resilient seat seal (A11) if supplied.
6. Remove the o-ring (A12).
7. Install the new removable seat:
  - a. Coat the o-ring (A12) with anti-seize compound or heavy grease and install the o-ring (A12) into the body (A1).
  - b. If the valve is supplied with resilient seat, install rubber seat (A11) on the outside diameter of the seat ring (A10).
  - c. Insert new seat (A10) into the body (A1) until the seat (A10) rests against the shoulder in the body.
  - e. Align the seat ring screw holes. Insert and tighten screws (A9) evenly.

# DeZURIK

## KGC-MD KNIFE GATE VALVES

### Seat Replacement *Continued*

#### Reassembling the Valve

8. Reassemble the pipeline flange and flange bolts, or reassemble the valve in the pipeline if the valve was removed. Refer to the requirements in the "Installation" section.
9. If the actuator is a powered actuator, reconnect power to the actuator.
10. Pressurize the pipeline and inspect the valve for leaks.

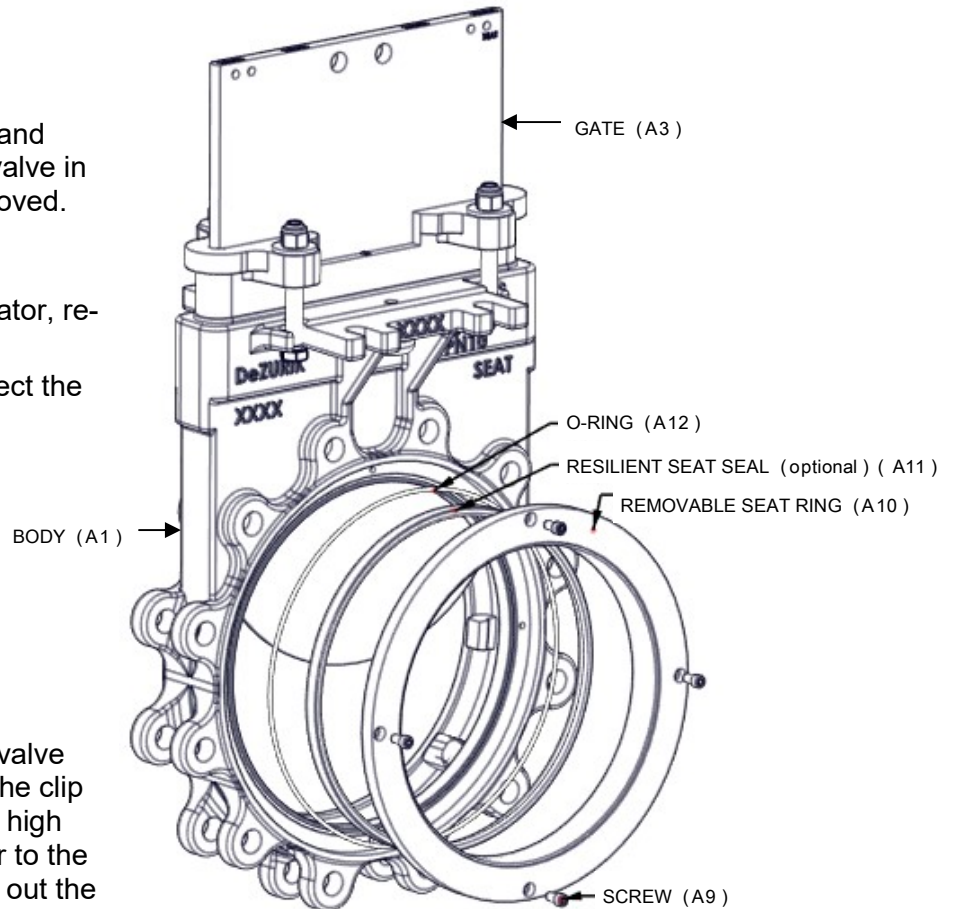

### Replacing the Gate

**NOTE:** If the gate is for a KGC MD valve with a pneumatic cylinder actuator, the clip and gate are match drilled to handle high frequency cycling. In this case, refer to the **Replacing the Clip** section and drill out the gate holes that align with the clip.

Figure 4

See Figure 2 for component identification.



#### **WARNING!**

**Pipeline pressure can cause personal injury or equipment damage. Relieve pipeline pressure before removing gate stem and packing gland nuts.**

1. Relieve the pressure in the pipeline and close the valve.



#### **WARNING!**

**Accidental operation of power actuator can cause personal injury or equipment damage. Disconnect and lock out power to actuator before servicing.**

2. If the actuator is powered, disconnect and lock out power to prevent accidental operation of the actuator.
3. Remove the pipeline flange bolts, and remove the valve from the pipeline.
4. Remove the actuator, actuator yoke, packing gland (A4), scraper rings (A2) and packing (A8) from the valve.
5. Remove and inspect the gate (A3). If the gate appears to be scratched or galled due to too-long flange bolts in the chest area of the body, check for body damage in the tapped flange holes within the chest cavity. Carefully check the seat and guides for damage. Repair or replace the body, as appropriate.

## Gate Replacement *Continued*

6. Remove and inspect the seat components.
7. Replace or reinstall the seat components as described in the “Seat Replacement” section.
8. Place the new gate (A3) in the body, in the fully closed position.
9. Replace or reinstall the packing (A8) as described in “Installing New Packing”.
10. Replace the yoke and scraper rings (A2) and actuator on the valve.
11. Adjust the actuator, yoke, and packing gland so that the valve actuates smoothly full stroke in both directions, and so that there is no evidence of binding or scratching on the gate when the gate is visible in the fully open position.
12. Reinstall the valve in the pipe line as described in the “Installation” section.
13. If the actuator is a powered actuator, reconnect power to the actuator.
14. Pressurize the pipeline and inspect the valve for leaks.
15. If the packing leaks, tighten the adjustment nuts (A7) on top of the packing gland. Tighten the nuts evenly and slowly, just enough to stop the leakage. Over tightening will cause excessive operating forces, and will decrease the life of the packing.

## Replacing the Clip

For KGC-MD valves with a pneumatic cylinder actuator, the clip and gate are match drilled to handle high frequency cycling. If the clip needs to be replaced, the following steps would be necessary to achieve a proper fit between the clip, gate and shoulder bolts:

1. Prior to disassembly of the previously utilized clip from the gate and pneumatic actuator, measure the gap between the jam nut and the clip as shown in figure 5. This distance will be utilized when reassembling the jam nut onto the new clip.
2. For valve sizes 2” through 8”, drill the clip holes to .500” [12.7mm]; for valve sizes 10” through 24”, drill the clips holes to .625” [15.88mm] and confirm the fit of the two shoulder bolts through the clip.
3. Place the clip on to the gate and roughly align the clip holes with the gate holes.
4. Insert a shoulder bolt all the way through the clip and gate. At this time, do not tighten the nut onto the shoulder bolt.
5. Try to insert the second shoulder bolt all the way through the clip and gate. It is common that due to the match drilling of the previous clip to the gate, the second shoulder bolt may not fit through the gate. In this case, with the first shoulder bolt still inserted and using the clip’s second hole as a guide, drill through the clip and gate. The hole sizes in the gate are .500” [12.7mm] for valve sizes 2” through 8”; and .625” [15.88mm] for valve sizes 10” through 24”.
6. Insert the second shoulder bolt all the way through the clip and gate.
7. Remove the shoulder bolts from the clip and thread the jam nut onto the clip to the distance measured previously.

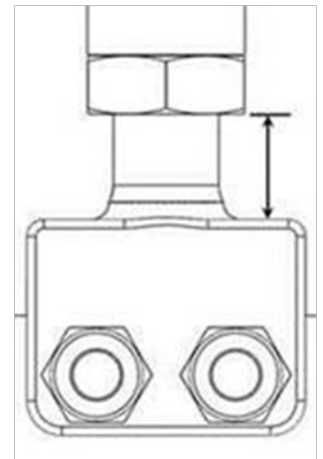

**Figure 5**

## **Replacing the Clip** *Continued*

8. Thread the clip into the pneumatic actuator's piston rod up to the jam nut but also ensure that the clip opening lines up to the gate.
9. Extend the actuator to the gate, align the clip and gate holes and install the shoulder bolts. Tighten the nuts onto the shoulder bolts and tighten the jam nut.
10. Retract the actuator and ensure the gate is retracted just out of the flow path. If the gate is in the flow path, the shoulder bolts will have to be removed since the clip will have to be adjusted by threading it into the piston rod. Reattach the clip to the gate following the steps above.

## **Purge Port Option**

When purge port option is ordered as illustrated, the intent is that the installer will connect purge lines.



### **WARNING!**

**If pipeline is under pressure with purge port plugs in place, release line pressure before removing plugs. Serious or fatal injury may occur if line is under pressure.**

---

Installation:

1. Remove all purge plugs after valve has been installed in line and before line is pressurized.
2. Connect proper purge line to the ports.
3. Pressurize purge lines and check for leaks.
4. Pressurize pipe line.

See Figure 5 for Purge Port sizes and locations.

**Purge Port Options**

VALVE SIZE		Purge Port	
INCHES	MM	A	B
3	80	1/4"	1"
4	100		
5	125		
6	150	3/8"	2"
8	200		
10	250		
12	300	1/2"	
14	350		
16	400		
18	450	3/4"	
20	500		
24	600		

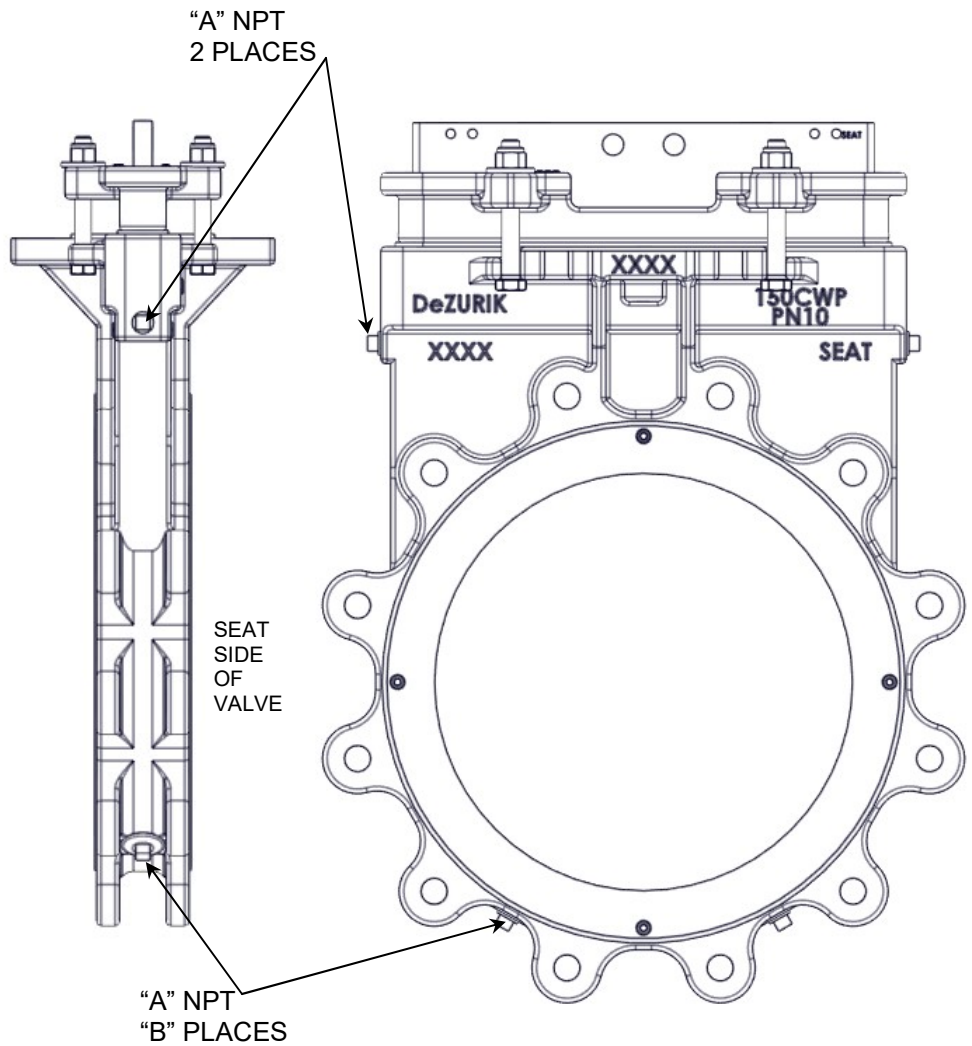

**Figure 6—Purge Port Sizes and Locations**

## Troubleshooting

<b>Condition</b>	<b>Possible Causes</b>	<b>Corrective Action</b>
Packing leaks, with no evidence of galling on gate	Packing is loose	Adjust packing gland
	Packing is worn or torn	Replace packing
Packing leaks and gate is galled	Packing is worn or torn	Replace packing and gate, check seat for damage
Valve leaks when fully closed, with no evidence of galling on gate	Seat is worn or torn	Replace seat
Valve leaks when fully closed and gate is galled	Seat is worn or torn	Replace gate and seat



## Limited Warranty

DeZURIK, Inc. ("Seller") manufactured products, auxiliaries and parts thereof that we manufacture for a period of twenty-four (24) months from date of shipment from Seller's factory, are warranted to the original purchaser only against defective workmanship and material, but only if properly stored, installed, operated, and serviced in accordance with Seller's recommendations and instructions.

For items proven to be defective within the warranty period, your exclusive remedy under this limited warranty is repair or replacement of the defective item, at Seller's option, FCA Incoterms 2020 Seller's facility with removal, transportation, and installation at your cost.

Products or parts manufactured by others but furnished by Seller are not covered by this limited warranty. Seller may provide repair or replacement for other's products or parts only to the extent provided in and honored by the original manufacturer's warranty to Seller, in each case subject to the limitations contained in the original manufacturer's warranty.

No claim for transportation, labor, or special or consequential damages or any other loss, cost or damage is being provided in this limited warranty. You shall be solely responsible for determining suitability for use and in no event shall Seller be liable in this respect.

This limited warranty does not warrant that any Seller product or part is resistant to corrosion, erosion, abrasion or other sources of failure, nor does Seller warrant a minimum length of service.

Your failure to give written notice to us of any alleged defect under this warranty within twenty (20) days of its discovery, or attempts by someone other than Seller or its authorized representatives to remedy the alleged defects therein, or failure to return product or parts for repair or replacement as herein provided, or failure to store, install, or operate said products and parts according to the recommendations and instructions furnished by Seller shall be a waiver by you of all rights under this limited warranty.

This limited warranty is voided by any misuse, modification, abuse or alteration of Seller's product or part, accident, fire, flood or other Act of God, or your failure to pay entire contract price when due.

The foregoing limited warranty shall be null and void if, after shipment from our factory, the item is modified in any way or a component of another manufacturer, such as but not limited to; an actuator is attached to the item by anyone other than a Seller factory authorized service personnel.

All orders accepted shall be deemed accepted subject to this limited warranty, which shall be exclusive of any other or previous warranty, and this shall be the only effective guarantee or warranty binding on Seller, despite anything to the contrary contained in the purchase order or represented by any agent or employee of Seller in writing or otherwise, notwithstanding, including but not limited to implied warranties.

THE FOREGOING REPAIR AND REPLACEMENT LIMITED WARRANTY IS IN LIEU OF ALL OTHER WARRANTIES, OBLIGATIONS AND LIABILITIES, INCLUDING, BUT NOT LIMITED TO, ALL WARRANTIES OF FITNESS FOR A PARTICULAR PURPOSE OR OF MERCHANTABILITY OR OTHERWISE, EXPRESSED OR IMPLIED IN FACT OR BY LAW, AND STATE SELLER'S ENTIRE AND EXCLUSIVE LIABILITY AND YOUR EXCLUSIVE REMEDY FOR ANY CLAIM IN CONNECTION WITH THE SALE AND FURNISHING OF SERVICES, GOODS OR PARTS, THEIR DESIGN, SUITABILITY FOR USE, INSTALLATION OR OPERATIONS. NEITHER ANY PERFORMANCE OR OTHER CONDUCT, NOR ANY ORAL OR WRITTEN INFORMATION, STATEMENT, OR ADVICE PREPARED BY SELLER OR ANY OF OUR EMPLOYEES OR AGENTS WILL CREATE A WARRANTY, OR IN ANY WAY INCREASE THE SCOPE OR DURATION OF THE LIMITED WARRANTY.

## Disclaimer

Metric fasteners should not be used with ASME Class 150/300 bolt holes and flange bolt patterns. If you use metric fasteners with ASME Class 150/300 bolt holes and flange bolt patterns, it may lead to product failure, injury, and loss of life. DeZURIK Inc. disclaims all liability associated with the use of metric fasteners with ASME Class 150/300 bolt holes and flange patterns, including but not limited to personal injury, loss of life, loss of product, production time, equipment, property damage, lost profits, consequential damages of any kind and environment damage and/or cleanup. Use of metric fasteners with ASME Class 150/300 bolt holes and flange bolt patterns is a misuse that voids all warranties and contractual assurances. If you use metric fasteners with ASME Class 150/300 bolt holes and flange bolt patterns, you do so at your sole risk and any liability associated with such use shall not be the responsibility of DeZURIK, Inc. In addition to the foregoing, DeZURIK's Manufacturer's Conditions apply.

## Limitation of Liability

IN NO EVENT SHALL SELLER BE LIABLE FOR ANY DIRECT, INDIRECT, SPECIAL, PUNITIVE, EXEMPLARY, OR CONSEQUENTIAL DAMAGES (INCLUDING, BUT NOT LIMITED TO; DAMAGE TO OR LOSS OF OTHER PROPERTY OR EQUIPMENT, BUSINESS INTERRUPTION, COST OF SUBSTITUTE PRODUCTS, LOSS OF TIME, LOSS OF PROFITS OR REVENUE, COST OF CAPITAL, LOSS OF USE, OR DIMINUTION IN VALUE) WHATSOEVER, AND SELLER'S LIABILITY, UNDER NO CIRCUMSTANCES, WILL EXCEED THE CONTRACT PRICE FOR THE GOODS AND/OR SERVICES FOR WHICH LIABILITY IS CLAIMED. ANY ACTION FOR BREACH OF CONTRACT BY YOU, OTHER THAN RIGHTS RESPECTING OUR LIMITED WARRANTY DESCRIBED ABOVE, MUST BE COMMENCED WITHIN 12 MONTHS AFTER THE DATE OF SALE.



Need Knife Gate Valve pricing or support for your mining project? Contact us for more assistance.

**Perth Branch**  
U2/41-45 Furnace Road  
Welshpool WA 6106  
Phone: +61 8 9353 2565  
sales@thevalvecompany.com.au

**Kalgoorlie Branch**  
2/69 Craig Road  
West Kalgoorlie WA 6430  
Phone: +61 8 9021 6668  
sales@thevalvecompany.com.au

**Brisbane Branch**  
U5/225 Queensport Road  
North Murrarie QLD 4172  
Phone: +61 7 3348 8636  
sales@thevalvecompany.com.au

**Bunbury Branch**  
Phone: +61 417 744 791  
sales@thevalvecompany.com.au