

DeZURIK KGC-HD HEAVY DUTY CAST STAINLESS STEEL KNIFE GATE VALVES

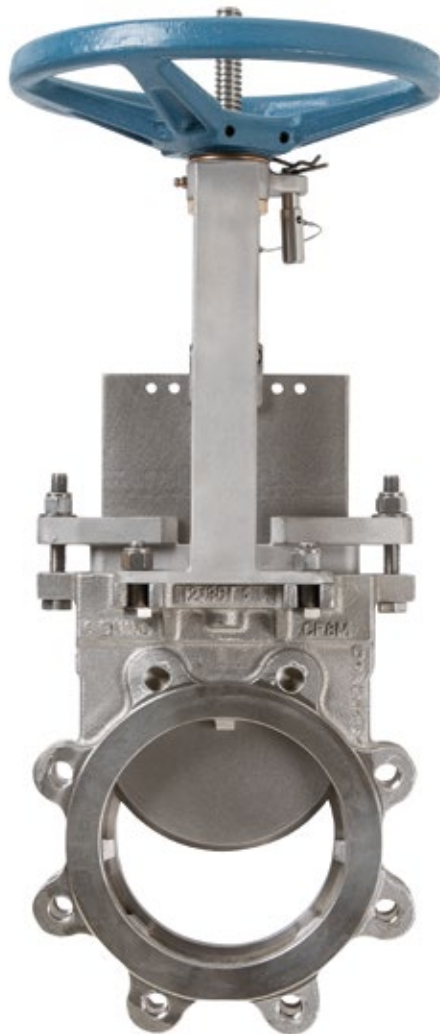

DeZURIK KGC-HD (Heavy Duty) Cast Stainless Steel Knife Gate Valves

Applications

DeZURIK KGC-HD Cast Stainless Steel Knife Gate Valves are designed for tough corrosive, abrasive liquid slurry or dry material applications including: Pulp and Paper, Mining, Waste Water, Chemical, Petrochemical, Power, Steel, Food Processing, etc.

Design and Construction

This system features a rounded cast packing chamber, rounded gate edge and many packing options to meet the demands of your specific application. All of these features together will improve sealing, extend packing life, and reduce maintenance.

Depending on what your application requires, the cast body and packing gland are available in 304, 316, 317, 254-SMO, 2205 Duplex Stainless Steel or Hastelloy C 276. Other body and gate materials are available upon request.

KGC-HD Knife Gate Valves are available in sizes 2" - 48" (50mm - 1200mm) with metal or resilient seated versions.

The actuator superstructure is heavy duty cast carbon steel or cast stainless steel to minimize corrosion. A variety of actuator options are available including: handwheels, chainwheels, bevel gears, levers, pneumatic cylinders, hydraulic cylinders, and electric motors. A full complement of accessories is also offered.



DeZURIK Exclusive Rounded Stainless Steel Gate

Gates are available in 304, 316, 317, 17-4, 254-SMO, 410, 2205 Duplex Stainless Steel or Hastelloy C for corrosion resistance. The gate has a precision ground finish on both sides to prevent packing and seat damage. The beveled knife-like gate edge with machined tooth on each side pushes away or cuts through solids in the flow stream.

- Provides superior sealing
- Improves packing life
- Requires less compression and thus reduces friction
- Eliminates sharp corners where leakage first occurs

Cast Gate Guides and Jams

The cast gate guides provide support for the moving gate and will not break off like welded guides. Cast gate jams at the bottom of the body hold the gate securely against the seat to assure positive shutoff. All KGC-HD valves can handle full reverse pressure without damage. The body has raised face end connections with drilled and tapped lugs.

High Flow Capacity

100%, round port design allows high flow capacity and minimum pressure drop. DeZURIK's KGC-HD valve seat I.D. is equal to the inside diameter of standard pipe (ASME B36.10).

Full Gasket Sealing Front and Back

For maximum gasket sealing the KGC-HD end connections conform to ASME B16.20 dimensions for Spiral-Wound gaskets.

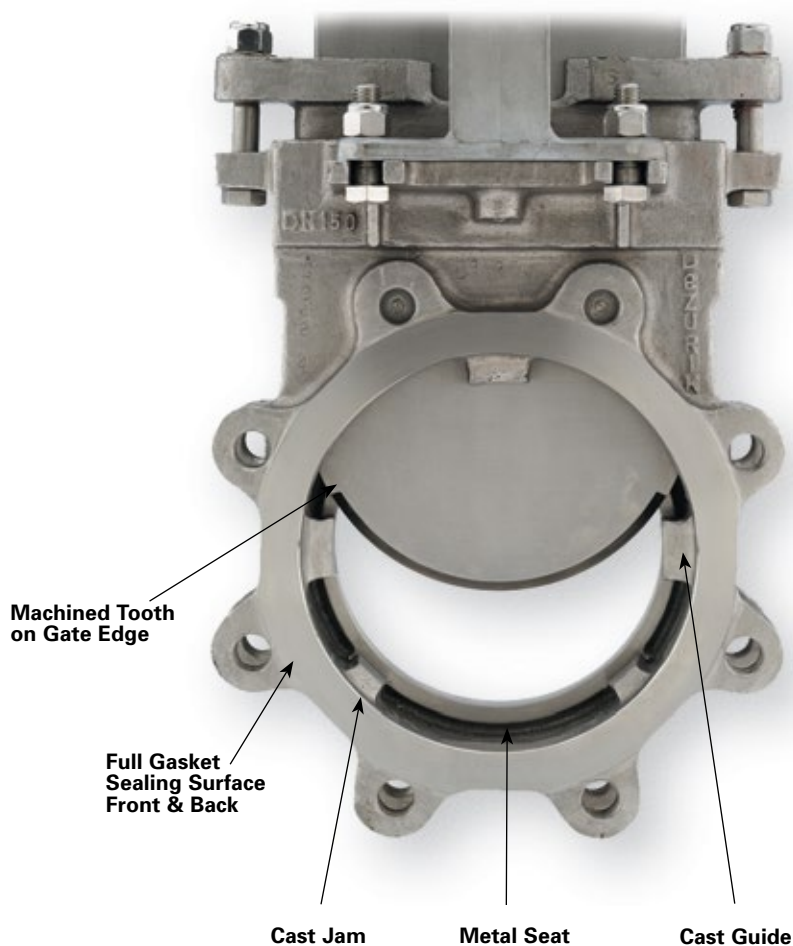

DeZURIK Exclusive Rounded Packing System Ensures Long-Life by Forming the Perfect Seal

DeZURIK KGC-HD Valves have a rounded gate edge, rounded cast packing chamber, and a packing system that ensures a long-life tight seal with minimal packing gland pressure. The packing system is available for general, moderate, severe, and high temperature applications. The system is completed by careful selection of the packing material. Temperature, pH, and media properties will determine the most suitable packing option. KGC-HD valves can be re-packed without being removed from the pipeline.

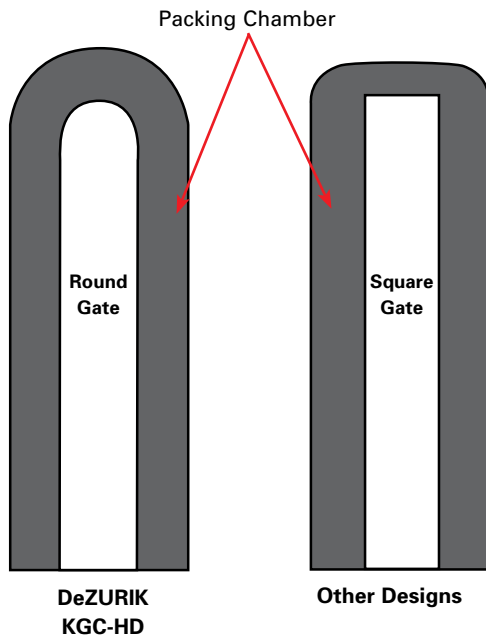

Test Data Proves – the fully rounded packing chamber and rounded gate edge require fewer packing adjustments and increase the packing cycle life compared to square gate designs

KGC-HD Rounded System Provides Superior Sealing

- Rounded cast packing chamber, rounded gated edge, and rounded packing form a perfect seal.
- Rounded gate edge cycles through packing with minimal packing disturbance; thus requiring less adjustment, and maintenance, resulting in reduced external leakage.

Putting "The System" To Work

The KGC-HD packing system includes a number of features that:

- Reduce external leakage
- Minimize friction and actuator thrust required
- Allow field replacement of packing

High Performance Packing Material Options

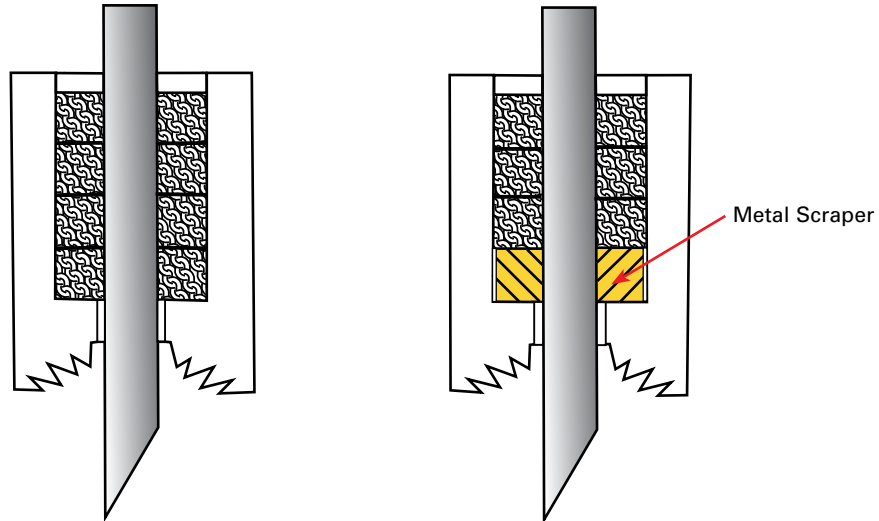

SMP
PTFE Braided Packing
to 500°F (260°C)
(pH Range: 0-14)

TDP
Dry Service, Dry PTFE
Braided Packing with
Solid PTFE Cord
to 500°F (260°C)
(pH Range: 0-14)

HTP
High Temperature
Braided Packing
to 650°F (343°C)
(pH Range: 1-12)

FGP
Food Grade Service
to 450°F (232°C)
(pH Range: 3-11)

HMP
High Temperature
Braided Packing
with Metal Scraper
to 1000°F (540°C)
(pH Range: 3-10)

Application Factors That Affect Your Packing Selection For Optimal Sealing

Compatibility with process media

- Wet or dry application
- Food grade or non food grade
- Life cycle stroke frequency
- Temperature
- pH Acid-Base level
- Scaling or crystallization on gate

Seat Options

Both metal and resilient seated valves are offered in a 100%, round port design. The integral metal seated or the replaceable 17-4 PH Stainless Steel H900 Heat Treated version is available with shutoff capability exceeding current MSS-SP81 standards.

Resilient Seated Valves

Resilient seated valves are available for applications where drip-tight shutoff is required. Unlike valves which use an o-ring seal, DeZURIK KGC-HD Valves have a replaceable resilient seat designed especially for knife gate valve applications. The resilient seat material is molded on three sides of the stainless steel seat ring. When the valve is closed, the gate is pushed against the seat and held in place by the gate jams. When the valve is open, the gate moves away from the seat, allowing clearance, which prevents seat damage and reduces operating force.

A variety of seat materials are available.

Options include:

CR - Chloroprene

NBR - Acrylonitrile-Butadiene

EPDM - Terpolymer of Ethylene, Propylene and a Diene

FKM - Fluoro Rubber

CRW - Chloroprene, off white

PTFE - Polytetrafluoroethylene, white

Reinforced PTFE - Polytetrafluoroethylene

Low Rim-Pull Force

A strong investment cast clip complements KGC-HD's robust construction. The single lead threads on the manual stem result in a lower required handwheel rim-pull force.

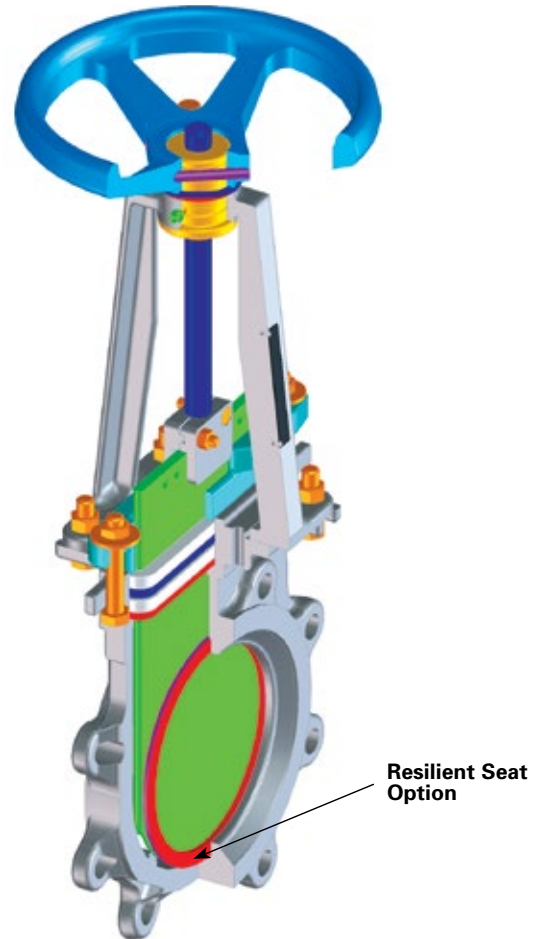

V-Orifice Design for Reliable Throttling and Modulation Control

An integral metal-seated V-port design is also available for reliable throttling control of thick slurries including paper stock. The constant V-orifice is maintained from open valve position to closed to prevent bridging or plugging and to ensure maximum control accuracy. Other orifice shapes available upon request.



Lockout Option

KGC-HD provides the latest in lockout design technology to protect both people and the environment. Unique designs for manual and automated models are available. The lockout collar for the automated models allows fine adjustment to ensure tight shutoff and maximum opening position. Lockouts are rated to withstand the maximum output of the actuators.

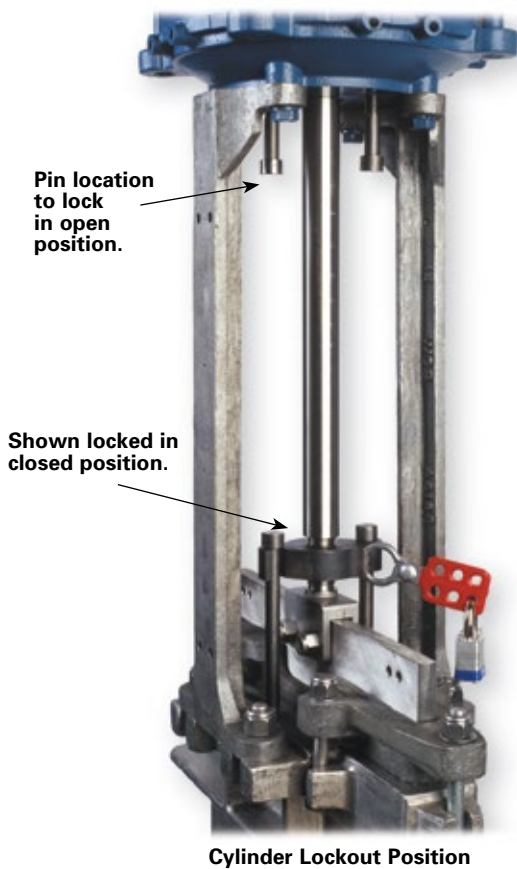

Handwheel Lockout Option

Actuators

- Handwheels
- Chainwheels
- Levers
- Bevel Gears
- Pneumatic Cylinders
- Hydraulic Cylinders
- Electric Motors

Accessories

A variety of accessories are offered as standard, including handwheel extensions, floorstands and a variety of cylinder actuator accessories for customizing the valve/actuator package to meet specific application requirements.

Options

DeZURIK Cast Knife Gate Valves may be ordered with the following options to meet your application requirements:

- Purge port connections
- Corrosion resistant cylinder actuator materials
- Lockouts
- Hardened/removable seats
- Hardened gates
- Bonnets

Materials of Construction

Item	Description	Material
A1	Body	304 Stainless Steel, ASTM A351 CF8
		316 Stainless Steel, ASTM A351 CF8M
		317 Stainless Steel, ASTM A351 CG8M
		254-SMO Stainless Steel, ASTM A351 CK3MCuN
		2205 Duplex Stainless Steel, ASTM A890 CD3MN
		Hastelloy C 276, ASTM A494 CW12MW
A2	Packing	SMP - PTFE Braided Packing to 500°F (260°C) (pH Range 0-14)
		TDP - Dry Service, Dry PTFE Braided Packing with Solid PTFE Cord to 500°F (260°C) (pH Range: 0-14)
		HTP - High Temperature Braided Packing to 650°F (343°C) (pH Range: 1-12)
		HMP - High Temperature Braided Packing with Metal Scraper Ring to 1000°F (540°C) (pH Range: 3-10)
		FGP - Food Grade Service to 450°F (232°C) (pH Range: 3-11)
A3	Gate	304 Stainless Steel, ASTM A240
		316 Stainless Steel, ASTM A240
		317 Stainless Steel, ASTM A240
		17-4 Stainless Steel H900 Heat Treated, ASTM A564
		254 - SMO Stainless Steel, ASTM A240
		2205 Duplex Stainless Steel, ASTM A276
		Hastelloy C 276, ASTM B574
410 Stainless Steel, ASTM A240		
A4	Gland	Matches Body Material
A5	Screw	304 Stainless Steel
A6	Washer	304 Stainless Steel
A7	Nut	304 Stainless Steel
A10	Seat Ring*	CR - Chloroprene to 180°F (83°C)
		NBR - Acrylonitrile-Butadiene to 180°F (83°C)
		EPDM - Terpolymer of Ethylene, Propylene and a Diene to 250°F (122°C)
		FKM - Fluoro Rubber to 400°F (204°C)
		17-4 PH Stainless Steel H900 Heat Treated
		CRW - Chloroprene, Off White to 140°F (60°C)
		PTFE - Polytetrafluoroethylene, white to 450°F (230°C)
		Reinforced PTFE - Polytetrafluoroethylene, to 500°F (260°C)
B1	Handwheel	Painted, Cast Iron
B2	Roll Pin	Carbon Steel or 420 Stainless Steel
B4	Thrust Bearing	Oil Impregnated Bronze
B5	Yoke Sleeve	Aluminum Bronze
B6	Stem	304 Stainless Steel
B7	Yoke or 304 Stainless Steel	Cast Steel or 304 Stainless Steel
B8	Screw	Zinc Plated Steel or 18-8 Stainless Steel
B9	Nut	Zinc Plated Steel or 18-8 Stainless Steel
B10	Clip	304 Stainless Steel
B23	Data Plate	316 Stainless Steel
B28	Grease Fitting	Zinc Plated Steel
B29	Screw	Zinc Plated Steel or 18-8 Stainless Steel
B30	Nut	Zinc Plated Steel or 18-8 Stainless Steel
B42	Wave Washer	304 Stainless Steel
B43	Lockout Pin	304 Stainless Steel

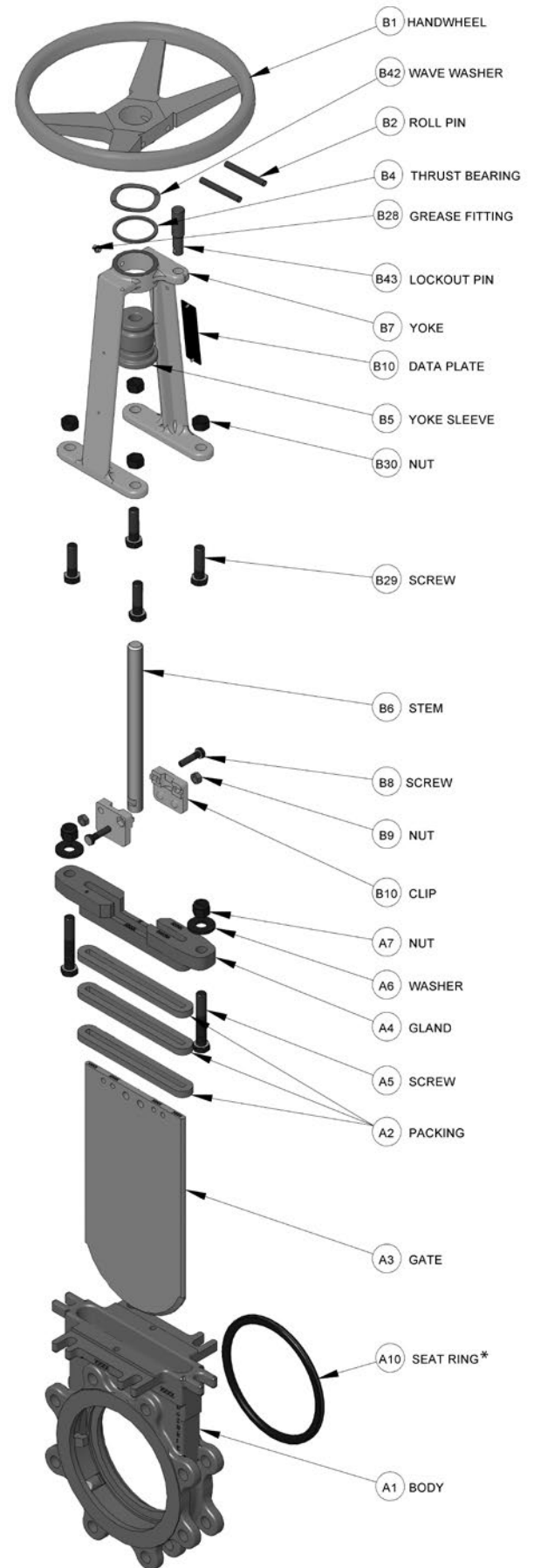

*The replaceable Seat Ring is standard on resilient-seated valves and optional on metal-seated valves. The standard integral metal seat matches the body material.

Valve Selection

Shut-Off Capabilities

Resilient Seats	Leak tight/drip tight
Metal Seats	Meet MSS SP-81 and TAPPI TIS 405-8

Pressure Ratings

2-48" (50-1200mm)	150 psi C.W.P. (1030 kPa)
Optional 30 & 36" (750 & 900mm)	100 psi C.W.P. (690 kPa)

Notes:

Valve can handle Full Reverse Pressure without damage.

Valves with Chloroprene, off white seats are limited to 50 psi (350 kPa). Contact DeZURIK with service conditions.

Flow Parameters

Round Port

Valve Size	Cv* Kv* 100% Open	K** (resistance)	Port Area (in ² /cm ²)
2"	300	0.16	3.1
50mm	260		20
3"	675	0.16	7.1
80mm	584		46
4"	1200	0.16	12.6
100mm	1040		81
5"	1900	0.16	19.6
125mm	1640		126
6"	2700	0.16	28.3
150mm	2340		183
8"	4800	0.16	50.3
200mm	4200		325
10"	7500	0.16	78.5
250mm	6500		506
12"	10800	0.16	113
300mm	9300		729
14"	13200	0.16	138
350mm	11400		890
16"	17400	0.16	183
400mm	15100		1180
18"	22300	0.16	234
450mm	19300		1510
20"	27800	0.16	291
500mm	24000		1880
22"	34000	0.16	355
550mm	29400		2290
24"	40500	0.16	425
600mm	35000		2740
26"	47800	0.16	501
650mm	41300		3230
28"	55600	0.16	583
700mm	48100		3760
30"	64000	0.16	672
750mm	55400		4340
32"	73000	0.16	767
800mm	63100		4950
36"	93000	0.16	976
900mm	80400		6300
42"	126000	0.16	1336
1050mm	109000		8620
48"	165000	0.16	1750
1200mm	142700		11290

*Cv = Flow in GPM of water at 1 psi pressure drop.

Kv = Flow in m³/hr. of water at 100 kPa pressure drop.

** K = The resistance coefficient of the valve. The constant (K) can be used to determine the equivalent length of pipe.

$L = \frac{Kx D}{f}$ Where
 L = Equivalent length of pipe in feet
 K = Resistance coefficient
 D = Pipe diameter in feet
 f = Friction factor, related to type of pipe

Applicable Standards

DeZURIK KGC-HD Knife Gate Valves are designed and/or tested to meet the following standards:

MSS SP-81	Metal Seated Valves, Stainless Steel, Bonnetless, Flanged Knife Gate Valves
ASME B16.5 2-24" (50-600mm)	Flanges and Flanged Fittings, ANSI 150 Conforms to related drilling dimensions
ASME 16.47 26-48" (650-1200mm)	Large diameter Steel Flanges. Series A. Conforms to related dimensions
International Standards	Conforms to flanged bolt guides — JIS 10; DIN 10 and DIN 16; ISO 7005-1/PN10 and 7005-2/PN16; BS 4504/PN10 and BS 4504/PN16; and AS 2129 Tables D and E; SANS 1123-1000 and SANS 1123-1600
TAPPI TIS 405-8	Recommendations for Stainless Steel, Bonnetless, Flanged, Wafer Knife Gate Valves. Revoked by TAPPI, Same as MSS SP-81

Flow Parameters

V-port 60 Degrees

Valve Size	Cv* Kv* 100% Open	K** (resistance)	Port Area (in ² /cm ²)
2"	89	1.80	1.9
50mm	77		12
3"	210	1.63	4.3
80mm	584		28
4"	386	1.53	7.7
100mm	330		50
5"	665	1.27	11.5
125mm	580		74
6"	900	1.42	17.2
150mm	780		111
8"	1660	1.32	30.6
200mm	1400		197
10"	2320	1.65	42.0
250mm	2000		271
12"	3490	1.52	61.9
300mm	3000		399
14"	4650	1.27	80.8
350mm	4000		521
16"	6110	1.29	106
400mm	5300		680
18"	8000	1.23	138
450mm	6900		890
20"	10100	1.20	170
500mm	8700		1100
22"	11900	1.28	213
550mm	10300		1370
24"	15100	1.14	250
600mm	13100		1610
26"	16800	1.28	300
650mm	14500		1940
28"	19500	1.29	350
700mm	16900		2260
30"	23900	1.14	389
750mm	20700		2510
32"	25600	1.30	460
800mm	22100		2970
36"	35200	1.11	568
900mm	30400		3660
42"	44100	1.32	800
1050mm	38100		5160
48"	57800	1.33	1050
1200mm	50000		6770

Valve Selection

Valve and Actuator Weights

Valve Size	Basic Valve	With Lever	With Handwheel	With Chainwheel	With Bevel Gear Handwheel*	With Cylinder			
						Size	lbs.	Kg.	
2" 50mm	10 4.5	20 9	20 9	32 14.5	—	4" (100mm)	29	13	
	3" 80mm	16 7	37 17	27 12	39 18	88 40	4" (100mm)	37	17
4" 100mm		24 11	48 22	36 16	48 22	96 43.5	4" (100mm)	45	20
	5" 125mm	32 14.5	60 27	51 23	66 30	108 49	6" (150mm)	63	29
6" 150mm		38 17	66 30	57 26	75 34	113 51	4" (100mm)	58	26
	8" 200mm	65 30	98 44.5	86 39	101 46	144 65	6" (150mm)	76	35
10" 250mm		103 47	157 71	141 85	179 81	191 87	8" (200mm)	88	40
	12" 300mm	148 67	213 97	187 85	227 103	241 109	4" (100mm)	63	29
14" 350mm		199 90	N/A	265 120	284 129	303 137	6" (150mm)	81	37
	16" 400mm	272 123	N/A	341 155	358 162	380 172	8" (200mm)	93	42
18" 450mm		361 164	N/A	433 197	449 204	473 215	6" (150mm)	112	51
	20" 500mm	518 235	N/A	593 269	653 296	637 289	8" (200mm)	124	56
22" 550mm		622 282	N/A	698 317	N/A	760 345	8" (200mm)	174	79
	24" 600mm	725 329	N/A	803 364	N/A	882 400	10" (250mm)	220	100
26" 650mm		918 417	N/A	N/A	N/A	1104 501	12" (300mm)	257	117
	28" 700mm	1111 503	N/A	N/A	N/A	1325 601	8" (200mm)	225	102
30" 750mm		1446 656	N/A	N/A	N/A	1594 723	10" (250mm)	270	122
	32" 800mm	1700 772	N/A	N/A	N/A	1825 828	12" (300mm)	309	140
36" 900mm		2204 1000	N/A	N/A	N/A	2366 1073	10" (250mm)	332	151
	42" 1050mm	3600 1634	N/A	N/A	N/A	3908 1774	12" (300mm)	372	169
48" 1200mm		4997 2266	N/A	N/A	N/A	5450 2474	10" (250mm)	409	186
							12" (300mm)	449	204
							14" (350mm)	495	225
							12" (300mm)	551	250
							14" (350mm)	602	273
							16" (400mm)	813	369
							12" (300mm)	712	323
							14" (350mm)	760	345
							16" (400mm)	982	445
							12" (300mm)	830	377
							14" (350mm)	881	400
							16" (400mm)	1101	500
							18" (450mm)	1144	519
							12" (300mm)	947	430
							14" (350mm)	1001	454
							16" (400mm)	1219	553
							18" (450mm)	1262	572
							12" (300mm)	1200	544
							14" (350mm)	1251	568
							16" (400mm)	1524	692
							18" (450mm)	1578	716
							20" (500mm)	1711	777
							12" (300mm)	1417	643
							14" (350mm)	1467	666
							16" (400mm)	1648	748
							18" (450mm)	1830	830
							20" (500mm)	1963	891
							12" (300mm)	1718	780
							14" (350mm)	1768	802
							16" (400mm)	1985	900
							18" (450mm)	2205	1000
							20" (500mm)	2365	1073
							12" (300mm)	1901	862
							14" (350mm)	1951	886
							16" (400mm)	2121	963
							18" (450mm)	2300	1044
							20" (500mm)	2426	1101
							14" (350mm)	2541	1153
							16" (400mm)	2755	1250
							18" (450mm)	2987	1355
							20" (500mm)	3150	1428
							On Application		
							On Application		

Pounds
Kilograms

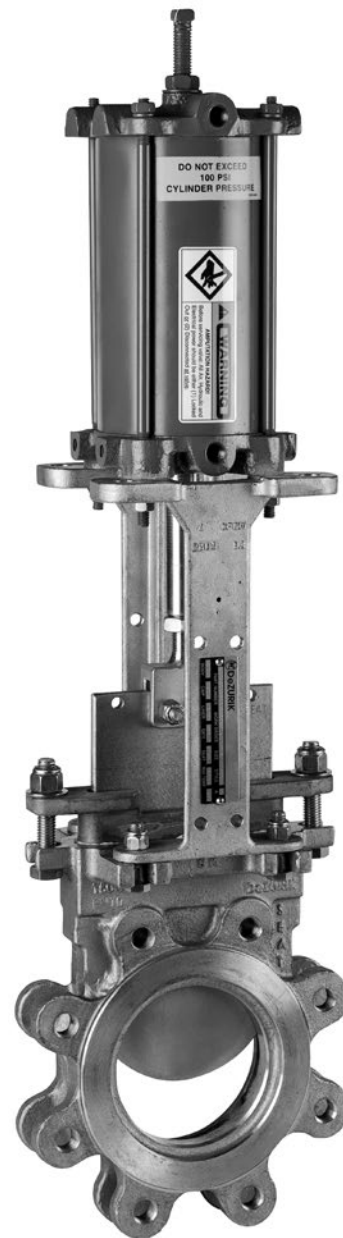

Note: Weights are approximate and do not include crating.

* For Bevel Gear with Chainwheel, add the following weight to the bevel gear with handwheel weight:
 2-18" add 7 lbs. (3kg)
 20-24" add 26 lbs. (12kg)
 30" add 74 lbs. (34kg)
 36" add 68 lbs. (31kg)

Ordering

To order, simply complete the valve order code from information shown. An ordering example is shown for your reference.

<p>Valve Style Give valve style code as follows:</p> <p>KGC = Cast Stainless Steel Knife Gate Valve</p>
--

<p>Valve Size Give valve size code as follows:</p> <table> <tr> <td>2 = 2" (50mm)</td> <td>20 = 20" (500mm)</td> </tr> <tr> <td>3 = 3" (80mm)</td> <td>22 = 22" (550mm)</td> </tr> <tr> <td>4 = 4" (100mm)</td> <td>24 = 24" (600mm)</td> </tr> <tr> <td>5 = 5" (125mm)</td> <td>26 = 26" (650mm)</td> </tr> <tr> <td>6 = 6" (150mm)</td> <td>28 = 28" (700mm)</td> </tr> <tr> <td>8 = 8" (200mm)</td> <td>30 = 30" (750mm)</td> </tr> <tr> <td>10 = 10" (250mm)</td> <td>32 = 32" (800mm)</td> </tr> <tr> <td>12 = 12" (300mm)</td> <td>36 = 36" (900mm)</td> </tr> <tr> <td>14 = 14" (350mm)</td> <td>42 = 42" (1050mm)</td> </tr> <tr> <td>16 = 16" (400mm)</td> <td>48 = 48" (1200mm)</td> </tr> <tr> <td>18 = 18" (450mm)</td> <td></td> </tr> </table>	2 = 2" (50mm)	20 = 20" (500mm)	3 = 3" (80mm)	22 = 22" (550mm)	4 = 4" (100mm)	24 = 24" (600mm)	5 = 5" (125mm)	26 = 26" (650mm)	6 = 6" (150mm)	28 = 28" (700mm)	8 = 8" (200mm)	30 = 30" (750mm)	10 = 10" (250mm)	32 = 32" (800mm)	12 = 12" (300mm)	36 = 36" (900mm)	14 = 14" (350mm)	42 = 42" (1050mm)	16 = 16" (400mm)	48 = 48" (1200mm)	18 = 18" (450mm)	
2 = 2" (50mm)	20 = 20" (500mm)																					
3 = 3" (80mm)	22 = 22" (550mm)																					
4 = 4" (100mm)	24 = 24" (600mm)																					
5 = 5" (125mm)	26 = 26" (650mm)																					
6 = 6" (150mm)	28 = 28" (700mm)																					
8 = 8" (200mm)	30 = 30" (750mm)																					
10 = 10" (250mm)	32 = 32" (800mm)																					
12 = 12" (300mm)	36 = 36" (900mm)																					
14 = 14" (350mm)	42 = 42" (1050mm)																					
16 = 16" (400mm)	48 = 48" (1200mm)																					
18 = 18" (450mm)																						

<p>Body Style Give body style code as follows:</p> <p>HD = Heavy Duty</p>
--

<p>End Connection Give end connection code as follows:</p> <p>F1 = ANSI 150 UNC Tapping for Threads F110 = ISO 7005/PN10 Drilling F116 = ISO 7005/PN16 Drilling F1DA = AS2129 Table D Drilling F1EA = AS2129 Table E Drilling F1UN⁽¹⁾ = ANSI 150 UN-8 Tapping for Threads F1S10 = SANS1123-1000 F1S16 = SANS1123-1600</p> <p>Optional End Connections F1T = ANSI 150 Through Bolting</p> <p>On Application F1J1 = JIS 10 Drilling</p>
--

<p>Body Material Give body material code as follows:</p> <p>Standard S1 = 304 Stainless Steel S2 = 316 Stainless Steel S3 = 317 Stainless Steel</p> <p>On Application HC = Hastelloy C S6 = 254 Stainless Steel S10 = 2205 Duplex Stainless Steel</p>
--

<p>Packing Material Give packing material code as follows:</p> <p>Standard Packing SMP = PTFE Braided Packing to 500°F (260°C) (pH Range 0-14)</p> <p>Optional Packing TDP = Dry Service, Dry PTFE Braided Packing with Solid PTFE Cord to 500°F (260°C) (pH Range: 0-14) HTP = High Temperature Braided Packing to 650°F (343°C) (pH Range: 1-12) HMP = High Temperature Braided Packing with Metal Scraper Ring to 1000°F (540°C) (pH Range: 3-10) FGP = Food Grade Service to 450°F (232°C) (pH Range: 3-11)</p>

<p>Gate Material (3) Give gate material code as follows:</p> <p>Standard Gate Materials S1 = 304 Stainless Steel (Standard for S1 body material) S2 = 316 Stainless Steel (Standard for S2 body material) S3 = 317 Stainless Steel (Standard for S3 body material)</p> <p>Optional Gate Materials S5 = 17-4 Stainless Steel H900 Heat Treated (Used with S1, S2, & S3 body materials)</p> <p>On Application S6 = 254-SMO Stainless Steel (Used with S6 body material) S8 = 410 Stainless Steel (Used with S1, S2 & S3 body materials) S10 = 2205 Duplex Stainless Steel (Used with S2, S3 OR S10 body materials) HC = Hastelloy C (Used with HC body materials)</p>

<p>Seat Material (2) Give seat material code as follows:</p> <p>Standard Seat Materials M = Metal V = V-Orifice All Metal CR = Chloroprene to 180°F (83°C) NBR = Acrylonitrile-Butadiene to 180°F (83°C) EPDM = Terpolymer of Ethylene, Propylene and a Diene to 250°F (122°C)</p> <p>Optional Seat Materials FKM = Fluoro Rubber to 400°F (204°C) S5D = 17-4 PH Stainless Steel H900 Heat Treated</p> <p>On Application CRW = Chloroprene, Off White to 140°F (60°C) PTFE or RTFE</p>

<p>Standard Options Give option code as follows:</p> <p>ARRA = ARRA Compliant PSA = Purge Ports in Seat Area PCA = Purge Ports in Chest Area PSC = Purge Ports in Seat and Chest Area CMC = Certificate of Material Conformance CRT = Certified Physical and Chemical Test Reports — = Optional Coating — = DeZURIK Standard Test Certification P100 = 30" and 36" (750 and 900mm) valves with 100 psi (690 kPa) rating</p>
--

- Notes:
- (1) Applies to valves 18" (450mm) and larger. Flange bolt hole threads are 8 threads per inch in accordance with ANSI, API and MSS standards.
 - (2) The limiting factor in valve selection is the lowest temperature of the packing or seat.
 - (3) Gate material limitations by body style in parentheses.

Ordering Example:
KGC,6,HD,F1,S2,SMP,S2-CR*Actuator

Manual Actuators

Lever Actuators

Lever actuators can be furnished on 2-12" (50-300mm) valves for applications where rapid valve operation is required or where space prevents use of a standard handwheel or bevel gear actuator. Maximum pressure differential required for valves with lever actuators should not exceed the limits listed. Maximums are based on the operating force for each valve size. Lever actuators are carbon steel only. SMP packing recommended with MN-LV.

To order, add the lever actuator code to the basic valve order code.

Ordering Example:

KGC,6,HD,F1,S2,SMP,S2-M*MN-LV-CS

Lever Actuator

Valve Size	Order Code Carbon Steel (CS) Yoke	Maximum Pressure Differential psi/kPa
2-4" 50-100mm	MN-LV-CS	75 520
5-6" 125-150mm	MN-LV-CS	45 310
8" 200mm	MN-LV-CS	25 170
10" 250mm	MN-LV-CS	20 140
12" 300mm	MN-LV-CS	14 100

Handwheel and Chainwheel Actuators

All 2-24" (50-600mm) valves can be furnished with handwheel actuators, and 2-20" (50-500mm) with chainwheel actuators. To order handwheel or chainwheel actuators, add the appropriate order code to the basic valve order code. Refer to information on bevel gear actuators for use on dry solids, paper stock, slurries or when pressure exceeds limits shown. Order chain for chainwheel actuators as a separate item.

Handwheel Actuator

Valve Size	Order Code	Order Code	Maximum Pressure Differential psi/kPa
	Carbon Steel (CS) Yoke	304 SST (S1) Yoke	
2-4" 50-100mm	MN-HD8-CS	MN-HD8-S1	150 1030
5-8" 125-200mm	MN-HD12-CS	MN-HD12-S1	150 1030
10-12" 250-300mm	MN-HD16-CS	MN-HD16-S1	150 1030
14" 350mm	MN-HD20-CS*	MN-HD20-S1*	125 860
16" 400mm	MN-HD20-CS*	MN-HD20-S1*	100 680
18" 450mm	MN-HD20-CS*	MN-HD20-S1*	75 515
20" 500mm	MN-HD20-CS*	MN-HD20-S1*	50 340
22" 550mm	MN-HD20-CS*	MN-HD20-S1*	25 170
24" 600mm	MN-HD20-CS*	MN-HD20-S1*	25 170

*Bevel gear actuators recommended for dry solids, paper stocks, slurries, or when pressure exceeds limits shown.

Ordering Example:

KGC,6,HD,F1,S2,SMP,S2-M*MN-HD12-CS

Chainwheel Actuator

Valve Size	Order Code	Order Code	Maximum Pressure Differential psi/kPa
	Carbon Steel (CS) Yoke	304 SST (S1) Yoke	
2-4" 50-100mm	MN-CW8-CS	MN-CW8-S1	150 1030
5-8" 125-200mm	MN-CW12-CS	MN-CW12-S1	150 1030
10-12" 250-300mm	MN-CW20-CS	MN-CW20-S1	150 1030
14" 350mm	MN-CW20-CS*	MN-CW20-S1*	125 860
16" 400mm	MN-CW20-CS*	MN-CW20-S1*	100 680
18" 450mm	MN-CW20-CS*	MN-CW20-S1*	75 515
20" 500mm	MN-CW20-CS*	MN-CW20-S1*	50 340

*Bevel gear actuators recommended for dry solids, paper stocks, slurries, or when pressure exceeds limits shown.

Ordering Example:

KGC,4,HD,F1,S2,SMP,S2-CR*MN-CW8-S1

Manual Actuators

Bevel Gear Actuators

Bevel gear actuators are available on 3-48" (80-1200mm) valves with handwheel or chainwheel actuators. Bevel gear actuators provide vertical mounting of the handwheel or chainwheel, or can be used where space limitations prohibit the use of a standard handwheel or chainwheel. A mechanical advantage makes large valve operation easier and faster.

Bevel Gear Handwheel Actuators

Valve Size	Order Code	Order Code	Maximum Pressure Differential psi/kPa
	Carbon Steel (CS) Yoke	304 SST (S1) Yoke	
3-18" 80-450mm	MNB-HD12-CS	MNB-HD12-S1	150 1030
20-24" 500-600mm	MNB-HD16-CS	MNB-HD16-S1	150 1030
30-42" 750-1050mm	MNB-HD30-CS	MNB-HD30-S1	150* 1030*
48" 1200mm	MNB-HD36-CS	MNB-HD36-S1	150 1030

Ordering Example:

KGC,14,HD,F1,S2,SMP,S2-CR*MNB-HD12-CS

Note:

For alternate mounting of bevel gear actuators, add -90, -180 or -270 after the actuator code and as 2nd line information on the order.

* Maximum pressure of 30" (750mm) and 36" (900mm) valves with P100 option is 100psi.

Bevel Gear Chainwheel Actuators

Valve Size	Order Code	Order Code	Maximum Pressure Differential psi/kPa
	Carbon Steel (CS) Yoke	304 SST (S1) Yoke	
3-18" 80-450mm	MNB-CW12-CS	MNB-CW12-S1	150 1030
20-24" 500-600mm	MNB-CW20-CS	MNB-CW20-S1	150 1030
30-42" 750-1050mm	MNB-CW30-CS	MNB-CW30-S1	150* 1030*
48" 1200mm	MNB-CW36-CS	MNB-CW36-S1	150 1030

Ordering Example:

KCG,14,HD,F1,S2,SMP,S2-CR*MNB-CW12-CS-90
Actuator mounted at 90 degrees

Manual Actuator Accessories

Chain for Chainwheel Actuators

Order as a separate item by giving the correct code and specify required length of chain as second line information. One closing link is supplied with the Chainwheel Actuator.

Order Code	Description
ACC*CN102	Steel, Zinc Plated 3/16
ACC*CN103	Galvanized 3/16
ACC*CN106	316 Stainless Steel 3/16

Ordering Example:

ACC*CN102

Chain 12 feet long (366cm)

Extension for Handwheel or 2" Nut Extension

Provides extension of the handwheel or nut to allow remote operation – normally from above. The extension includes fittings and extension pipe with handwheel or nut mounted. To order, specify description and extension length from center line of valve to handwheel or nut.

Order Code	Description
ENHD	Extension for Handwheel
ENTS	Extension for Nut

Ordering Example:

Handwheel: KGC,14,HD,F1,S2,SMP,S2-CR*MN-HD20-CS,ENHD

Nut: KGC,14,HD,F1,S2,SMP,S2-CR*MN-N-CS,ENTS

Center line of valve to handwheel nut 72 inches (1829mm).

Lockout Device

Available on all sizes of handwheel, bevel gear handwheel and cylinder actuated valves. To order, add a comma and the order code "LK" after the actuator code.

Ordering Example:

KGC,14,HD,F1,S2,SMP,S2-CR*MNB-HD12-CS,LK

Floorstand

A floorstand for handwheel actuated valves allows operation from above. Includes floorstand with gate position indicator, handwheel, fittings and extension. To order, specify length from center line of valve to base of floorstand. This dimension must be at least twice the dimension from center line to handwheel. For non-rising stems only. Floor stands for use with rising stems are available on application.

Ordering Example:

KGC,14,HD,F1,S2,SMP,S2-CR*MN-HD20-CS

Except with floorstand. Center line of valve to base of floorstand 72 inches (1829mm).

Deflection Cones

To prolong valve life in particularly demanding services, deflection cones are available in 316 stainless steel or abrasion resistant cast iron per ASTM A532 with Brinell Hardness of at least 500 BHN. Order as a separate line item by giving the correct code and valve size.

Order Code	Description
DCS23 - Valve Size	316 Stainless Steel
DCNH23 - Valve Size	Abrasion Resistant Cast Iron

Ordering Example:

Cylinder Actuators

On-Off Cylinder Actuators

DeZURIK cylinder actuators are available with double-acting pneumatic or hydraulic cylinders for on/off or positioning services. Supply pressure is 60 or 80 psi (410 or 550 kPa). To order, add the proper code from the on/off column of the table to the valve order code. Specify hydraulic media if other than oil.

Positioning Cylinder Actuators

DeZURIK cylinder actuators are available with pneumatic or electronic positioners for throttling control. Positioners are enclosed and mounted on the superstructure.

Actuator Sizing

60 psi (410 kPa) Air Supply

Valve Size	Order Code	Order Code	Maximum Pressure Differential psi/kPa			
			On/Off		Positioning	
			Dry Solids, Slurries, Paper Stock	Liquids & Gases	Dry Solids, Slurries, Paper Stock	Liquids & Gases
2 & 3" 50 & 80mm	CY-PC4-CS	CY-PC4-S1	150	150	150	150
			1030	1030	1030	1030
4" 100mm	CY-PC4-CS	CY-PC4-S1	100	150	75	75
			690	1030	515	515
5 & 6" 125 & 150mm	CY-PC6-CS	CY-PC6-S1	150	N/R	150	150
			1030		1030	1030
			N/A	50	N/A	N/A
8" 200mm	CY-PC6-CS	CY-PC6-S1	125	150	75	100
			860	1030	515	690
			150	N/R	150	150
10" 250mm	CY-PC8-CS	CY-PC8-S1	75	125	50	50
			515	860	340	340
			150	1030	125	860
12" 300mm	CY-PC8-CS	CY-PC8-S1	100	150	75	100
			690	1030	515	690
			150	N/R	125	150
14" 350mm	CY-PC10-CS	CY-PC10-S1	1030	N/R	860	1030
			N/R	N/R	150	N/R
			75	125	50	50
16" 400mm	CY-PC10-CS	CY-PC10-S1	515	860	340	340
			125	150	100	125
			860	1030	690	860
18" 450mm	CY-PC12-CS	CY-PC12-S1	150	N/R	150	150
			1030		1030	1030
			50	75	25	50
20" 500mm	CY-PC12-CS	CY-PC12-S1	340	515	170	340
			100	150	75	75
			690	1030	515	515
22" 550mm	CY-PC14-CS	CY-PC14-S1	150	N/R	100	125
			1030		690	860
			N/R	N/R	150	150
24" 600mm	CY-PC14-CS	CY-PC14-S1	50	125	25	50
			340	860	170	340
			125	150	75	100
26" 650mm	CY-PC16-CS	CY-PC16-S1	860	1030	515	690
			150	N/R	125	150
			1030		860	1030
28" 700mm	CY-PC16-CS	CY-PC16-S1	100	150	50	75
			690	1030	340	515
			150	N/R	100	125
30" 750mm	CY-PC18-CS	CY-PC18-S1	N/R	N/R	150	150
					1030	1030
			50	100	N/A	25
32" 800mm	CY-PC14-CS	CY-PC14-S1	340	690	170	340
			100	150	50	75
			690	1030	340	515
34" 850mm	CY-PC16-CS	CY-PC16-S1	150	N/R	100	125
			1030		690	860
			N/R	N/R	150	150
36" 900mm	CY-PC18-CS	CY-PC18-S1	N/R	N/R	150	150
					1030	1030
			50	100	N/A	25

N/R = Not required. Use next smaller actuator.

N/A = Not available. Use larger actuator or contact DeZURIK.

Cylinder Actuators

Actuator Sizing

60 psi (410 kPa) Air Supply

Valve Size	Order Code	Order Code	Maximum Pressure Differential psi/kPa			
			On/Off		Positioning	
	Carbon Steel (CS) Yoke	304 SST (S1) Yoke	Dry Solids, Slurries, Paper Stock	Liquids & Gases	Dry Solids, Slurries, Paper Stock	Liquids & Gases
24" 600mm	CY-PC12-CS	CY-PC12-S1	25 170	75 515	N/A	N/A
	CY-PC14-CS	CY-PC14-S1	75 515	150 1030	50 340	50 340
	CY-PC16-CS	CY-PC16-S1	150 1030	N/R	75 515	100 690
	CY-PC18-CS	CY-PC18-S1	N/R	N/R	150 1030	150 1030
26" 650mm	CY-PC12-CS	CY-PC12-S1	N/A	75 515	N/A	N/R
	CY-PC14-CS	CY-PC14-S1	50 340	125 860	25 170	50 340
	CY-PC16-CS	CY-PC16-S1	125 860	150 1030	75 515	75 515
	CY-PC18-CS	CY-PC18-S1	150 1030	N/R	100 690	150 1030
	CY-PC20-CS	CY-PC20-S1	N/R	N/R	150 1030	N/R
28" 700mm	CY-PC12-CS	CY-PC12-S1	N/A	50 340	N/A	N/A
	CY-PC14-CS	CY-PC14-S1	50 340	100 690	N/A	25 170
	CY-PC16-CS	CY-PC16-S1	75 515	150 1030	50 340	75 515
	CY-PC18-CS	CY-PC18-S1	150 1030	N/R	75 515	125 860
	CY-PC20-CS	CY-PC20-S1	N/R	N/R	150 1030	150 1030
30" 750mm 100 CWP (P100)	CY-PC14-CS	CY-PC14-S1	25 170	75 515	N/A	N/A
	CY-PC16-CS	CY-PC16-S1	75 515	100 690	25 170	50 340
	CY-PC18-CS	CY-PC18-S1	100 690	N/R	75 515	75 515
	CY-PC20-CS	CY-PC20-S1	N/R	N/R	100 690	100 690
30" 750mm 150 CWP	CY-PC14-CS	CY-PC14-S1	25 170	75 515	N/A	N/A
	CY-PC16-CS	CY-PC16-S1	75 515	150 1030	25 170	50 340
	CY-PC18-CS	CY-PC18-S1	125 860	N/R	75 515	75 515
	CY-PC20-CS	CY-PC20-S1	150 1030	N/R	125 860	150 1030
32" 800mm	CY-PC14-CS	CY-PC14-S1	25 170	75 515	N/A	N/A
	CY-PC16-CS	CY-PC16-S1	50 340	125 860	25 170	25 170
	CY-PC18-CS	CY-PC18-S1	100 690	150 1030	50 340	75 515
	CY-PC20-CS	CY-PC20-S1	150 1030	N/R	75 515	125 860
36" 900mm 100 CWP (P100)	CY-PC14-CS	CY-PC14-S1	N/A	50 340	N/A	N/A
	CY-PC16-CS	CY-PC16-S1	25 170	75 515	N/A	N/A
	CY-PC18-CS	CY-PC18-S1	75 515	100 690	25 170	50 340
	CY-PC20-CS	CY-PC20-S1	100 690	N/R	50 340	75 515
36" 900mm 150 CWP	CY-PC14-CS	CY-PC14-S1	N/A	50 340	N/A	N/A
	CY-PC16-CS	CY-PC16-S1	25 170	75 515	N/A	N/A
	CY-PC18-CS	CY-PC18-S1	75 515	150 1030	25 170	50 340
	CY-PC20-CS	CY-PC20-S1	100 690	N/R	50 340	75 515
42 & 48" 1050 & 1200mm	Contact DeZURIK for cylinder actuator sizing.					

N/R = Not required. Use next smaller actuator.

N/A = Not available. Use larger actuator or contact DeZURIK.

Cylinder Actuators

Actuator Sizing

80 psi (550 kPa) Air Supply

Valve Size	Order Code	Order Code	Maximum Pressure Differential psi/kPa			
			On/Off		Positioning	
	Carbon Steel (CS) Yoke	304 SST (S1) Yoke	Dry Solids, Slurries, Paper Stock	Liquids & Gases	Dry Solids, Slurries, Paper Stock	Liquids & Gases
2 & 3" 50 & 80mm	CY-PC4-CS	CY-PC4-S1	150 1030	150 1030	150 1030	150 1030
	CY-PC4-CS	CY-PC4-S1	150 1030	150 1030	100 690	150 1030
4" 100mm	CY-PC6-CS	CY-PC6-S1	N/R	N/R	150 1030	N/R
	CY-PC4-CS	CY-PC4-S1	50 340	75 515	25 170	25 170
5 & 6" 125 & 150mm	CY-PC6-CS	CY-PC6-S1	150 1030	150 1030	125 860	150 1030
	CY-PC8-CS	CY-PC8-S1	N/R	N/R	150 1030	N/R
	CY-PC6-CS	CY-PC6-S1	100 690	150 1030	75 515	75 515
8" 200mm	CY-PC8-CS	CY-PC8-S1	150 1030	N/R	150 1030	150 1030
	CY-PC8-CS	CY-PC8-S1	150 1030	150 1030	100 690	125 860
10" 250mm	CY-PC10-CS	CY-PC10-S1	N/R	N/R	150 1030	150 1030
	CY-PC8-CS	CY-PC8-S1	100 690	150 1030	75 515	100 690
12" 300mm	CY-PC10-CS	CY-PC10-S1	150 1030	N/R	150 1030	150 1030
	CY-PC10-CS	CY-PC10-S1	125 860	150 1030	100 690	125 860
14" 350mm	CY-PC12-CS	CY-PC12-S1	150 1030	N/R	150 1030	150 1030
	CY-PC10-CS	CY-PC10-S1	100 690	150 1030	75 515	100 690
16" 400mm	CY-PC12-CS	CY-PC12-S1	150 1030	N/R	125 860	150 1030
	CY-PC14-CS	CY-PC14-S1	N/R	N/R	150 1030	N/R
	CY-PC12-CS	CY-PC12-S1	150 1030	150 1030	100 690	125 860
18" 450mm	CY-PC14-CS	CY-PC14-S1	N/R	N/R	150 1030	150 1030
	CY-PC12-CS	CY-PC12-S1	125 860	150 1030	75 515	75 515
20" 500mm	CY-PC14-CS	CY-PC14-S1	150 1030	N/R	125 860	150 1030
	CY-PC16-CS	CY-PC16-S1	N/R	N/R	150 1030	N/R
	CY-PC12-CS	CY-PC12-S1	100 690	150 1030	50 340	75 515
22" 550mm	CY-PC14-CS	CY-PC14-S1	150 1030	N/R	100 690	125 860
	CY-PC16-CS	CY-PC16-S1	N/R	N/R	150 1030	150 1030
	CY-PC12-CS	CY-PC12-S1	75 515	150 1030	25 170	50 340
24" 600mm	CY-PC14-CS	CY-PC14-S1	150 1030	N/R	100 690	125 860
	CY-PC16-CS	CY-PC16-S1	N/R	N/R	150 1030	150 1030
	CY-PC12-CS	CY-PC12-S1	50 340	125 860	25 170	25 170
26" 650mm	CY-PC14-CS	CY-PC14-S1	125 860	150 1030	75 515	75 515
	CY-PC16-CS	CY-PC16-S1	150 1030	N/R	125 860	150 1030
	CY-PC18-CS	CY-PC18-S1	N/R	N/R	750 1030	N/R
	CY-PC12-CS	CY-PC12-S1	50 340	100 690	N/A	25 170
28" 700mm	CY-PC14-CS	CY-PC14-S1	100 690	150 1030	50 340	75 515
	CY-PC16-CS	CY-PC16-S1	150 1030	N/R	100 690	125 860
	CY-PC18-CS	CY-PC18-S1	N/R	N/R	150 1030	150 1030
	CY-PC12-CS	CY-PC12-S1	50 340	100 690	N/A	25 170

N/R = Not required. Use next smaller actuator.

N/A = Not available. Use larger actuator or contact DeZURIK.

Cylinder Actuators

Actuator Sizing

80 psi (550 kPa) Air Supply

Valve Size	Order Code	Order Code	Maximum Pressure Differential psi/kPa			
			On/Off		Positioning	
	Carbon Steel (CS) Yoke	304 SST (S1) Yoke	Dry Solids, Slurries, Paper Stock	Liquids & Gases	Dry Solids, Slurries, Paper Stock	Liquids & Gases
30" 750mm 100 CWP (P100)	CY-PC12-CS	CY-PC12-S1	25 170	75 515	N/A	N/A
	CY-PC14-CS	CY-PC14-S1	75 515	100 690	50 340	50 340
	CY-PC16-CS	CY-PC16-S1	100 690	N/R	75 515	100 690
	CY-PC18-CS	CY-PC18-S1	N/R	N/R	100 690	N/R
30" 750mm 150 CWP	CY-PC12-CS	CY-PC12-S1	25 170	75 515	N/A	N/A
	CY-PC14-CS	CY-PC14-S1	75 515	150 1030	50 340	50 340
	CY-PC16-CS	CY-PC16-S1	150 1030	N/R	75 515	100 690
	CY-PC18-CS	CY-PC18-S1	N/R	N/R	125 860	150 1030
	CY-PC20-CS	CY-PC20-S1	N/R	N/R	150 1030	N/R
32" 800mm	CY-PC12-CS	CY-PC12-S1	25 170	50 340	N/A	N/A
	CY-PC14-CS	CY-PC14-S1	50 340	125 860	25 170	50 340
	CY-PC16-CS	CY-PC16-S1	100 690	150 1030	50 340	75 515
	CY-PC18-CS	CY-PC18-S1	150 1030	N/R	100 690	150 1030
	CY-PC20-CS	CY-PC20-S1	N/R	N/R	150 1030	N/R
36" 900mm 100 CWP (P100)	CY-PC14-CS	CY-PC14-S1	25 170	75 515	N/A	25 170
	CY-PC16-CS	CY-PC16-S1	75 515	100 690	50 340	50 340
	CY-PC18-CS	CY-PC18-S1	100 690	N/R	75 515	100 690
	CY-PC20-CS	CY-PC20-S1	N/R	N/R	100 690	N/R
36" 900mm 150 CWP	CY-PC14-CS	CY-PC14-S1	25 170	75 515	N/A	25 170
	CY-PC16-CS	CY-PC16-S1	75 515	150 1030	50 340	50 340
	CY-PC18-CS	CY-PC18-S1	125 860	N/R	75 515	100 690
	CY-PC20-CS	CY-PC20-S1	150 1030	N/R	125 860	150 1030
42 & 48" 1050 & 1200mm	Contact DeZURIK for cylinder actuator sizing.					

N/R = Not required. Use next smaller actuator.

N/A = Not available. Use larger actuator or contact DeZURIK.

Cylinder Actuator Accessories

Positioners

DeZURIK cylinder actuators are available with pneumatic, electro-pneumatic or digital positioners for throttling control.

Air Filter Regulator

The DeZURIK Air Filter Regulator is designed to provide clean, accurate air pressure to actuators and positioners.

Four-Way Solenoid Valves

Solenoid valves may be ordered mounted and piped as part of a complete valve/actuator assembly or as

Speed Control Valves

Speed Control Valves are available for controlling valve opening or closing speed with pneumatic actuators. The speed of operation is adjustable. To order mounted, add the appropriate code to the valve and actuator order code.

Speed Control	Order Code
Two speed controls	SP
One control to close	SPC
One control to open	SPO

Ordering Example:

KGC,4,HD,F1,S1,SMPS1-M*CY-PC6-CS,SP

Cylinder Actuator Accessories

Position Indicating Switches

Position Indicating Switches are available for use on double-acting cylinder actuators. Order as part of a complete valve/actuator assembly by adding the appropriate code from the table below to the valve and actuator order code. Two switches will automatically be set to indicate full open and full closed positions.

Two Switches - Open/Closed

Quantity/Description	Switch Type	Rating	Manufacturer	Order Code
2 SPDT	Mechanical	Nema 1, 3, 4, 4X, 6, 6P, 12 and 13	Honeywell LSA1A-1A	SE649
2 DPDT	Mechanical	Nema 1, 3, 4, 4X, 6, 6P, 12 and 13	Honeywell LSA2B-1A	SE524
2 SPDT	Mechanical	Nema 1, 3, 4, 6, 7 (Class 1, Division 1, Groups B, C, D), 9 (Class 2, Division 1, Groups E, F, G), 13	Honeywell LSXA3K-1A	SEH95
2 DPDT	Mechanical	Nema 1, 3, 4, 6, 7 (Class 1, Division 1, Groups B, C, D), 9 (Class 2, Division 1, Groups E, F, G), 13	Honeywell LSXA4L-1A	SEH96
2 SPDT, SST Housing	Proximity	CSA/FM Class 1, Division 1, Explosion Proof	GO 73-13526-A2	SEHK4
2 SPDT, SST Housing	Proximity	CSA Class I, Div 2, Hazardous Locations, (Groups A,B,C,D), Class II, (Groups E,F,G), Class III	GO 11-11124-A2	SEH94
2 SPDT, SST Housing	Proximity	Nema 1, 3, 4, 4X, 6, 6P, 12 and 13	Stonel HK3077SG and HK3077SR	SEHK3

One Switch - Open

Quantity/Description	Switch Type	Rating	Manufacturer	Order Code
1 SPDT	Mechanical	Nema 1, 3, 4, 4X, 6, 6P, 12 and 13	Honeywell LSA1A-1A	SEJ40
1 DPDT	Mechanical	Nema 1, 3, 4, 4X, 6, 6P, 12 and 13	Honeywell LSA2B-1A	SEJ42
1 SPDT	Mechanical	Nema 1, 3, 4, 6, 7 (Class 1, Division 1, Groups B, C, D), 9 (Class 2, Division 1, Groups E, F, G), 13	Honeywell LSXA3K-1A	SEJ46
1 DPDT	Mechanical	Nema 1, 3, 4, 6, 7 (Class 1, Division 1, Groups B, C, D), 9 (Class 2, Division 1, Groups E, F, G), 13	Honeywell LSXA4L-1A	SEJ44
1 SPDT, SST Housing	Proximity	CSA/FM Class 1, Division 1, Explosion Proof	GO 73-13526-A2	SEHK5
1 SPDT, SST Housing	Proximity	CSA Class I, Div 2, Hazardous Locations, (Groups A,B,C,D), Class II, (Groups E,F,G), Class III	GO 11-11124-A2	SEJ38
1 SPDT, SST Housing	Proximity	Nema 1, 3, 4, 4X, 6, 6P, 12 and 13	Stonel HK3077SG	SEK37

One Switch - Closed

Quantity/Description	Switch Type	Rating	Manufacturer	Order Code
1 SPDT	Mechanical	Nema 1, 3, 4, 4X, 6, 6P, 12 and 13	Honeywell LSA1A-1A	SEJ41
1 DPDT	Mechanical	Nema 1, 3, 4, 4X, 6, 6P, 12 and 13	Honeywell LSA2B-1A	SEJ43
1 SPDT	Mechanical	Nema 1, 3, 4, 6, 7 (Class 1, Division 1, Groups B, C, D), 9 (Class 2, Division 1, Groups E, F, G), 13	Honeywell LSXA3K-1A	SEJ47
1 DPDT	Mechanical	Nema 1, 3, 4, 6, 7 (Class 1, Division 1, Groups B, C, D), 9 (Class 2, Division 1, Groups E, F, G), 13	Honeywell LSXA4L-1A	SEJ45
1 SPDT, SST Housing	Proximity	CSA/FM Class 1, Division 1, Explosion Proof	GO 73-13526-A2	SEHK6
1 SPDT, SST Housing	Proximity	CSA Class I, Div 2, Hazardous Locations, (Groups A,B,C,D), Class II, (Groups E,F,G), Class III	GO 11-11124-A2	SEJ39
1 SPDT, SST Housing	Proximity	Nema 1, 3, 4, 4X, 6, 6P, 12 and 13	Stonel HK3077SR	SEK87

Electric Motor Actuators

DeZURIK Knife Gate Valves can be furnished with electric motor actuators including Limatorque, Auma, Rotork, E.I.M. and others.

When ordering electric motor actuators, specify valve order code, shutoff pressure, service conditions (flowing media and installation direction); type of application (on/off or throttling); speed of operation; NEMA rating (4, 7, submersible, etc.); electrical characteristics (voltage and phase); actuator accessories and controls as per specification requirements.

Dimensions

Basic Valve with Lever Actuator

Valve Size	Dimensions						
	F	H	J	L	M	N	P
2" 50mm	3.0 76	1.88 48	5.75 146	15.96 405	14.78 375	4.38 111	8.00 203
3" 80mm	3.75 95	2.00 51	7.75 197	21.78 553	17.75 451	5.38 137	17.88 454
4" 100mm	4.50 114	2.00 51	7.88 200	29.40 747	19.87 505	6.12 155	24.12 613
5" 125mm	5.00 127	2.25 57	8.62 219	37.50 953	22.76 578	7.38 187	19.81 503
6" 150mm	5.50 140	2.25 57	8.62 219	42.00 1067	23.32 592	7.38 187	16.81 427
8" 200mm	6.75 171	2.75 70	9.38 238	58.12 1476	27.68 703	7.88 200	21.12 536
10" 250mm	8.00 203	2.75 70	11.25 286	68.19 1732	35.13 892	10.62 270	21.53 699
12" 300mm	9.50 241	3.00 76	11.25 286	76.03 1931	39.47 1003	12.69 322	33.44 849

Inches
Millimeters

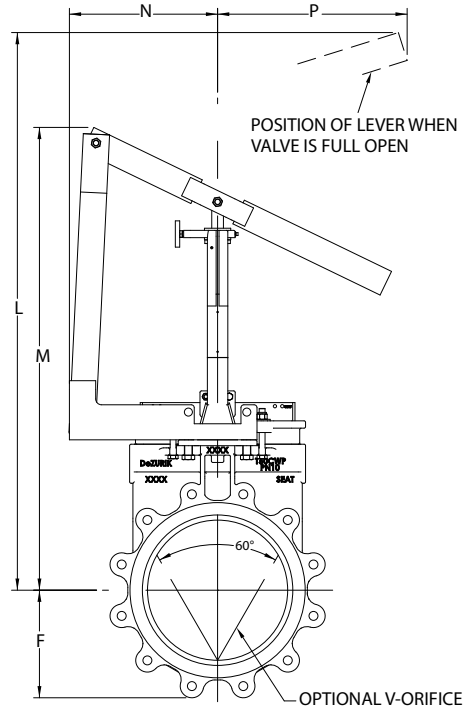
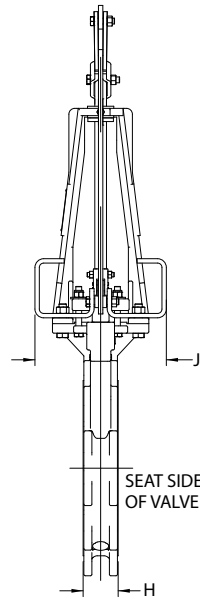

Basic Valve with Handwheel Actuator

Valve Size	Dimensions					
	F	H	J	L	M	N
2" 50mm	3.00 76	1.88 48	4.00 102	14.93 379	12.90 328	8.00 203
3" 80mm	3.75 95	2.00 51	4.75 121	16.65 423	14.62 371	8.00 203
4" 100mm	4.50 114	2.00 51	5.00 127	19.93 506	16.90 429	8.00 203
5" 125mm	5.00 127	2.25 57	5.75 146	24.30 618	19.56 497	12.00 305
6" 150mm	5.50 140	2.25 57	5.75 146	25.88 657	21.07 535	12.00 305
8" 200mm	6.75 171	2.75 70	6.38 162	31.43 798	24.65 626	12.00 305
10" 250mm	8.00 203	2.75 70	8.25 210	39.13 994	30.00 762	16.00 406
12" 300mm	9.50 241	3.00 76	8.25 210	44.75 1137	33.63 854	16.00 406
14" 350mm	10.50 267	3.00 76	8.25 210	54.75 1391	40.82 1037	20.00 508
16" 400mm	11.75 298	3.50 89	8.69 221	58.44 1484	42.38 1076	20.00 508
18" 450mm	12.50 318	3.50 89	9.06 230	67.75 1721	49.69 1262	20.00 508
20" 500mm	13.75 349	4.50 114	9.19 233	71.31 1811	51.25 1302	20.00 508
22" 550mm	15.5 394	4.50 114	9.19 233	77.22 1961	55.36 1406	20.00 508
24" 600mm	16.00 406	4.50 114	9.19 233	83.29 2116	59.22 1504	20.00 508

Inches
Millimeters

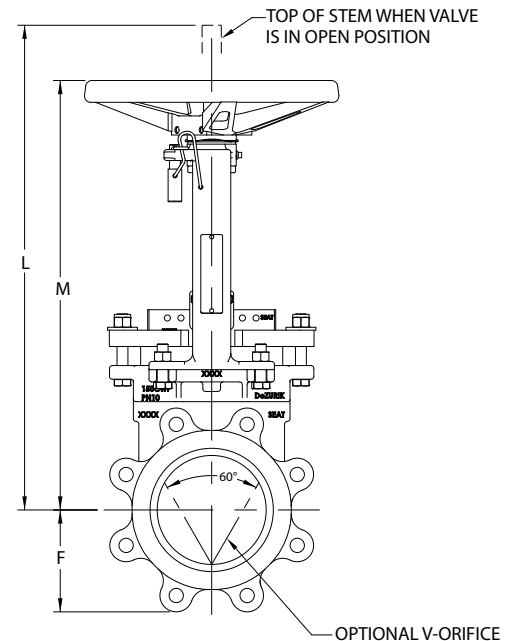
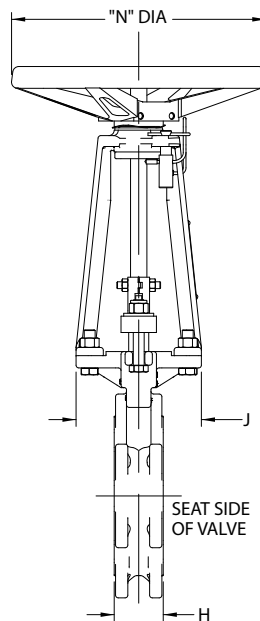

Dimensions

Bevel Gear Handwheel Actuator

Valve Size	Dimensions					
	F	H	J	L	M	N
3"	3.75	2.00	4.75	22.00	16.09	12.00
80mm	95	51	121	559	409	305
4"	4.50	2.00	5.00	24.30	18.37	12.00
100mm	114	51	127	617	467	305
5"	5.00	2.25	5.75	28.70	20.76	12.00
125mm	127	57	146	729	527	305
6"	5.50	2.25	5.75	30.30	22.29	12.00
150mm	140	57	146	769	566	305
8"	6.75	2.75	6.38	35.80	25.84	12.00
200mm	171	70	162	910	656	305
10"	8.00	2.75	8.25	46.50	31.54	12.00
250mm	203	70	210	1181	801	305
12"	9.50	3.00	8.25	50.20	35.16	12.00
300mm	241	76	210	1275	893	305
14"	10.50	3.00	8.25	56.70	37.78	12.00
350mm	267	76	210	1440	960	305
16"	11.75	3.50	8.69	60.40	41.47	12.00
400mm	298	89	221	1534	1053	305
18"	12.50	3.50	9.06	69.90	47.08	12.00
450mm	318	89	230	1775	1195	305
20"	13.75	4.50	9.19	73.50	50.59	16.00
500mm	349	114	233	1867	1285	406
24"	16.00	4.50	9.19	81.50	58.57	16.00
600mm	406	114	233	2070	1488	406
26"	17.13	4.63	9.50	100.95	64.49	30.00
650mm	435	117	241	2564	1638	762
28"	18.25	5.00	10.69	104.83	68.37	30.00
700mm	464	127	271	2663	1737	762
30"*	19.38	5.50	11.25	105.03	73.09	30.00
750mm	492	140	286	2668	1856	762
32"	20.88	6.00	11.25	113.20	76.74	30.00
800mm	530	152	286	2875	1949	762
36"*	23.00	6.00	11.25	122.53	84.59	30.00
900mm	584	152	286	3112	2149	762
42"	26.50	6.50	13.50	146.28	96.91	36.00
1050mm	673	165	343	3716	2462	914
48"	29.75	7.00	18.50	194.87	116.85	36.00
1200mm	756	178	470	4950	2968	914

Inches
Millimeters

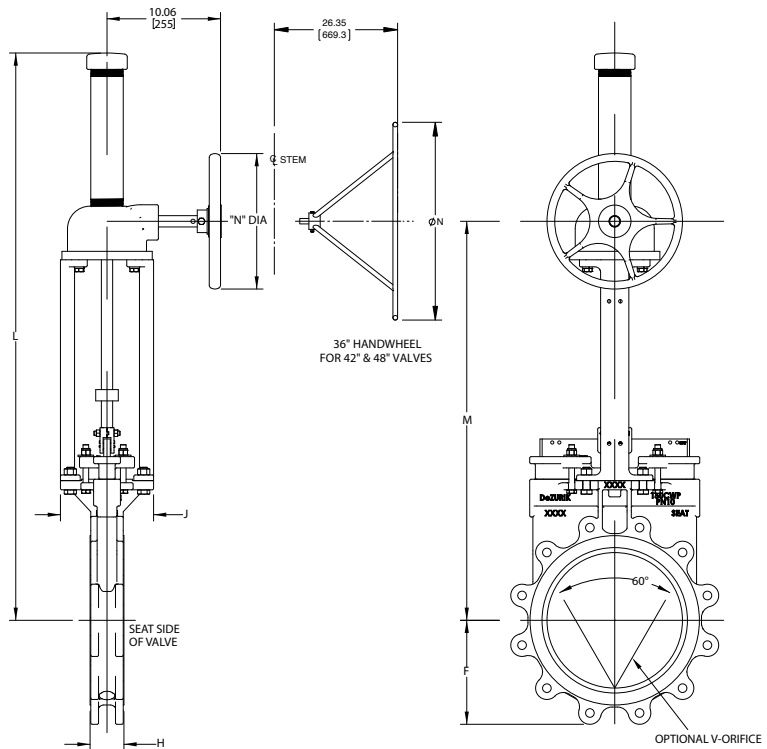

* 100 psi, face-to-face (H dimension) on 30" and 36" (750 and 900mm) is 4.62" (117mm)

Dimensions

Basic Valve with Cylinder Actuator

Valve Size	Dimensions		
	F	H	J
2" 50mm	3.00 76	1.88 48	4.00 102
3" 80mm	3.75 95	2.00 51	4.75 121
4" 100mm	4.50 114	2.00 51	5.00 127
5" 125mm	5.00 127	2.25 57	5.75 146
6" 150mm	5.50 140	2.25 57	5.75 146
8" 200mm	6.75 171	2.75 70	6.38 162
10" 250mm	8.00 203	2.75 70	8.25 210
12" 300mm	9.50 241	3.00 76	8.25 210
14" 350mm	10.50 267	3.00 76	8.25 210
16" 400mm	11.75 298	3.50 89	8.69 221
18" 450mm	12.50 318	3.50 89	9.06 230
20" 500mm	13.75 349	4.50 114	9.19 233
22" 550mm	15.50 394	4.50 114	9.19 233
24" 600mm	16.00 406	4.50 114	9.19 233
26" 650mm	17.13 435	4.63 117	9.50 241
28" 700mm	18.25 464	5.00 127	10.69 271
30"* 750mm	19.38 492	5.50 140	11.25 286
32" 800mm	20.88 530	6.00 152	11.25 286
36"* 900mm	23.00 584	6.00 152	11.25 286
42" 1050mm	26.50 673	6.50 165	13.50 343
48" 1200mm	Contact DeZURIK		

Inches
Millimeters

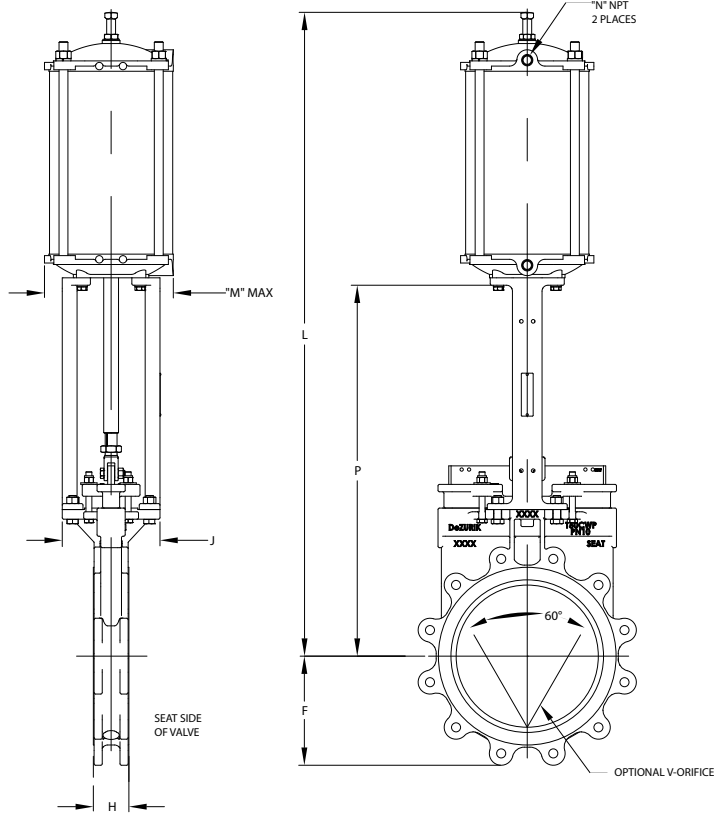

2-16" (50-400mm) Valves

Actuator Number	Dimensions											M	N
	L												
	2" 50mm	3" 80mm	4" 100mm	5" 125mm	6" 150mm	8" 200mm	10" 250mm	12" 300mm	14" 350mm	16" 400mm			
CY-PC4	22.26 565	23.98 609	26.26 667	30.64 778	32.18 817	—	—	—	—	—	—	5.38 137	1/4
CY-PC6	—	—	27.61 701	32.00 813	33.56 852	39.11 993	47.13 1197	None	—	—	—	7.88 200	1/4
CY-PC8	—	—	—	32.38 822	33.94 862	39.49 1003	49.57 1259	53.19 1351	59.06 1500	62.74 1594	10.50 267	1/2	
CY-PC10	—	—	—	—	—	—	50.97 1295	54.59 1387	60.35 1533	64.03 1626	13.00 330	1/2	
CY-PC12	—	—	—	—	—	—	50.94 1294	54.56 1386	60.70 1542	64.38 1635	15.00 381	1/2	
CY-PC14	—	—	—	—	—	—	—	—	—	63.68 1617	17.00 432	1/2	

* 100 psi, face-to-face (H dimension) on 30" and 36" (750 and 900mm) is 4.62" (117mm)

Inches
Millimeters

18-48" (450-1200mm) Valves

Actuator Number	Dimensions												M	N
	L													
	18" 450mm	20" 500mm	22" 550mm	24" 600mm	26" 650mm	28" 700mm	30" 750mm	32" 800mm	36" 900mm	42" 1050mm	48" 1200mm			
CY-PC10	73.59 1869	77.16 1960	—	—	—	—	—	—	—	—	—	—	13.00 330	1/2
CY-PC12	73.935 1878	77.495 1968	85.52 2172	89.475 2273	—	—	—	—	—	—	—	—	15.00 381	1/2
CY-PC14	73.24 1860	76.81 1951	85.52 2172	88.78 2255	95.38 2423	101.44 2577	108.19 2748	—	—	—	—	—	17.00* 432	1/2
CY-PC16	70.25 1784	75.94 1929	82.00 2083	87.91 2233	95.50 2426	101.56 2580	108.31 2751	113.94 2894	125.81 3196	—	—	Contact DeZURIK	17.00 432	1/2
CY-PC18	—	—	—	88.16 2239	95.75 2432	101.81 2585	108.56 2757	114.19 2900	126.06 3202	143.19 3637	—	—	19.00 483	3/4
CY-PC20	—	—	—	—	—	102.06 2592	109.81 2789	115.44 2932	126.31 3208	143.44 3643	—	—	21.00 533	3/4

* M dimension on 26-30" (650-750mm) is 14.75" (375mm)

Inches
Millimeters



Need Knife Gate Valve pricing or support for your mining project? Contact us for more assistance.

Perth Branch

U2/41-45 Furnace Road
Welshpool WA 6106
Phone: +61 8 9353 2565
sales@thevalvecompany.com.au

Kalgoorlie Branch

2/69 Craig Road
West Kalgoorlie WA 6430
Phone: +61 8 9021 6668
sales@thevalvecompany.com.au

Brisbane Branch

U5/225 Queensport Road
North Murrarie QLD 4172
Phone: +61 7 3348 8636
sales@thevalvecompany.com.au

Bunbury Branch

Phone: +61 417 744 791
sales@thevalvecompany.com.au