

DeZURIK KSL-LA SLURRY KNIFE GATE VALVES

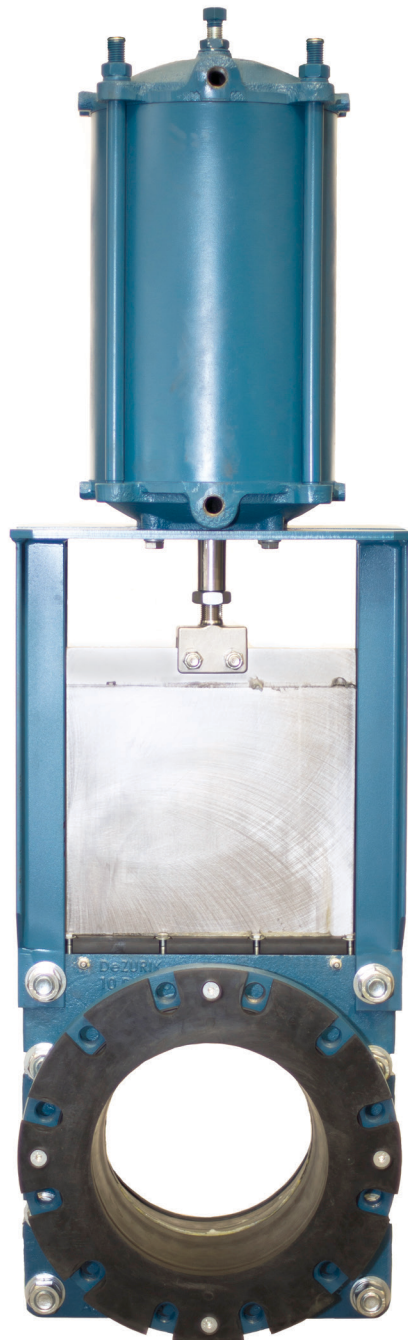

Slurry Knife Gate

Design and Construction

DeZURIK's KSL-LA Slurry Knife Gate Valves are designed for on-off (isolation) service for applications consisting of abrasive, high solids content, wet or dry media. KSL-LA Slurry Knife Gate Valves are ideally suited for applications in the mining, power, and aggregate industries.

KSL-LA Knife Gate Valves are available in sizes 2-24" (50-600mm) with larger sizes available on application. Temperature ratings to 177°F (81°C) as standard, and up to 300°F (150°C) with high-temperature optional seat materials. Standard pressure rating on 2-24" valves is 100 psi (690kPa), with higher pressures available with optional gate materials.

Depending on the application requirements, the cast body is available in Ductile Iron, Carbon Steel and various Stainless Steel or higher alloy materials.

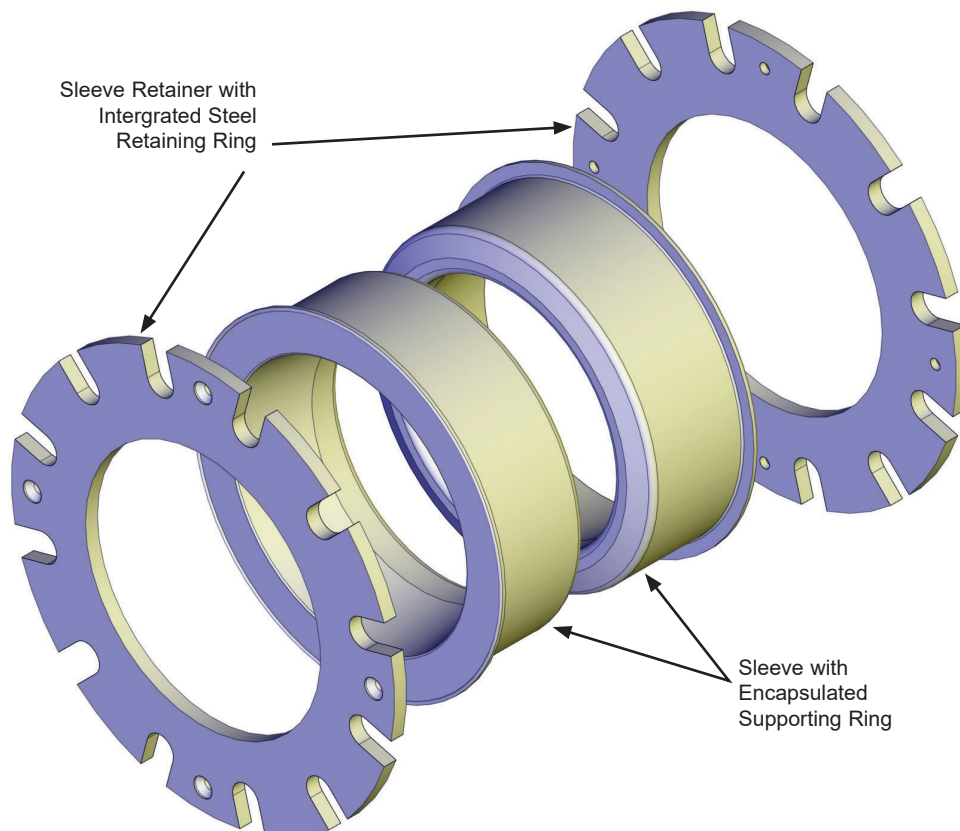
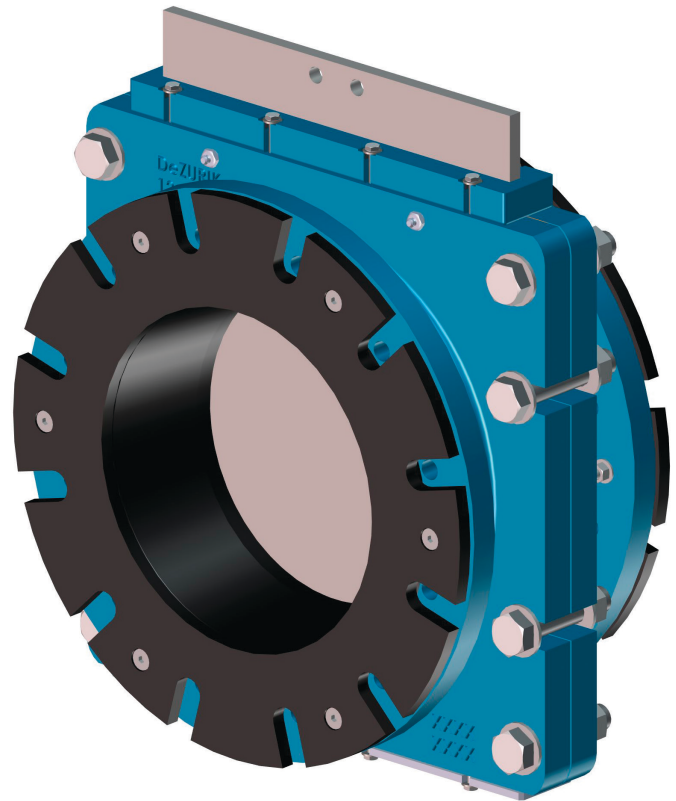

Features include:

- Full flanged design with flange drilling per ASME B16.5 Class 150, DIN and BS standards, PN10 and PN16, and SANS 1123-1000 and 1600 Australian Table D & E (AS 2129) available.
- Bi-directional, drip tight shutoff to full pressure rating.
- Field replaceable sleeves with encapsulated supporting ring.
- Body construction allows for easy repairs.
- Full port reduces turbulence and pressure drop across the valve.
- Sleeve compression eliminates cavity where solids can collect.
- Sleeve design eliminates gate and stem packing.
- Sleeve design eliminates the requirement for flange gaskets.
- Straight vertical plane superstructure allows for easy installation of accessories.
- Gate fully retracts out of the flow path in the open position.
- Open / Closed position lock-outs optional.
- Optional gate coatings provide additional abrasion resistance and a non-stick (lubrication infused) surface that reduces actuating forces and extends sleeve life.
- Integral Lifting Lugs standard on sizes 12" (300mm) and larger.
- Flushing drain plates available.

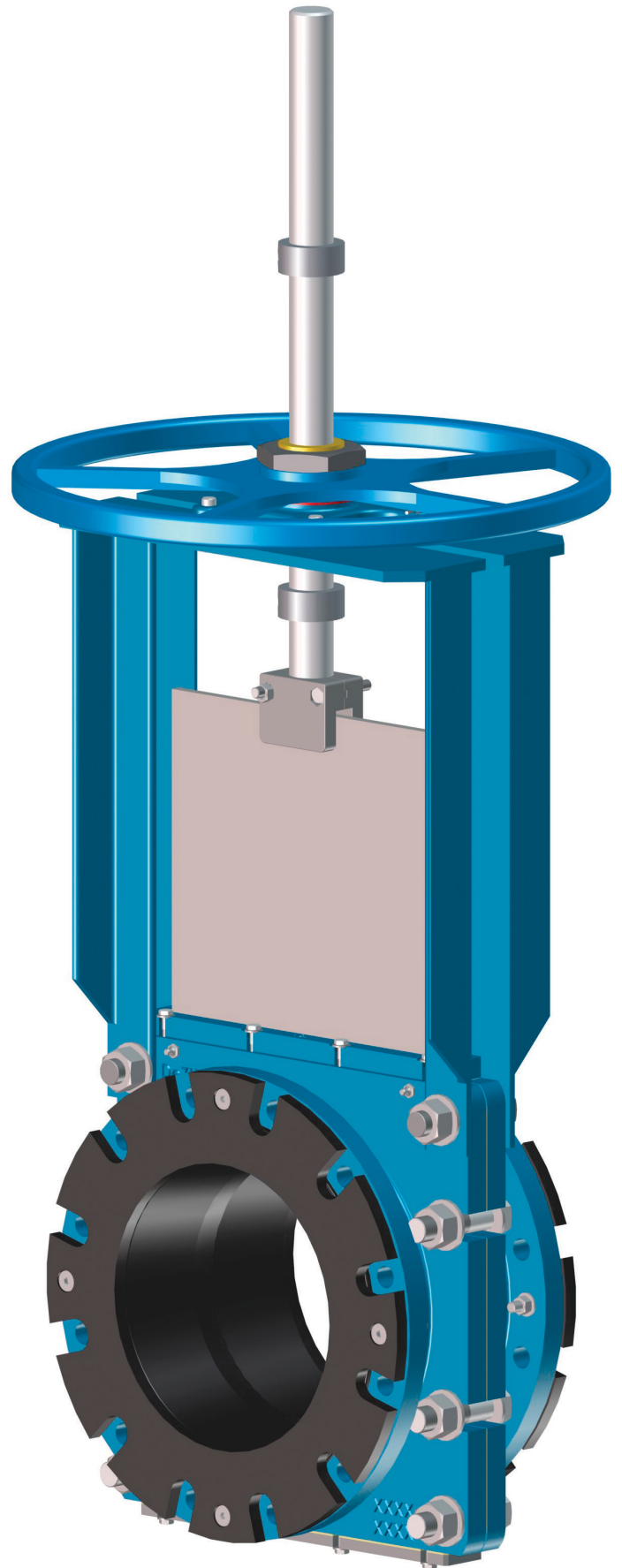

Packingless Design

The DeZURIK KSL-LA's compression-loaded sleeve design eliminates the need for conventional style packing. In the full open and closed positions, the sleeves seal to both downstream and atmosphere.

Open / Closed Position Lock-outs

The DeZURIK KSL-LA is available with optional open and closed position lock-outs. The lock-outs are designed to withstand the maximum operating forces of the actuator supplied on the valve.

Rugged Stainless Steel Gate

A durable gate resists damage and allows higher pressure drops. Gate material options include various stainless steels, heat-treated stainless steel and Hastelloy C. The gate is finish ground on both sides and edges to ensure long top seal and sleeve life.

To extend top seal and sleeve life, optional gate coatings are available that provide a lubrication-infused, non-stick surface that reduces the operating forces of the valve. A strong investment cast gate clip complements the KSL-LA's robust construction.

Stainless Steel Stem

All valves are furnished with a stainless steel stem as standard that provides extra corrosion resistance, easy operation, and a longer cycle life. On manually operated valves the stem has single-lead threads to minimize wear and reduce the operating torque requirements of the valve.

Top Seal with Integrated Plate

The DeZURIK KSL-LA has a top seal to prevent any discharge of process media from the top of the valve when the valve is stroked. The integrated plate design also centers, guides, and supports the gate, ensuring smooth operation.

Choice of Actuators

The DeZURIK KSL-LA Slurry Knife Gate Valve is offered with a choice of handwheel, chainwheel, bevel gear, pneumatic or hydraulic cylinder, or electric motor actuators. Custom Engineered Hydraulic Power Units are also available.

Corrosion Resistant Yoke Sleeve

A bronze yoke sleeve on manually operated valves provides corrosion resistance and assures easy operation. A grease fitting is provided to lubricate the stem thread and yoke sleeve.

Heavy-Duty Vertical Plane Superstructure

The standard actuator superstructure is available in carbon steel or stainless steel and is designed to stand up under the most difficult operating conditions. The vertical plane design allows for easy installation of accessories. For valves mounted in horizontal installations, strengthened superstructures are available.

Accessories

A wide variety of accessories are available including handwheel extensions, floorstands, stem covers and various cylinder actuator accessories such as filter regulators, speed controls and position indicating switches for customizing the valve/actuator package to meet specific application requirements.

Materials of Construction

Item	Description	Material
A1	Body	Ductile Iron, ASTM A395, Grade 65-45-12
A2	Gate	316 Stainless Steel, ASTM A240 Type 316
		17-4 PH Stainless Steel H900 Heat Treated, ASTM A564
		2205 Duplex Stainless Steel, ASTM A240 Type 2205 Duplex
		316 Stainless Steel, ASTM A240 Type 316 with a hardened nickel based non-stick coating
		17-4 PH Stainless Steel H900 Heat Treated, ASTM A564 with a hardened nickel based non-stick coating
A3	Sleeve	2205 Duplex Stainless Steel, ASTM A240 with a hardened nickel based non-stick coating
		NR - Natural Rubber to 177°F (81°C)
		HNBR - Hydrogenated Nitrile Butadiene to 300°F (150°C)
A4	Sleeve Retainer	EPDM - Terpolymer of Ethylene, Propylene & a Diene, to 250°F (120°C)
		NR - Natural Rubber to 177°F (81°C)
		HNBR - Hydrogenated Nitrile Butadiene to 300°F (150°C)
A5	Body Gasket	Duralon 8500
A6	Top Seal	EPDM - Terpolymer of Ethylene, Propylene & a Diene, to 250°F (120°C)
A7	Drain Gasket	Hydrogenated Nitrile Butadiene to 300°F (150°C)
A8	Drain Plate	Duralon 8500 (DP Option)
A9	Grease Fitting	Carbon Steel, ASTM A36 (DP Option)
A10	Screw	Steel
A11	Screw	Carbon Steel, Zinc Plated
A12	Washer	Carbon Steel, Zinc Plated
A13	Lockwasher	Carbon Steel, Zinc Plated
A14	Nut	Carbon Steel, Zinc Plated
A15	Screw	Carbon Steel, Zinc Plated (DP Option)
A16	Washer	Carbon Steel, Zinc Plated (DP Option)
A17	Screw	Carbon Steel, Zinc Plated
A18	Washer	Carbon Steel, Zinc Plated
A19	Screw	Carbon Steel, Zinc Plated
A20	Nut	Carbon Steel, Zinc Plated

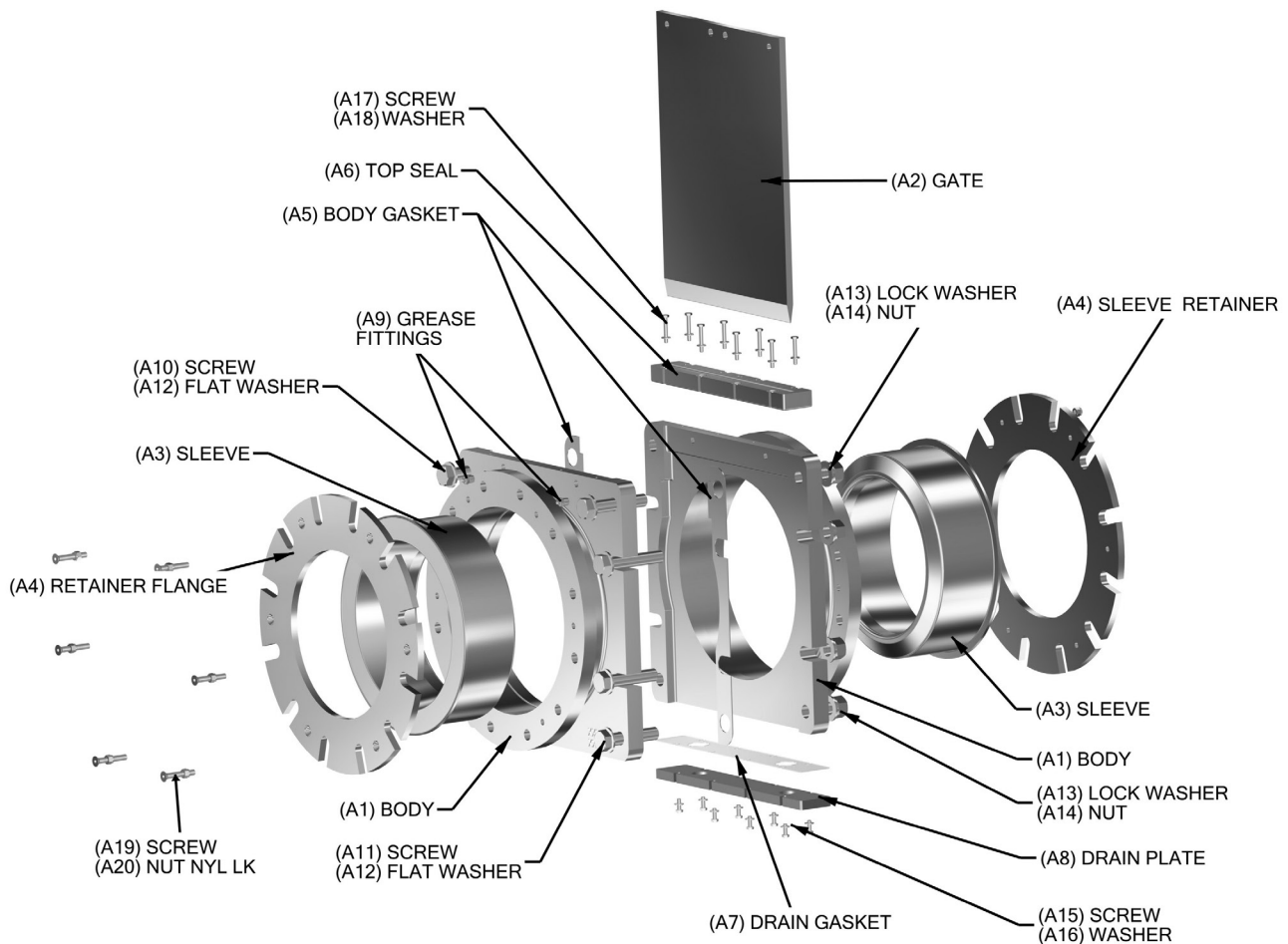

Valve Selection

Shut-Off Capabilities

2-24" (50-600mm)	Driptight
------------------	-----------

NOTE: Leakage expected during actuation

Pressure Ratings (Ambient Temperatures)

Valve Size	
2-24" (50-600mm)	100 psi C.W.P. 690kPa

Higher pressures available on application

Applicable Standards

DeZURIK KSL-LA Knife Gate Valves are designed and/or tested to meet the following standards:	
ASME B16.5/150	ASME B16.5 Class 150 Flange Drilling
DIN 10	Metric 10 bar Flange Drilling
DIN 16	Metric 16 bar Flange Drilling
AS2129 Table D	Australian Table D Flange Drilling
AS2129 Table E	Australian Table E Flange Drilling
SANS 1123-1000	South African 1000 kPa Flange Drilling
SANS 1123-1600	South African 1600 kPa Flange Drilling

Flow Parameters

Valve Size	Cv* Kv* 100% Open	K** (resistance)	Port Area (in ² /cm ²)
2" 50mm	193 167	0.16	2.0 13
3" 80mm	434 376	0.16	4.6 29
4" 100mm	829 717	0.16	8.7 56
5" 125mm	1500 1300	0.16	15.8 102
6" 150mm	2160 1870	0.16	22.7 146
8" 200mm	3540 3060	0.16	37.2 240
10" 250mm	6140 5310	0.16	64.5 416
12" 300mm	8640 7470	0.16	90.8 586
14" 350mm	11700 10100	0.16	123 792
16" 400mm	14700 12700	0.16	154 993
18" 450mm	16600 14400	0.16	174 1122
20" 500mm	20500 17700	0.16	215 1390
24" 600mm	33600 29100	0.16	353 2275

*Cv = Flow in GPM of water at 1 psi pressure drop.
Kv = Flow in m³/hr. of water at 100 kPa pressure drop.
** K = The resistance coefficient of the valve.
The constant (K) can be used to determine the equivalent length of pipe.

$$L = \frac{K \times D}{f} \text{ Where}$$

- L = Equivalent length of pipe in feet
- K = Resistance coefficient
- D = Pipe diameter in feet
- f = Friction factor, related to type of pipe

Valve Weights

Valve Size	Basic Valve	With Handwheel	With Chainwheel	With Bevel Gear Handwheel		With Bevel Gear Chainwheel		Pneumatic Cylinder	Hydraulic Cylinder
				Standard Mounting	90° Mounting	Standard Mounting	90° Mounting		
2" 50mm	31 14	62 28	74 33	110 50		118 53		69 31	51 23
3" 80mm	45 20	76 35	88 40	124 56		132 60		83 38	65 30
4" 100mm	55 25	113 51	121 55	158 72		166 75		117 53	101 46
5" 125mm	71 32	121 55	130 59	168 76		175 80	222 101	136 62	109 50
6" 150mm	81 37	131 60	140 64	178 81		185 84	232 105	146 66	119 54
8" 200mm	148 67	212 96	228 104	254 115		261 119	307 140	220 100	200 91
10" 250mm	151 69	226 103	242 110	267 121		288 131	334 152	228 104	235 107
12" 300mm	271 123	N/A	N/A	460 209		479 218	525 239	509 231	399 181
14" 350mm	338 154	N/A	N/A	496 225	543 247	516 235	563 256	511 232	452 205
16" 400mm	472 215	N/A	N/A	628 285	674 306	649 295	695 316	704 320	579 263
18" 450mm	600 273	N/A	N/A	860 391	975 443	880 400	995 452	846 385	710 323
20" 500mm	885 402	N/A	N/A	1172 533	1287 585	1193 542	1307 594	1445 657	1090 495
24" 600mm	1155 525	N/A	N/A	1499 681	1611 731	1519 690	1632 741	1704 775	1415 643

Ordering

To order, simply complete the valve order code from information shown. An ordering example is shown for your reference.

Valve Style

Give valve style code as follows:

KSL = Slurry Knife Gate Valve

Valve Size

Give valve size code as follows:

2	=	2"	(50mm)	12	=	12"	(300mm)
3	=	3"	(80mm)	14	=	14"	(350mm)
4	=	4"	(100mm)	16	=	16"	(400mm)
5	=	5"	(125mm)	18	=	18"	(450mm)
6	=	6"	(150mm)	20	=	20"	(500mm)
8	=	8"	(200mm)	24	=	24"	(600mm)
10	=	10"	(250mm)				

Sizes 22" (550mm) and 26-60" (650-1500mm) are available on application. Contact DeZURIK for more information.

Body Style

Give body style code as follows:

LA = Long Body Style

End Connection

Give end connection code as follows:

F1	=	ASME B16.5 Class 150 UNC Tapping for Threads
F110	=	ISO 7005/PN10 Drilling
F116	=	ISO 7005/PN16 Drilling
F1DA	=	AS2129 Table D Drilling
F1EA	=	AS2129 Table E Drilling
F1S10	=	SANS1123-1000
F1S16	=	SANS1123-1600

Body Material

Give body material code as follows:

DI = Ductile Iron

Other body materials are available on application

Top Seal

Give top seal material code as follows:

EPDM = Terpolymer of Ethylene, Propylene & a Diene, to 250°F (120°C)
HNBR = Hydrogenated Nitrile Butadiene to 300°F (150°C)

Gate Material

Give gate material code as follows:

S2 = 316 Stainless Steel
S5 = 17-4 Stainless Steel H900 Heat Treated
S10 = 2205 Duplex Stainless Steel
S2C = 316 Stainless Steel with a hardened nickel-based, nonstick coating
S5C = 17-4PH Stainless Steel H900 Heat Treated with a hardened nickel-based, nonstick coating
S10C = 2205 Duplex Stainless Steel with a hardened nickel-based, nonstick coating

Sleeve Material

Give sleeve material code as follows:

NR = Natural Rubber to 177°F (81°C)
EPDM = Terpolymer of Ethylene, Propylene & a Diene, to 250°F (120°C)
HNBR = Hydrogenated Nitrile Butadiene to 300°F (150°C)

Options

Give option code as follows:

— = Paint Options (Contact DeZURIK)
CRT = Certified Physical and Chemical Test Reports (body & gate only)
CMC = Certificate of Material Conformance
DP = Drain Plate
FLS = Sleeve Retainer Flange Seals, 2-8" (50-200mm) valves only.
Sleeve Retainer Flange Seals are included as standard on 10" (250mm) and larger valves

Ordering Example:

KSL,6,LA,F1,DI,EPDM,S2,NR,DP*actuator

Manual Actuators

Handwheel and Chainwheel Actuators

All 2-10" (50-250mm) valves can be furnished with handwheel or chainwheel actuators. To order, add the appropriate order code to the basic valve order code. Refer to information on bevel gear actuators when pressures exceed limits shown. Actuator sizing is for slurries and liquids; contact DeZURIK for sizing on dry materials applications. Order chain for chainwheel actuators as a separate item.

Handwheel Actuator

Valve Size	Order Code	Maximum Shutoff Pressure Differential psi/kPa
	Carbon Steel (CS) Yoke	
2" 50mm	MN-HD12-CS	100 690
3" 80mm	MN-HD12-CS	100 690
4" 100mm	MN-HD12-CS	100 690
5" 125mm	MN-HD12-CS	100 690
6" 150mm	MN-HD16-CS	100 690
8" 200mm	MN-HD20-CS	100 690
10" 250mm	MN-HD20-CS	50 345

Chainwheel Actuator

Valve Size	Order Code	Maximum Shutoff Pressure Differential psi/kPa
	Carbon Steel (CS) Yoke	
2" 50mm	MN-CW12-CS	100 690
3" 80mm	MN-CW12-CS	100 690
4" 100mm	MN-CW12-CS	100 690
5" 125mm	MN-CW12-CS	100 690
6" 150mm	MN-CW20-CS	100 690
8" 200mm	MN-CW20-CS	100 690
10" 250mm	MN-CW20-CS	50 345

Ordering Example:

KSL,6,LA,F1,DI,EPDM,S2,NR,DP*MN-HD16-CS

Bevel Gear Actuators

Bevel gear actuators are available on 3-24" (80-600mm) valves with handwheel or chainwheel actuators. Bevel gear actuators provide vertical mounting of the handwheel or chainwheel, or can be used where space limitations prohibit the use of a standard handwheel or chainwheel. A mechanical advantage makes large valve operation easier and faster. Actuator sizing is for slurries and liquids; contact DeZURIK for sizing on dry materials applications.

Bevel Gear Handwheel Actuator

Valve Size	Order Code	Maximum Shutoff Pressure Differential psi/kPa
	Carbon Steel (CS) Yoke	
3" 80mm	MNB-HD12-CS	100 690
4" 100mm	MNB-HD12-CS	100 690
5" 125mm	MNB-HD12-CS	100 690
6" 150mm	MNB-HD12-CS	100 690
8" 200mm	MNB-HD12-CS	100 690
10" 250mm	MNB-HD24-CS	100 690
12" 300mm	MNB-HD24-CS	100 690
14" 350mm	MNB-HD24-CS	100 690
16" 400mm	MNB-HD24-CS	100 690
18" 450mm	MNB-HD24-CS	100 690
20" 500mm	MNB-HD24-CS	100 690
24" 600mm	MNB-HD24-CS	100 690

Bevel Gear Chainwheel Actuator

Valve Size	Order Code	Maximum Shutoff Pressure Differential psi/kPa
	Carbon Steel (CS) Yoke	
3" 80mm	MNB-CW12-CS	100 690
4" 100mm	MNB-CW12-CS	100 690
5" 125mm	MNB-CW12-CS	100 690
6" 150mm	MNB-CW12-CS	100 690
8" 200mm	MNB-CW12-CS	100 690
10" 250mm	MNB-CW20-CS	100 690
12" 300mm	MNB-CW20-CS	100 690
14" 350mm	MNB-CW20-CS	100 690
16" 400mm	MNB-CW20-CS	100 690
18" 450mm	MNB-CW20-CS	100 690
20" 500mm	MNB-CW20-CS	100 690
24" 600mm	MNB-CW20-CS	100 690

Ordering Example:

KSL,6,LA,F1,DI,EPDM,S2,NR,DP*MNB-HD12-CS

Manual Actuator Accessories

Chain for Chainwheel Actuators

Order as a separate item by giving the correct code and specify required length of chain as second line information. One closing link is supplied with the chainwheel actuator.

Order Code	Description
ACC*CN102	Steel, Zinc Plated 3/16
ACC*CN103	Galvanized 3/16
ACC*CN106	316 Stainless Steel 3/16

Ordering Example:

ACC*CN102

Chain 12 feet long (366cm)

Full-Force Lockout Device

Lockouts for open and closed position are available on all sizes of handwheel, bevel gear handwheel and cylinder actuated valves. Lockouts are designed to hold the full actuator force, plus a safety factor. To order, add a comma and the order code "LK" after the actuator code.

Ordering Example:

KSL,6,LA,F1,DI,EPDM,S2,NR,DP*MNB-HD12-CS,LK

Pneumatic Cylinder Actuators

DeZURIK double-acting pneumatic cylinder actuators are available for on/off service. Supply pressure is 60 or 80 psi (410 or 550 kPa). To order, add the proper code from the table to the valve order code. Actuator sizing is for slurries and liquids; contact DeZURIK for sizing on dry materials applications.

60 psi (410 kPa) Air Supply

Valve Size	Order Code	Maximum Shutoff Pressure Differential psi/kPa
	Carbon Steel (CS) Yoke	
2" 50mm	CY-PC4-CS	100 690
3" 80mm	CY-PC6-CS	100 690
4" 100mm	CY-PC6-CS	100 690
5" 125mm	CY-PC6-CS	100 690
6" 150mm	CY-PC6-CS	100 690
8" 200mm	CY-PC8-CS	100 690
10" 250mm	CY-PC10-CS	100 690
12" 300mm	CY-PC12-CS	100 690
14" 350mm	CY-PC12-CS	100 690
16" 400mm	CY-PC14-CS	100 690
18" 450mm	CY-PC14-CS	100 690
20" 500mm	CY-PC16-CS	100 690
24" 600mm	CY-PC16-CS	100 690

80 psi (550 kPa) Air Supply

Valve Size	Order Code	Maximum Shutoff Pressure Differential psi/kPa
	Carbon Steel (CS) Yoke	
2" 50mm	CY-PC4-CS	100 690
3" 80mm	CY-PC6-CS	100 690
4" 100mm	CY-PC6-CS	100 690
5" 125mm	CY-PC6-CS	100 690
6" 150mm	CY-PC6-CS	100 690
8" 200mm	CY-PC8-CS	100 690
10" 250mm	CY-PC10-CS	100 690
12" 300mm	CY-PC12-CS	100 690
14" 350mm	CY-PC12-CS	100 690
16" 400mm	CY-PC14-CS	100 690
18" 450mm	CY-PC14-CS	100 690
20" 500mm	CY-PC16-CS	100 690
24" 600mm	CY-PC16-CS	100 690

Hydraulic Cylinder Actuators

Double-acting hydraulic cylinders are available for on/off service. All actuators are sized to the full pressure rating of the valve. Actuator sizing is for slurries and liquids; contact DeZURIK for sizing on dry materials applications.

Valve Size	Order Code	Fluid Supply Pressure (psi/kPa)	Maximum Shutoff Pressure Differential (psi/kPa)
	Carbon Steel (CS) Yoke		
2" 50mm	CY-HC1.5-CS	1200 8280	100 690
3" 80mm	CY-HC1.5-CS	1200 8280	100 690
4" 100mm	CY-HC1.5-CS	1200 8280	100 690
5" 125mm	CY-HC2-CS	1200 8280	100 690
6" 150mm	CY-HC2-CS	1200 8280	100 690
8" 200mm	CY-HC2-CS	1200 8280	100 690
10" 250mm	CY-HC3.25-CS	550 3795	100 690
12" 300mm	CY-HC3.25-CS	550 3795	100 690
14" 350mm	CY-HC4-CS	550 3795	100 690
16" 400mm	CY-HC4-CS	550 3795	100 690
18" 450mm	CY-HC4-CS	550 3795	100 690
20" 500mm	CY-HC5-CS	550 3795	100 690
24" 600mm	CY-HC5-CS	550 3795	100 690

Note: The maximum hydraulic pressure rating for hydraulic cylinders by size is as follows:

- HC1.5 is 2000 psi
- HC2 is 2000 psi
- HC3.25 is 1000 psi
- HC4 is 800 psi
- HC5 is 950 psi

Cylinder Actuator Accessories

Filter Regulator

The DeZURIK Filter Regulator is designed to provide clean, accurate pressure to cylinder actuators.

Four-Way Solenoid Valve

Solenoid valves may be ordered mounted and piped as part of a complete valve and cylinder actuator assembly or as a separate item.

Speed Control Valves

Speed Control Valves are available for controlling valve opening or closing speed with cylinder actuators.

Position Indicating Switches

Mechanical or Proximity Position Indicating Switches are available for use on cylinder actuators. One switch can be set to indicate open or closed position. Two switches will automatically be set to indicate full open and full closed positions.

Stem Cover Bellows

To protect valve stem from environmental debris, the Stem Cover Bellows may be ordered as part of a complete valve and actuator assembly.

Ordering Example:

KSL,6,LA,F1,DI,EPDM,S2,NR,DP*CY-PC6-CS,SCB

Full-Force Lockout Device

Lockouts for open and closed position are available on all sizes for cylinder actuated valves. Lockouts are designed to hold the full actuator force, plus a safety factor. To order, add a comma and the order code "LK" after the actuator code.

Ordering Example:

KSL,6,LA,F1,DI,EPDM,S2,NR,DP*CY-PC6-CS,LK

Electric Motor Actuators

DeZURIK Knife Gate Valves can be furnished with electric motor actuators including Limitorque, Auma, Rotork, E.I.M. and others.

When ordering electric motor actuators, specify valve order code, shutoff pressure, service conditions (flowing media and installation direction); type of application (on/off); speed of operation; NEMA rating (4, 7, as per specification requirements.submersible, etc.); electrical characteristics (voltage and phase); actuator accessories and controls

Dimensions

Handwheel & Chainwheel

Valve Size	Dimensions				
	D	E* Installed	G Handwheel	G Chainwheel	K
2" 50mm	3.00 76	6.88 175	12.00 305	12.00 305	19.60 498
3" 80mm	3.75 95	6.88 175	12.00 305	12.00 305	20.98 533
4" 100mm	4.50 114	6.88 175	12.00 305	12.00 305	22.98 584
5" 125mm	5.00 127	7.00 178	12.00 305	12.00 305	28.85 733
6" 150mm	5.50 140	7.00 178	16.00 406	20.00 508	30.35 771
8" 200mm	6.75 171	7.25 184	20.00 508	20.00 508	35.23 895
10" 250mm	8.00 203	8.88 226	20.00 508	20.00 508	45.37 1152

* Retainer flanges are standard on 10" (250mm) and larger, and optional on 2-8" (50-200mm).
If retainer flanges are not required, deduct 1.00" (25mm). Allow an additional .25-.50" (6-13mm) for installation.

Inches
Millimeters

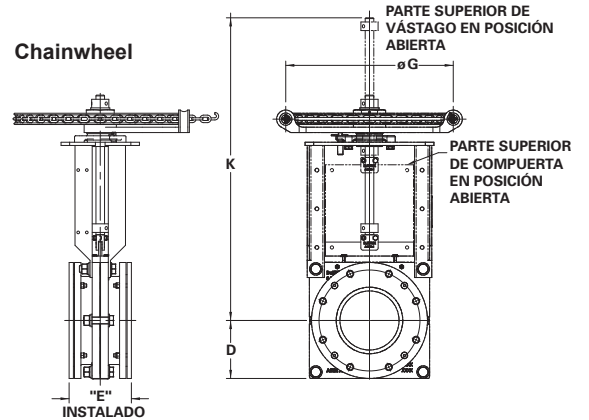
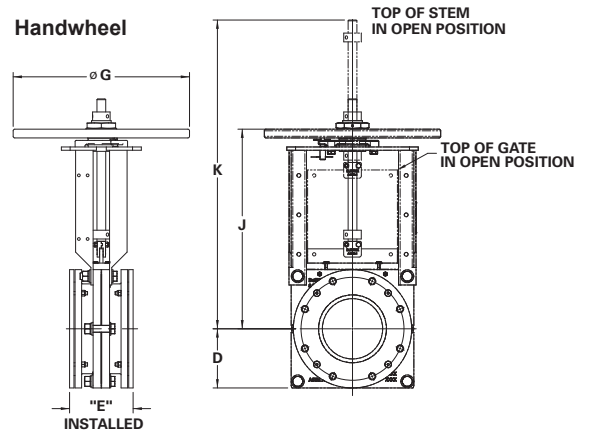

Bevel Gear Handwheel

Valve Size	Dimensions					
	D	E* Installed	G	H Standard Mounting	H 90 Degree Mounting	J
3" 80mm	3.75 95	6.88 175	12.00 305	10.12 257	10.12 257	23.45 596
4" 100mm	4.50 114	6.88 175	12.00 305	10.12 257	10.12 257	25.70 653
5" 125mm	5.00 127	7.00 178	12.00 305	10.12 257	10.12 257	30.38 772
6" 150mm	5.50 140	7.00 178	12.00 305	10.12 257	10.12 257	32.70 831
8" 200mm	6.75 171	7.25 184	12.00 305	10.12 257	10.12 257	39.07 992
10" 250mm	8.00 203	8.88 226	24.00 610	18.37 467	18.37 467	44.45 1129
12" 300mm	9.50 241	10.13 257	24.00 610	18.37 467	18.37 467	51.58 1310
14" 350mm	10.50 267	10.15 258	24.00 610	18.37 467	26.25 667	55.45 1408
16" 400mm	11.75 298	11.00 279	24.00 610	18.37 467	26.25 667	63.20 1605
18" 450mm	12.50 318	12.25 311	24.00 610	20.98 533	35.48 901	72.33 1837
20" 500mm	13.75 349	14.13 359	24.00 610	20.98 533	35.48 901	75.15 1909
24" 600mm	16.00 406	14.63 372	24.00 610	20.98 533	35.48 901	94.95 2412

* Retainer flanges are standard on 10" (250mm) and larger, and optional on 2-8" (50-200mm).
If retainer flanges are not required, deduct 1.00" (25mm). Allow an additional .25-.50" (6-13mm) for installation.

Inches
Millimeters

Standard Mounting

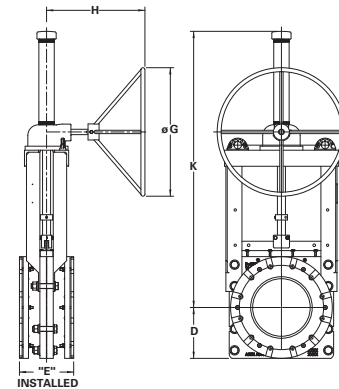

90 Degree Mounting

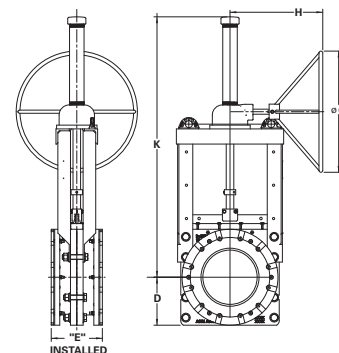

Dimensions

Bevel Gear Chainwheel

Valve Size	Dimensions					
	D	E* Installed	G	H Standard Mounting	H 90 Degree Mounting	K
3" 80mm	3.75 95	6.88 175	12.00 305	9.62 244	9.62 244	23.45 596
4" 100mm	4.50 114	6.88 175	12.00 305	9.62 244	9.62 244	25.70 653
5" 125mm	5.00 127	7.00 178	12.00 305	9.62 244	18.37 467	30.38 772
6" 150mm	5.50 140	7.00 178	12.00 305	9.62 244	18.37 467	32.70 831
8" 200mm	6.75 171	7.25 184	12.00 305	9.62 244	18.37 467	39.07 992
10" 250mm	8.00 203	8.88 226	20.00 508	9.62 244	18.37 467	44.45 1129
12" 300mm	9.50 241	10.13 257	20.00 508	9.62 244	18.37 467	51.58 1310
14" 350mm	10.50 267	10.15 258	20.00 508	9.62 244	18.37 467	55.45 1408
16" 400mm	11.75 298	11.00 279	20.00 508	9.62 244	18.37 467	63.20 1605
18" 450mm	12.50 318	12.25 311	20.00 508	12.23 311	26.27 667	72.33 1837
20" 500mm	13.75 349	14.13 359	20.00 508	12.23 311	26.27 667	75.15 1909
24" 600mm	16.00 406	14.63 372	20.00 508	12.23 311	26.27 667	94.95 2412

* Retainer flanges are standard on 10" (250mm) and larger, and optional on 2-8" (50-200mm).
If retainer flanges are not required, deduct 1.00" (25mm). Allow an additional .25-.50" (6-13mm) for installation.

Inches
Millimeters

Standard Mounting

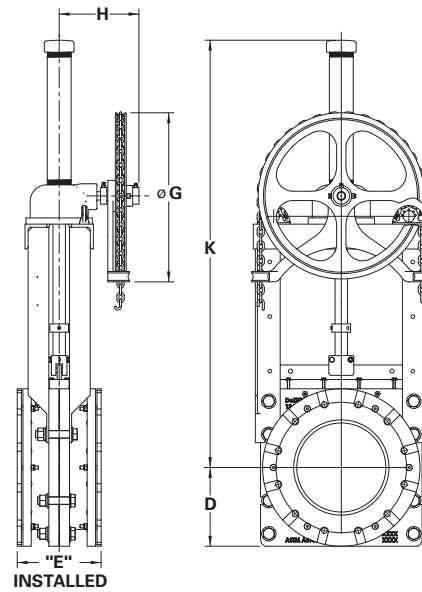

90 Degree Mounting

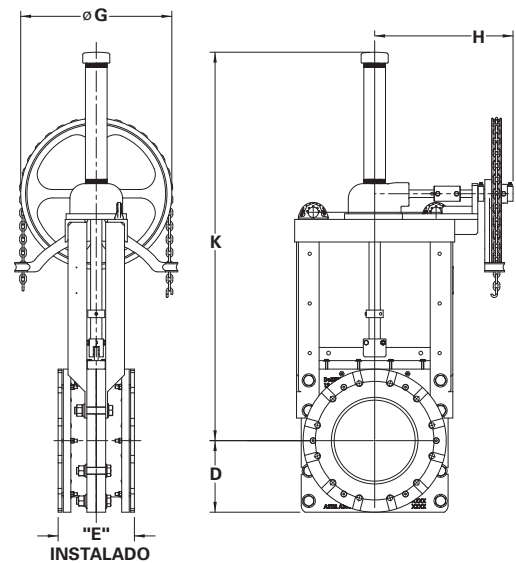

Dimensions

Pneumatic Cylinder

Valve Size	Dimensions			
	D	E* Installed	L	K
2"	3.00	6.88	7.88	23.83
50mm	76	175	200	605
3"	3.75	6.88	9.50	25.33
80mm	95	175	241	643
4"	4.50	6.88	11.00	27.20
100mm	114	175	279	691
5"	5.00	7.00	12.50	32.89
125mm	127	178	318	835
6"	5.50	7.00	13.50	35.20
150mm	140	178	343	894
8"	6.75	7.25	15.00	37.61
200mm	171	184	381	955
10"	8.00	8.88	18.00	37.68
250mm	203	226	457	957
12"	9.50	10.13	21.25	56.32
300mm	241	257	540	1431
14"	10.50	10.15	22.75	59.89
350mm	267	258	578	1521
16"	11.75	11.00	25.00	67.89
400mm	298	279	635	1724
18"	12.50	12.25	26.50	71.20
450mm	318	311	673	1808
20"	13.75	14.13	29.50	74.38
500mm	349	359	749	1889
24"	16.00	14.63	34.00	87.44
600mm	406	372	864	2221

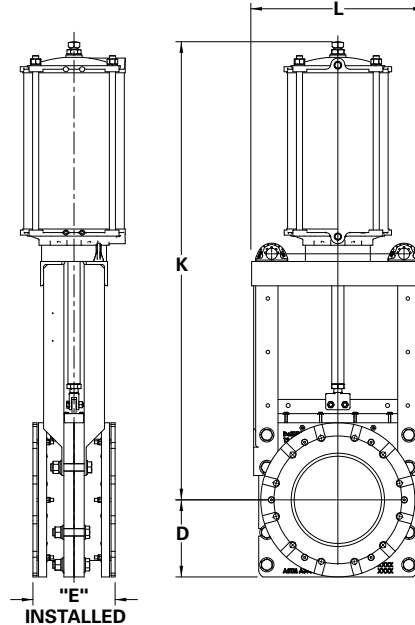

* Retainer flanges are standard on 10" (250mm) and larger, and optional on 2-8" (50-200mm). If retainer flanges are not required, deduct 1.00" (25mm). Allow an additional .25-.50" (6-13mm) for installation.

Inches
Millimeters

Hydraulic Cylinder

Valve Size	Dimensions			
	D	E* Installed	K	L
2"	3.00	6.88	20.50	7.88
50mm	76	175	521	200
3"	3.75	6.88	21.87	9.50
80mm	95	175	555	241
4"	4.50	6.88	24.25	11.00
100mm	114	175	616	279
5"	5.00	7.00	28.75	12.50
125mm	127	178	730	318
6"	5.50	7.00	31.31	13.50
150mm	140	178	795	343
8"	6.75	7.25	34.44	15.00
200mm	171	184	875	381
10"	8.00	8.88	42.63	18.00
250mm	203	226	1083	457
12"	9.50	10.13	47.57	21.25
300mm	241	257	1208	540
14"	10.50	10.15	53.38	22.75
350mm	267	258	1356	578
16"	11.75	11.00	59.26	25.00
400mm	298	279	1505	635
18"	12.50	12.25	66.31	26.50
450mm	318	311	1684	673
20"	13.75	14.13	71.69	29.50
500mm	349	359	1821	749
24"	16.00	14.63	84.81	34.00
600mm	406	372	2154	864

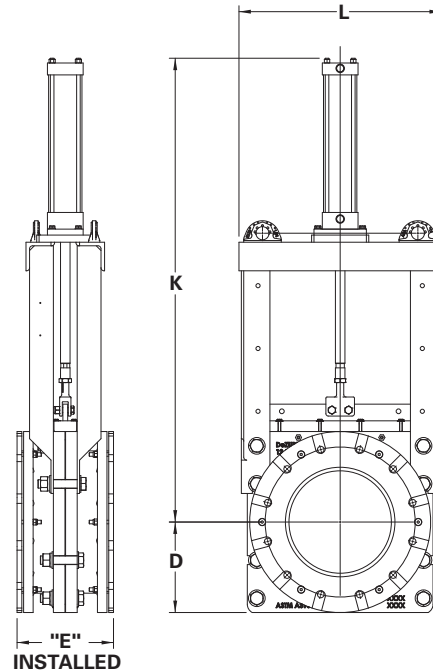

* Retainer flanges are standard on 10" (250mm) and larger, and optional on 2-8" (50-200mm). If retainer flanges are not required, deduct 1.00" (25mm). Allow an additional .25-.50" (6-13mm) for installation.

Inches
Millimeters



Need Knife Gate Valve pricing or support for your mining project? Contact us for more assistance.

Perth Branch

U2/41-45 Furnace Road
Welshpool WA 6106
Phone: +61 8 9353 2565
sales@thevalvecompany.com.au

Kalgoorlie Branch

2/69 Craig Road
West Kalgoorlie WA 6430
Phone: +61 8 9021 6668
sales@thevalvecompany.com.au

Brisbane Branch

U5/225 Queensport Road
North Murrarie QLD 4172
Phone: +61 7 3348 8636
sales@thevalvecompany.com.au

Bunbury Branch

Phone: +61 417 744 791
sales@thevalvecompany.com.au