

# DeZURIK KSV SEVERE SERVICE KNIFE GATE VALVES



## Design and Construction

The KSV Severe Service Knife Gate valve is specially designed to withstand high pressures and abrasive slurries – some of the toughest services in mining, (including oil sands processing), steel, power, chemical, municipal sludge, bio-fuels production, and paper industries.

Numerous features make this valve style ideal for isolation in high-pressure, high-density slurry lines. The rigid one-piece body, 100% diameter port, hard-faced gate and rotatable seat rings make this valve ideal for the most rigorous applications. KSV valves are pressure/temperature rated to ASME B16.34 Class 150 and 300 and are available in sizes 3-60" (80-1500mm).

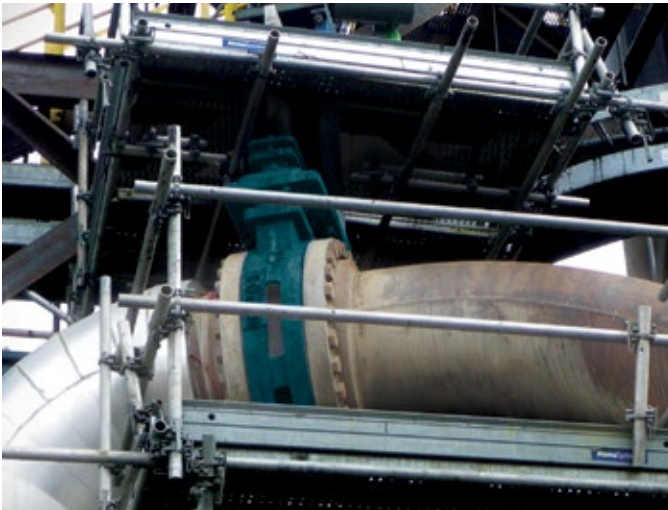

A Class 300 manual isolation KSV Knife Gate Valve handles course tailings at 350 psi at velocities of 13-14 ft. per second.

### Rigid, One-Piece Body

Severe Service Knife Gate Valve bodies in cast carbon steel, low temperature carbon steel, 316 Stainless Steel or 2205 Duplex Stainless Steel meet demanding performance requirements. Raised face body has drilled and tapped flanges in accordance with ASME B16.5 and B16.47. Purge-ports in the chest area as standard allow flushing of media from the valve interior. Lifting lugs cast into the packing chamber on all valve sizes (and additional cast and machined lugs in the body on larger sizes), make the KSV valve easy and safe to handle, install and maintain.

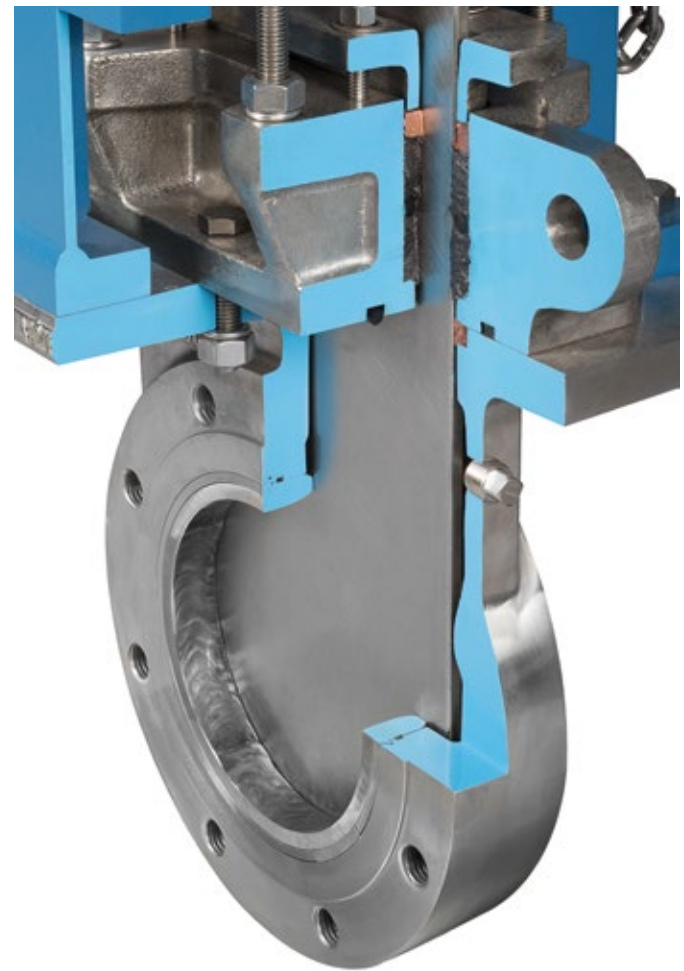

### Robust Packing System

The robust packing system includes six rows of a superior expanded PTFE Fiber with Graphite braided packing or PTFE packing, a resilient o-ring to provide live loading and two copper wire or nickel chromium alloy scraper rings. The KSV valves have a rounded gate edge, rounded packing chamber and an adjustable packing gland. This live-loaded, multi-ring packing system minimizes any external leakage, extends packing life and reduces maintenance. The scraper rings prevent process media from entering the packing chamber.

### 100% Port Area

The valve port inside diameter (ID) for ASME Class 150 valves matches standard pipe ID, and ASME Class 300 valves match extra-strong pipe ID per ASME B36.10. The KSV valve's 100% port area reduces turbulence, wear and pressure loss across the valve.

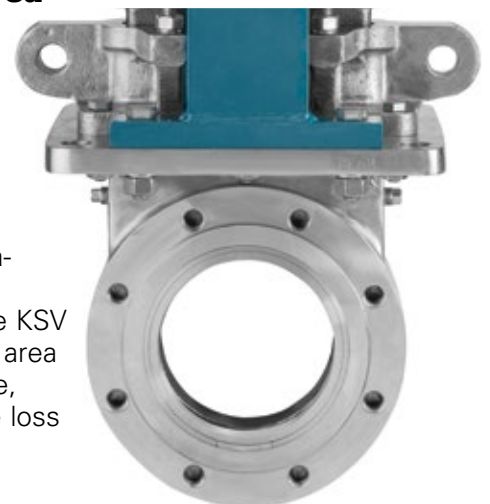



### **Hardened Gate**

The beveled, knife-like gate edge cuts through solids in the flow stream. Gates with a hardened nickel-based non-stick overlay and Tungsten bevel provide extra protection against abrasion.

### **Interchangeable, Rotatable, Configurable Hardened Seat Rings**

The KSV Severe Service Valves also feature a “dual wear ring design.” The hardened seat rings are identical so that they can be interchanged, rotated or replaced in the field to achieve maximum service life. In addition, the seats on the KSV valves can be provided with v-orifice, diamond port or square ports. In addition, Tungsten Carbide or Chrome Carbide overlays, in either 6mm or 13mm thicknesses, are available for high velocity applications.

### **Bi-Directional Shutoff**

The KSV valve’s mechanically retained seats provide bi-directional, dead-end service without a mating flange. Resilient seats provide bi-directional, drip-tight shutoff. Resilient seats are available in a variety of materials for services up to 400°F (204°C) as standard. Metal seated KSV valves conform to MSS SP-135 shutoff requirements for metal seated high pressure knife gate valves.

### **360° Gate Guiding & Support**

For maximum sealing performance, the seat rings work together to provide 360° guiding for the gate. The gate is fully supported and properly aligned within the machined packing chamber of the bolt-on packing box.



## **Full-Force Lockout System**

The KSV lockout system is designed to hold the full actuator force, plus a safety factor. This ultimate lockout system is available on either manual or powered actuators.

## **Actuator & Accessory Options**

As standard, valves are available with Bevel Gear Handwheel Actuators or Hydraulic Cylinder Actuators, with other actuators available on application. A full complement of accessories is also available.

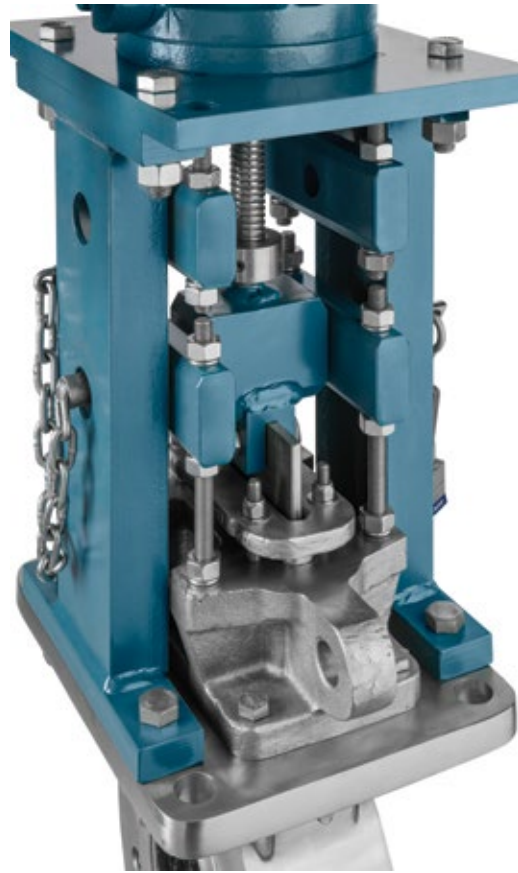

# Materials of Construction

## Class 150/300 Bonnetless

Item	Description	Material
A1	Body	Carbon Steel, ASTM A216 WCB
		2205 Duplex Stainless Steel, ASTM 351 CD3MN
		316 Stainless Steel, ASTM A351 CF8M
		Low Temperature Carbon Steel, ASTM A352 LCC
A2	Seat Ring (Base Material)	Carbon Steel
		316 Stainless Steel
		Hardened 17-4 PH Stainless Steel RC43
		White Iron Solid, ASTM A532, Class I-A
	Seat Ring (Coating Material)	Abrasion Resistant Cast Iron per ASTM A532, Class II-B
		No Coating
A3	O-Ring	Cobalt Chromium Alloy
		Chrome Carbide
		Tungsten Carbide
		NBR - Acrylonitrile-Butadiene to 180°F (83°C)
		CR - Chloroprene to 180°F (83°C)
		HNBR - Hydrogenated Nitrile to 302°F (150°C)
A4	Gate	FKM - Fluoro Rubber to 400°F (204°C)
		EPDM - Terpolymer of Ethylene Propylene and a Diene to 250°F (122°C)
		VGF - Fluorinated Hydro Carbon Fluoro Rubber to 400°F (204°C)
		2205 Duplex Stainless Steel, CD7/MCUN
		Hardened 400 Series Stainless Steel RC43, ASTM A240
		Hardened 17-4 Stainless Steel H900
		Hardened 17-4 Stainless Steel H900 with a hardened nickel-based, nonstick coating
		Hardened 17-4 Stainless Steel H900 with Tungsten Bevel
		Hardened 17-4 Stainless Steel H900 with Tungsten Bevel, and a hardened nickel-based, nonstick coating
		Carbon Steel Hardened RC43, with a hardened nickel-based, nonstick coating
A5	Screw	Abrasion Resistant, with a hardened nickel-based, nonstick coating
		Carbon Steel Zinc Plated
A6	Lockwasher	316 Stainless Steel
		Carbon Steel Zinc Plated
A7	Nut	316 Stainless Steel
		Carbon Steel Zinc Plated
A8	Packing Chamber	Same as body material
A9	O-Ring	NBR - Acrylonitrile-Butadiene to 180°F (83°C)
		CR - Chloroprene to 180°F (83°C)
		HNBR - Hydrogenated Nitrile to 302°F (150°C)
		FKM - Fluoro Rubber to 400°F (204°C)
		EPDM - Terpolymer of Ethylene Propylene and a Diene to 250°F (122°C)
A10	Packing	VGF - Fluorinated Hydro Carbon Fluoro Rubber to 400°F (204°C)
		Expanded PTFE Fiber with Graphite to 450°F (232°C)
A11	Scraper Ring	PTFE to 450°F (232°C)
		Braided Copper
A12	O-Ring	Nickel-Chromium alloy
		NBR - Acrylonitrile-Butadiene to 180°F (83°C)
		CR - Chloroprene to 180°F (83°C)
		HNBR - Hydrogenated Nitrile to 302°F (150°C)
		FKM - Fluoro Rubber to 400°F (204°C)
A13	Packing Gland	EPDM - Terpolymer of Ethylene Propylene and a Diene to 250°F (122°C)
		VGF - Fluorinated Hydro Carbon Fluoro Rubber to 400°F (204°C)
A14	Stud	Same as body material
		Carbon Steel Zinc Plated
A15	Nut	304 Stainless Steel
		Carbon Steel Zinc Plated
A16	Lockwasher	304 Stainless Steel
		Carbon Steel Zinc Plated
A17	Pipe Plug	304 Stainless Steel
		Carbon Steel Zinc Plated
A18	Resilient Seat	NBR - Acrylonitrile - Butadiene to 180°F (83°C)
		CR - Chloroprene to 180°F (83°C)
		HNBR - Hydrogenated Nitrile to 302°F (150°C)
		FKM - Fluoro Rubber to 400°F (204°C)
		EPDM - Terpolymer of Ethylene Propylene and a Diene to 250°F (122°C)
A19	Retaining Ring	VGF - Fluorinated Hydro Carbon Fluoro Rubber to 400°F (204°C)
A20	Keystone	Carbon Steel

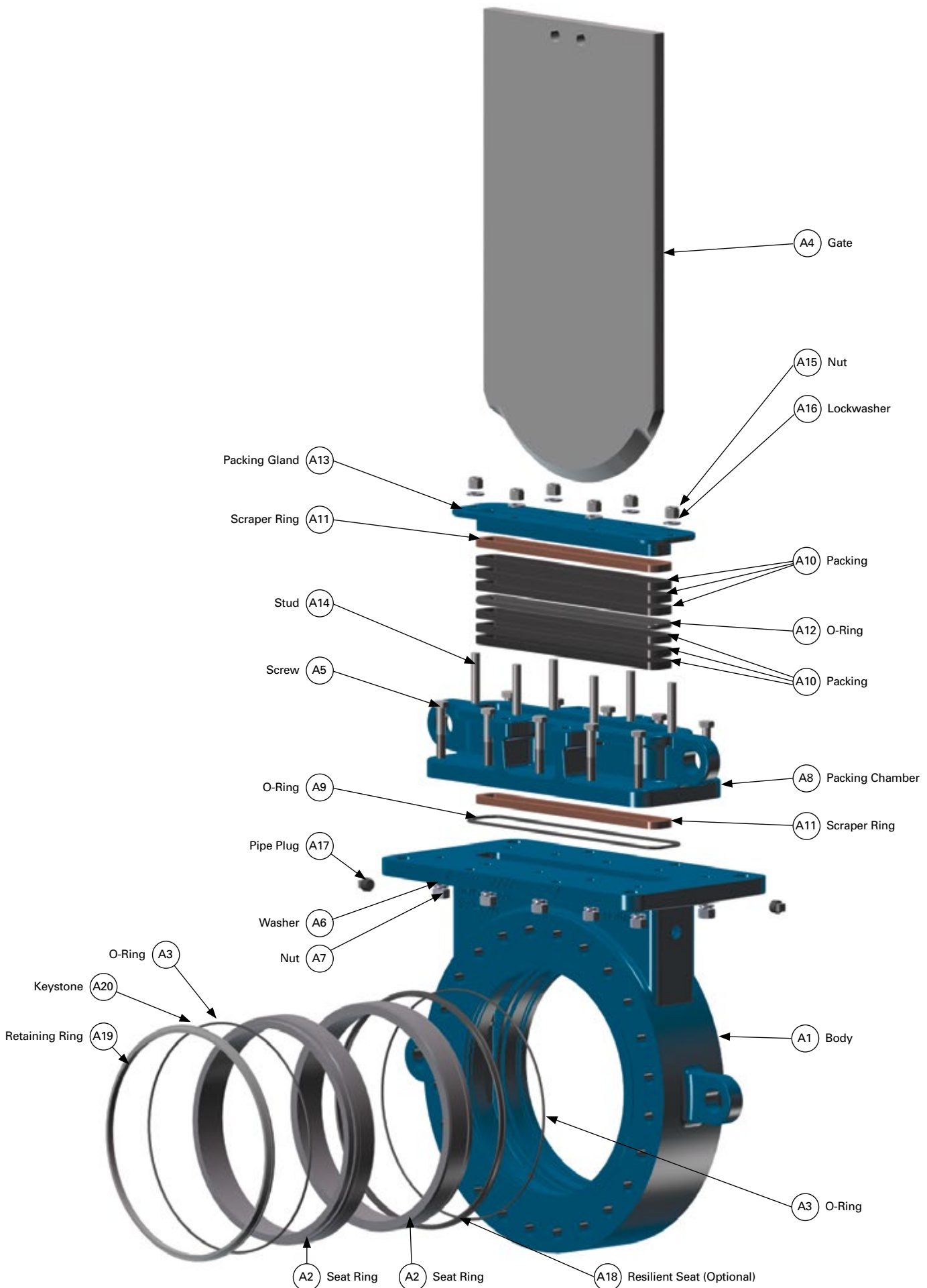

**Class 150/300 Bonnetless**

# Materials of Construction

## Class 150/300 Bonneted

Item	Description	Material
A8	Bonnet	Same as body material
A9	O-Ring	NBR - Acrylonitrile - Butadiene to 180°F (83°C)
		CR - Chloroprene to 180°F (83°C)
		HNBR - Hydrogenated Nitrile to 302°F (150°C)
		FKM - Fluoro Rubber to 400°F (204°C)
		EPDM - Terpolymer of Ethylene Propylene and a Diene to 250°F (122°C)
		VGF - Fluorinated Hydro Carbon to 400°F (204°C)
A10	Rod Seal	Braided Copper
		Nickel Chromium Alloy
A11	Washer	304 Stainless Steel
A12	Seal	Urethane/Acrylonitrile-Butadiene to 180°F (83°C)
A13	Bearing Sleeve	Bronze
A14	Bearing Carrier	Carbon Steel
A15	O-Ring	NBR - Acrylonitrile - Butadiene to 180°F (83°C)
		CR - Chloroprene to 180°F (83°C)
		HNBR - Hydrogenated Nitrile to 302°F (150°C)
		FKM - Fluoro Rubber to 400°F (204°C)
		EPDM - Terpolymer of Ethylene Propylene and a Diene to 250°F (122°C)
		VGF - Fluorinated Hydro Carbon Fluoro Rubber to 400°F (204°C)
A16	Seal Block	Carbon Steel
		2205 Duplex Stainless Steel
		316 Stainless Steel
A17	Pipe Plug	Carbon Steel Zinc Plated
		304 Stainless Steel
A21	Stem	203EZ Stainless Steel
		2205 Duplex Stainless Steel
A22	Jam Nut	Carbon Steel Zinc Plated
		316 Stainless Steel
A23	Clip Insert	203EZ Stainless Steel
		2205 Duplex Stainless Steel
A24	Retainer	Carbon Steel
		2205 Duplex Stainless Steel
		316 Stainless Steel
A25	Screw	Carbon Steel Zinc Plated
		316 Stainless Steel
A26	Gate Pin	304 Stainless Steel

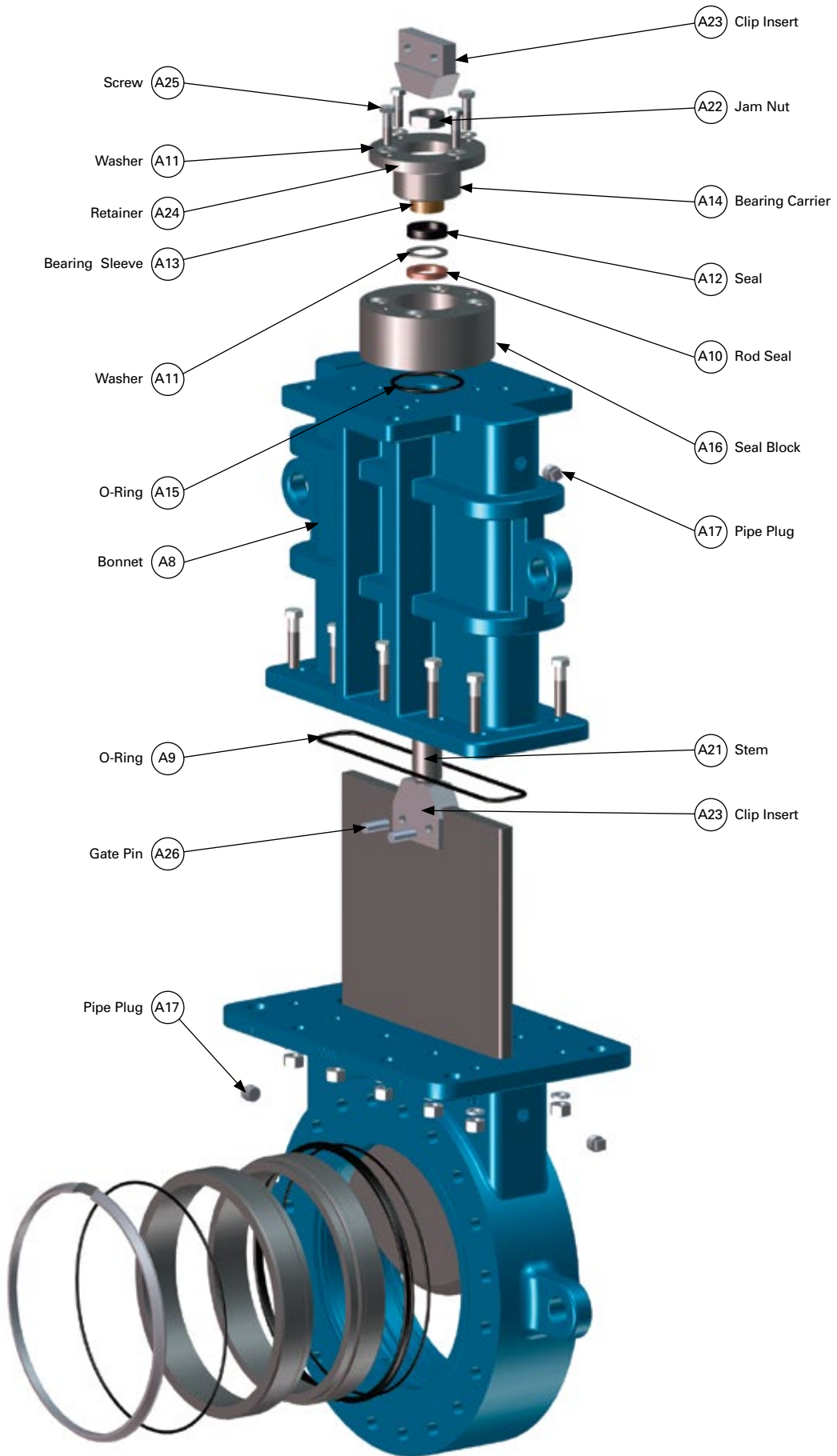

**Class 150/300 Bonneted**



# Valve Selection

## Applicable Standards

DeZURIK KSV Knife Gate Valves are designed and/or tested to meet the following standards:	
ASME B16.34	Valves-Flanged, Threaded and Welding End. All KSV Knife Gate Valves comply with requirements of this standard.
MSS SP-135	High Pressure Knife Gate Valves. Metal Seated Valves.
ASME B16.5 2-24" (50-600mm)	Carbon Steel Flanges and Flanged Fittings, ASME 150 or 300. Conforms to Related Dimensions.
ASME 16.47 26-60" (650-1525mm)	Large diameter Steel Flanges. Series A. Conforms to related dimensions.
API 598	Soft Seated Valves Meet the Procedure and Duration Requirement of this Standard.
International Standards	Conforms to flanged bolt guides: DIN 10, 16, 25, 40; ISO 7005/PN10, PN16, PN25, PN40; BS 4504/PN10; and AS2129 Tables D, E or F; SANS 1123-1000, 1600, 2500 or 4000.
ASME B36.10	Welded Seamless Wrought Steel Pipe. Port diameters match pipe diameters.

## Flow Parameters Class 150

Valve Size	Cv* Kv* 100% Open	K Factor** (resistance)	Port Area (in <sup>2</sup> /cm <sup>2</sup> )
3"	665	0.120	7
80mm	576		45
4"	1199	0.120	13
100mm	1038		84
6"	2697	0.120	28
150mm	2334		181
8"	4794	0.112	50
200mm	4149		323
10"	7491	0.112	79
250mm	6483		510
12"	10787	0.104	113
300mm	9338		729
14"	13152	0.104	138
350mm	11383		890
16"	17421	0.104	183
400mm	15078		1181
18"	22290	0.096	234
450mm	19292		1510
20"	27759	0.096	291
500mm	24025		1877
22"	33864	0.096	355
550mm	29314		2290
24"	40494	0.096	425
600mm	35053		2742
26"	45790	0.096	501
650mm	35047		3232
28"	53332	0.096	583
700mm	46166		3761
30"	64090	0.096	672
750mm	55438		4335
32"	70138	0.096	767
800mm	60704		4948
36"	93080	0.096	976
900mm	80560		6297
42"	125987	0.096	1320
1100mm	108973		8516
48"	129337	0.096	1735
1200mm	111960		11194
54"		Contact DeZURIK	
1400mm			
60"			
1500mm			

## Shut-Off Capabilities

Resilient Seats	Leak tight/drip tight Bidirectional
Metal Seats	Meet MSS SP-135 with valve installed in preferred direction

## Pressure Ratings (100°F (38°C))

Duplex Stainless Steel and Carbon Steel, Class 150	285 psi (1960 kPa)
Duplex Stainless Steel and Carbon Steel, Class 300	740 psi (5100 kPa)
316 Stainless Steel, Class 150	275 psi (1890 kPa)
316 Stainless Steel, Class 300	720 psi (4960 kPa)

## Class 300

Valve Size	Cv* Kv* 100% Open	K Factor** (resistance)	Port Area (in <sup>2</sup> /cm <sup>2</sup> )
3"	627	0.120	6.6
80mm	543		43
4"	1015	0.120	11
100mm	879		71
6"	2504	0.120	26
150mm	2168		168
8"	3643	0.112	38
200mm	3154		245
10"	6069	0.112	64
250mm	5254		413
12"	9069	0.104	95
300mm	7851		613
14"	12675	0.104	133
350mm	10972		858
16"	16850	0.104	177
400mm	14586		1142
18"	21623	0.096	227
450mm	18718		1465
20"	27091	0.096	284
500mm	23451		1832
22"	33005	0.096	346
550mm	28571		2232
24"	39541	0.096	415
600mm	34228		2677
26"	44876	0.096	491
650mm	38846		3167
28"	52417	0.096	573
700mm	38847		3697
30"	63041	0.096	661
750mm	54571		4265
32"	69041	0.096	755
800mm	59720		4811
36"	92222	0.096	967
900mm	78831		6206
42"		Contact DeZURIK	
1100mm			
48"			
1200mm			
54"			
1400mm			
60"			
1500mm			

\*Cv = Flow in GPM of water at 1 psi pressure drop.  
Kv = Flow in m<sup>3</sup>/hr. of water at 100 kPa pressure drop.  
\*\* K = The resistance coefficient of the valve. The constant (K) can be used to determine the equivalent length of pipe.

L =  $\frac{K \times D}{f}$  Where  
L = Equivalent length of pipe in feet  
K = Resistance coefficient  
D = Pipe diameter in feet  
f = Friction factor, related to type of pipe

# Valve Selection

## Valve & Actuator Weights

### Class 150

Valve Size	Basic Valve	With Bevel Gear Handwheel
3" 80mm	108 49	203 93
4" 100mm	138 63	235 107
6" 150mm	121 55	220 100
8" 200mm	177 81	296 135
10" 250mm	244 111	381 173
12" 300mm	368 167	526 239
14" 350mm	500 227	697 317
16" 400mm	600 273	874 397
18" 450mm	763 347	1052 478
20" 500mm	883 401	1179 535
22" 550mm	Contact DeZURIK	
24" 600mm	1365 620	1745 792
26" 650mm	1814 823	2326 1056
28" 700mm	2236 1015	2777 1260
30" 750mm	2584 1173	3113 1413
32" 800mm	3082 1398	3612 1639
36" 900mm	3831 1738	4412 2002
42" 1100mm	6504 2951	8100 3675
48" 1200mm	8415 3817	10042 4555
54" 1400mm	Contact DeZURIK	
60" 1500mm	Contact DeZURIK	

Pounds  
Kilograms

### Class 300

Valve Size	Basic Valve	With Bevel Gear Handwheel
3" 80mm	108 49	206 94
4" 100mm	139 64	239 109
6" 150mm	190 87	292 133
8" 200mm	293 133	446 203
10" 250mm	424 193	613 279
12" 300mm	659 299	920 418
14" 350mm	856 389	1236 561
16" 400mm	1054 479	1441 654
18" 450mm	1389 631	1813 823
20" 500mm	1688 766	2117 961
22" 550mm	Contact DeZURIK	
24" 600mm	2446 1110	2890 1311
26" 650mm	3006 1364	3637 1650
28" 700mm	3547 1609	4184 1898
30" 750mm	4361 1979	5023 2279
32" 800mm	Contact DeZURIK	
36" 900mm	6829 3098	7681 3485
42" 1100mm	Contact DeZURIK	
48" 1200mm	Contact DeZURIK	
54" 1400mm	Contact DeZURIK	
60" 1500mm	Contact DeZURIK	

Pounds  
Kilograms

### Class 300 Bonneted

Valve Size	Basic Valve	With Bevel Gear Handwheel
3" 80mm	269 123	367 167
4" 100mm	334 152	434 197
6" 150mm	414 188	516 235
8" 200mm	646 294	799 363
10" 250mm	1050 477	1239 563
12" 300mm	1438 653	1699 771
14" 350mm	1779 807	2159 980
16" 400mm	2137 970	2524 1145
18" 450mm	2571 1167	2995 1359
20" 500mm	3396 1541	3825 1735
22" 550mm	Contact DeZURIK	
24" 600mm	4440 2014	4884 2216
26" 650mm	5448 2472	6079 2758
28" 700mm	6138 2785	6775 3074
30" 750mm	8473 3844	9135 4144
32" 800mm	Contact DeZURIK	
36" 900mm	12829 5820	13681 6206
42" 1100mm	Contact DeZURIK	
48" 1200mm	Contact DeZURIK	
54" 1400mm	Contact DeZURIK	
60" 1500mm	Contact DeZURIK	

Pounds  
Kilograms

# Ordering

To order, simply complete the valve order code from information shown. An ordering example is shown for your reference.

## Valve Style

Give valve style code as follows:

KSV = Severe Service Knife Gate Valve

## Valve Size

Give valve size code as follows:

3 = 3" (80mm)	24 = 24" (600mm)
4 = 4" (100mm)	26 = 26" (650mm)
6 = 6" (150mm)	28 = 28" (700mm)
8 = 8" (200mm)	30 = 30" (750mm)
10 = 10" (250mm)	32 = 32" (800mm)
12 = 12" (300mm)	36 = 36" (900mm)
14 = 14" (350mm)	42 = 42" (1100mm)
16 = 16" (400mm)	48 = 48" (1200mm)
18 = 18" (450mm)	54 = 54" (1400mm)
20 = 20" (500mm)	60 = 60" (1500mm)
22 = 22" (550mm)	

2" (50mm) and 5" (125mm) on application

## End Connection

Give end connection code as follows:

F1 = Flanged, ASME 150  
 F110 = ISO 7005/PN10 Drilling  
 F116 = ISO 7005/PN16 Drilling  
 F1DA = AS2129 Table D Drilling  
 F1EA = AS2129 Table E Drilling  
 F1S10 = SANS 1123-1000  
 F1S16 = SANS 1123-1600  
 F2 = Flanged, ASME 300  
 F225 = ISO 7005/PN25 Drilling  
 F240 = ISO 7005/PN40 Drilling  
 F2FA = AS2129 Table F Drilling  
 F2S25 = SANS 1123-2500  
 F2S40 = SANS 1123-4000

Other end connections available on application.

## Body Material

Give body material code as follows:

CS = Carbon Steel  
 S2 = 316 Stainless Steel  
 S10 = 2205 Duplex Stainless Steel  
 LCC = Low Temperature Carbon Steel

## Packing Material

Give packing material code as follows:

GLCW = Expanded PTFE Fiber with Graphite live loading with copper wiper, 450°F (232°C)  
 TLCW = PTFE live loading with copper wiper, 450°F (232°C)  
 GLIW = Expanded PTFE Fiber with Graphite live loading with a Nickel-Chromium alloy wiper, 450°F (232°C)  
 TLIW = PTFE live loading with Nickel-Chromium alloy wipers, 450°F (232°C)

## On Application

RSCW = Rod Seal with copper wiper, bonneted valves only, 180°F (82°C)  
 RSIW = Rod Seal with a Nickel-Chromium wiper, bonneted valves only, 180°F (82°C)

**Note:** The limiting factor in valve selection is the lowest temperature of the packing or seat.

## Gate Material

Give gate material code as follows:

S10 = 2205 Duplex Stainless Steel  
 S8 = Hardened 400 Series Stainless Steel RC43  
 S5 = Hardened 17-4 PH Stainless Steel H900  
 S5C = Hardened 17-4 PH Stainless Steel H900 with a hardened nickel-based, non-stick coating  
 S5T = Hardened 17-4 PH Stainless Steel H900 with Tungsten Bevel  
 S5TC = Hardened 17-4 PH Stainless Steel H900 with Tungsten Bevel, with a hardened nickel-based, non-stick coating  
 CSHC = Carbon Steel Hardened RC43 with a hardened nickel-based, non-stick coating  
 ARC = Abrasion Resistant with a hardened nickel-based, non-stick coating

## Seat Material

Give seat material code as follows:

CS = Carbon Steel  
 S2 = 316 Stainless Steel  
 S5 = Hardened 17-4 PH Stainless Steel RC43 (NR seat facing only)  
 WIS = White Iron Solid (NR seat facing only)  
 NHS = Abrasion Resistant Cast Iron, per ASTM A532 (NR seat facing only)

## Seat Facing Overlay

Give seat facing code as follows:

NR = No coating  
 ST = Cobalt Chromium Alloy  
 TW13 = Tungsten Carbide (Welded) (13mm coating thickness)  
 TW6 = Tungsten Carbide (Welded) (6mm coating thickness)  
 CC13 = Chrome Carbide, (13mm coating thickness)  
 CC6 = Chrome Carbide, (6mm coating thickness)

## Seat Seals

Give option code as follows:

M = Metal  
 NBR = Acrylonitrile-Butadiene to 180°F (82°C)  
 CR = Chloroprene to 180°F (82°C)  
 HNBR = Hydrogenated Nitrile to 302°F (150°C)  
 FKM = Fluoro Rubber to 400°F (204°C)  
 EPDM = Terpolymer of Ethylene, Propylene and a Diene to 250°F (122°C)  
 VGF = Fluorinated Hydro Carbon Fluoro Rubber to 400°F (204°C)

**Note:** The limiting factor in valve selection is the lowest temperature of the packing or seat.

## Options

Give options code as follows:

CRT = Certified Physical and Chemical Test Report  
 CMC = Certificate of Material Conformance  
 SL37 = Custom Specification  
 SNCR = Custom Specification  
 DTR = DeZURIK Standard Certified Hydrostatic and Seat Test Report  
 CRN = Canadian Registration Number Certification

## On Application

B = Bonnet  
 DBB = Double Block and Bleed Design

## Ordering Example

KSV,6,F1,CS,GLCW,CSHC-CS-TW13,CR\*MNB-HD12-CS

# Bevel Gear Actuators

Bevel gear actuators provide vertical mounting of the handwheel. A mechanical advantage makes large valve operation easier and faster. Handwheels are sized for 80lb.(36Kg) rim pull maximum. All actuators are sized to the full pressure rating of the valve. See Pressure Ratings on Valve Selection page.

## Bevel Gear Handwheel Actuators

### Class 150

Valve Size	Order Code	Order Code	Number of Turns	Handwheel Diameter
	Carbon Steel (CS) Yoke	304 SST (S1) Yoke		
3" 80mm	MNB-HD12-CS	MNB-HD12-S1	60	12
4" 100mm	MNB-HD12-CS	MNB-HD12-S1	75	12
6" 150mm	MNB-HD12-CS	MNB-HD12-S1	106	12
8" 200mm	MNB-HD12-CS	MNB-HD12-S1	139	12
10" 250mm	MNB-HD12-CS	MNB-HD12-S1	173	12
12" 300mm	MNB-HD12-CS	MNB-HD12-S1	162	12
14" 350mm	MNB-HD16-CS	MNB-HD16-S1	177	16
16" 400mm	MNB-HD16-CS	MNB-HD16-S1	201	16
18" 450mm	MNB-HD24-CS	MNB-HD24-S1	225	24
20" 500mm	MNB-HD24-CS	MNB-HD24-S1	249	24
22" 550mm	MNB-HD24-CS	MNB-HD24-S1	*	24
24" 600mm	MNB-HD24-CS	MNB-HD24-S1	198	24
26" 650mm	MNB-HD24-CS	MNB-HD24-S1	430	24
28" 700mm	MNB-HD24-CS	MNB-HD24-S1	462	24
30" 750mm	MNB-HD24-CS	MNB-HD24-S1	494	24
32" 800mm	MNB-HD24-CS	MNB-HD24-S1	524	24
36" 900mm	MNB-HD24-CS	MNB-HD24-S1	443	24
42" 1100mm	MNB-HD24-CS	MNB-HD24-S1	3078	24
48" 1200mm	MNB-HD24-CS	MNB-HD24-S1	3510	24

### Class 300

Valve Size	Order Code	Order Code	Number of Turns	Handwheel Diameter
	Carbon Steel (CS) Yoke	304 SST (S1) Yoke		
3" 80mm	MNB-HD12-CS	MNB-HD12-S1	48	12
4" 100mm	MNB-HD12-CS	MNB-HD12-S1	59	12
6" 150mm	MNB-HD12-CS	MNB-HD12-S1	82	12
8" 200mm	MNB-HD12-CS	MNB-HD12-S1	110	12
10" 250mm	MNB-HD24-CS	MNB-HD24-S1	134	24
12" 300mm	MNB-HD24-CS	MNB-HD24-S1	159	24
14" 350mm	MNB-HD24-CS	MNB-HD24-S1	232	24
16" 400mm	MNB-HD24-CS	MNB-HD24-S1	265	24
18" 450mm	MNB-HD24-CS	MNB-HD24-S1	296	24
20" 500mm	MNB-HD24-CS	MNB-HD24-S1	328	24
22" 550mm	MNB-HD24-CS	MNB-HD24-S1	*	24
24" 600mm	MNB-HD24-CS	MNB-HD24-S1	392	24
26" 650mm	MNB-HD24-CS	MNB-HD24-S1	848	24
28" 700mm	MNB-HD24-CS	MNB-HD24-S1	912	24
30" 750mm	MNB-HD24-CS	MNB-HD24-S1	732	24
32" 800mm	MNB-HD24-CS	MNB-HD24-S1	792	24
36" 900mm	MNB-HD24-CS	MNB-HD24-S1	888	24
42" 1100mm	MNB-HD24-CS	MNB-HD24-S1	O/A	O/A
48" 1200mm	MNB-HD24-CS	MNB-HD24-S1	O/A	O/A

Note:  
For alternate mounting of bevel gear actuators, add -90, -180 or -270 after the actuator code and as 2nd line information on the order.

\* = Contact DeZURIK

# Cylinder Actuators

Double-acting hydraulic cylinders for on/off services are sized for 1500 psig (10350 kPa) with a 2:1 safety factor capable of maximum non-shock pressure. All actuators are sized to the full pressure rating of the valve. See Pressure Ratings on Valve Selection page.

## Class 150

Valve Size	Order Code		Hydraulic Cylinder Diameter	Area		Swept Volume	
	Carbon Steel (CS) Yoke	304 SST (S1) Yoke		ln <sup>2</sup> cm <sup>2</sup>	ln <sup>3</sup> cm <sup>3</sup>	Open	Closed
				Open	Closed	Open	Closed
3" 80mm	CY-HC2-CS	CY-HC2-S1	2" 50mm	2.36 15.23	3.14 20.26	9 147	13 213
4" 100mm	CY-HC2-CS	CY-HC2-S1	2" 50mm	2.36 15.23	3.14 20.26	12 197	16 262
6" 150mm	CY-HC2-CS	CY-HC2-S1	2" 50mm	2.36 15.23	3.14 20.26	16 262	22 361
8" 200mm	CY-HC2.5-CS	CY-HC2.5-S1	2.5" 65mm	4.12 26.58	4.91 31.68	37 606	44 721
10" 250mm	CY-HC2.5-CS	CY-HC2.5-S1	2.5" 65mm	4.12 26.58	4.91 31.68	45 737	54 885
12" 300mm	CY-HC3.25-CS	CY-HC3.25-S1	3.25" 80mm	6.81 43.94	8.30 53.55	89 1458	108 1770
14" 350mm	CY-HC3.25-CS	CY-HC3.25-S1	3.25" 80mm	6.81 43.94	8.30 53.55	102 1671	124 2032
16" 400mm	CY-HC4-CS	CY-HC4-S1	4" 100mm	10.16 65.55	12.57 81.10	173 2835	214 3507
18" 450mm	CY-HC4-CS	CY-HC4-S1	4" 100mm	10.16 65.55	12.57 81.10	193 3163	239 3916
20" 500mm	CY-HC4-CS	CY-HC4-S1	4" 100mm	10.16 65.55	12.57 81.10	213 3490	264 4326
22" 550mm	CY-HC4-CS	CY-HC4-S1	4" 100mm	10.16 65.55	12.57 81.10	233 3818	289 4736
24" 600mm	CY-HC4-CS	CY-HC4-S1	4" 100mm	10.16 65.55	12.57 81.10	254 4162	314 5146
26" 650mm	CY-HC5-CS	CY-HC5-S1	5" 125mm	16.49 106.39	19.63 126.64	445 7292	530 8685
28" 700mm	CY-HC5-CS	CY-HC5-S1	5" 125mm	16.49 106.39	19.63 126.64	478 7833	569 9324
30" 750mm	CY-HC5-CS	CY-HC5-S1	5" 125mm	16.49 106.39	19.63 126.64	511 8374	609 9980
32" 800mm	CY-HC5-CS	CY-HC5-S1	5" 125mm	16.49 106.39	19.63 126.64	544 8915	648 10619
36" 900mm	CY-HC6-CS	CY-HC6-S1	6" 150mm	23.37 150.77	28.27 182.39	865 14175	1046 17141
42" 1100mm	CY-HC10-CS	CY-HC10-S1	10" 250mm	62.64 404.13	78.54 506.71	2694 44147	3377 55339
48" 1200mm	CY-HC10-CS	CY-HC10-S1	10" 250mm	62.64 404.13	78.65 507.42	3069 50292	3848 63057
54" 1400mm	Contact DeZURIK						
60"							
1500mm							

# Cylinder Actuators

## Class 300

Valve Size	Order Code		Hydraulic Cylinder Diameter	Area		Swept Volume		In <sup>3</sup> cm <sup>3</sup>	
	Carbon Steel (CS) Yoke	304 SST (S1) Yoke		Open	Closed	Open	Closed		
3" 80mm	CY-HC2-CS	CY-HC2-S1	2" 50mm	2.36 15.23	3.14 20.26	9 147	13 213		
4" 100mm	CY-HC2.5-CS	CY-HC2.5-S1	2.5" 65mm	4.12 26.58	4.91 31.68	21 344	25 410		
6" 150mm	CY-HC2.5-CS	CY-HC2.5-S1	2.5" 65mm	4.12 26.58	4.91 31.68	29 475	34 557		
8" 200mm	CY-HC3.25-CS	CY-HC3.25-S1	3.25" 80mm	6.81 43.94	8.30 53.55	48 787	58 950		
10" 250mm	CY-HC4-CS	CY-HC4-S1	4" 100mm	10.16 65.55	12.57 81.10	112 1835	138 2261		
12" 300mm	CY-HC4-CS	CY-HC4-S1	4" 100mm	10.16 65.55	12.57 81.10	132 2163	163 2671		
14" 350mm	CY-HC5-CS	CY-HC5-S1	5" 125mm	16.49 106.39	19.63 126.64	247 4048	295 4834		
16" 400mm	CY-HC5-CS	CY-HC5-S1	5" 125mm	16.49 106.39	19.63 126.64	280 4588	334 5473		
18" 450mm	CY-HC6-CS	CY-HC6-S1	6" 150mm	23.37 150.77	28.27 182.39	444 7276	537 8800		
20" 500mm	CY-HC6-CS	CY-HC6-S1	6" 150mm	23.37 150.77	28.27 182.39	491 8046	594 9734		
22" 550mm	CY-HC6-CS	CY-HC6-S1	6" 150mm	23.37 150.77	28.27 182.39	538 8816	651 10668		
24" 600mm	CY-HC6-CS	CY-HC6-S1	6" 150mm	23.37 150.77	28.27 182.39	584 9586	707 11602		
26" 650mm	CY-HC7-CS	CY-HC7-S1	7" 180mm	31.42 202.71	38.48 248.26	848 13896	1039 17026		
28" 700mm	CY-HC7-CS	CY-HC7-S1	7" 180mm	31.42 202.71	38.48 248.26	911 14929	1116 18288		
30" 750mm	CY-HC7-CS	CY-HC7-S1	7" 180mm	31.42 202.71	38.48 248.26	974 15961	1193 19550		
32" 800mm	CY-HC8-CS	CY-HC8-S1	8" 200mm	40.64 262.19	50.27 324.32	1425 23351	1659 27186		
36" 900mm	CY-HC8-CS	CY-HC8-S1	8" 200mm	40.64 262.19	50.27 324.32	1504 24646	1860 30480		
42" 1100mm	CY-HC10-CS	CY-HC10-S1	10" 250mm	62.64 404.13	78.54 506.71	2694 44147	3377 55339		
48" 1200mm	CY-HC10-CS	CY-HC10-S1	10" 250mm	62.64 404.13	78.65 507.42	3069 50292	3848 63057		
54" 1400mm	Contact DeZURIK								
60" 1500mm									

## Lockout Device

The KSV Lockout Device is designed to hold the full actuator force plus a safety factor. Available on bevel gear handwheel and cylinder actuated valves. To order, add a comma and the order code "LK" after the actuator code.

### Ordering Example:

KSV,6,F1,CS,GLCW,CSHC-CS-TW13,CR\*MNB-HD12-CS,LK

# Dimensions

## Bevel Gear Actuators

### Class 150, 3-10" (80-250mm) Valves

Valve Size	A	B	C	D	E	F	G	H	I	J
3" 80mm	32.26 819	25.32 643	5.00 127	4.13 105	13.00 330	6.00 152	10.03 255	12.00 305	10.25 260	4.00 102
4" 100mm	33.49 851	26.80 681	5.50 140	5.00 127	13.00 330	6.00 152	10.03 255	12.00 305	10.25 260	4.13 105
6" 150mm	38.31 973	29.49 749	5.94 151	5.50 140	13.00 330	6.00 152	10.03 255	12.00 305	10.25 260	2.50 64
8" 200mm	45.18 1148	32.74 832	7.00 178	6.75 171	13.00 330	6.00 152	10.03 255	12.00 305	10.25 260	2.88 73
10" 250mm	52.40 1331	37.96 964	8.31 211	8.00 203	13.00 330	6.50 165	10.03 255	12.00 305	10.25 260	3.13 80

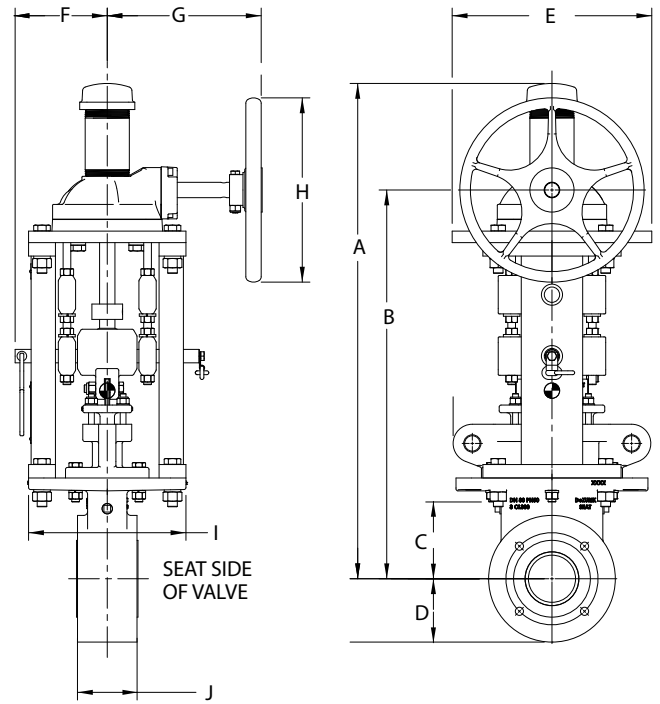

### Class 150, 12" & Larger (300mm & Larger) Valves

Valve Size	A	B	C	D	E	F	G	H	I	J
12" 300mm	60.43 1535	44.99 1143	10.00 254	9.50 241	29.00 737	6.50 165	10.09 256	12.00 305	10.25 260	3.25 83
14" 350mm	64.33 1634	48.30 1227	11.13 283	10.50 267	31.00 787	8.92 227	10.34 263	16.00 406	12.25 311	3.63 92
16" 400mm	73.49 1867	53.05 1347	12.88 327	11.75 298	33.50 851	8.97 228	10.34 263	16.00 406	13.75 349	3.75 95
18" 450mm	78.49 1994	58.05 1474	14.28 363	12.50 318	35.00 889	8.25 210	18.34 466	24.00 610	14.25 362	4.13 105
20" 500mm	84.12 2137	61.68 1567	16.50 419	13.75 349	37.50 953	8.00 203	18.34 466	24.00 610	14.25 362	4.50 114
22" 550mm	Contact DeZURIK									
24" 600mm	96.82 2459	71.60 1819	19.00 483	16.00 406	42.00 1067	8.86 225	20.98 533	24.00 610	14.63 372	5.00 127
26" 650mm	104.90 2664	77.18 1960	20.88 530	17.13 435	44.25 1124	9.38 238	21.16 537	24.00 610	16.50 419	6.75 171
28" 700mm	118.81 3018	81.87 2079	23.75 603	18.25 464	46.50 1181	10.55 268	21.16 537	24.00 610	17.00 432	7.13 181
30" 750mm	120.88 3070	83.93 2132	23.13 588	19.38 492	48.75 1238	9.94 252	21.16 537	24.00 610	19.00 483	7.38 187
32" 800mm	124.45 3161	87.49 2222	22.86 581	20.88 530	51.75 1314	10.00 254	21.16 537	24.00 610	18.00 457	8.13 207
36" 900mm	136.20 3459	98.18 2494	24.52 623	23.00 584	61.00 1549	10.00 254	21.16 537	24.00 610	18.00 457	8.88 226
42" 1100mm	160.74 4083	118.79 3017	34.25 870	26.75 679	68.50 1740	14.00 356	27.66 703	24.00 610	28.00 711	9.75 248
48" 1200mm	177.99 4521	130.04 3303	40.00 1016	30.00 762	75.00 1905	14.00 356	27.66 703	24.00 610	28.00 711	11.50 292

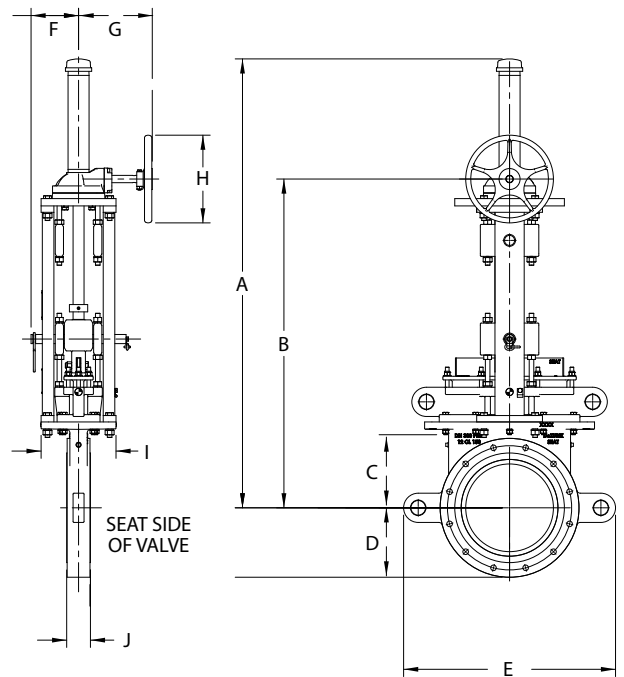

# Dimensions

## Bevel Gear Actuators

### Class 300, 3-6" (80-150mm) Valves

Valve Size	A	B	C	D	E	F	G	H	I	J
3" 80mm	32.26 819	25.32 643	4.69 119	4.13 105	13.00 330	6.00 152	10.03 255	12.00 305	10.25 260	4.00 102
4" 100mm	33.49 851	26.80 681	5.50 140	5.00 127	13.00 330	6.00 152	10.03 255	12.00 305	10.25 260	4.13 105
6" 150mm	39.09 993	30.28 769	7.00 178	6.25 159	13.00 330	6.00 152	10.03 255	12.00 305	10.25 260	4.13 105

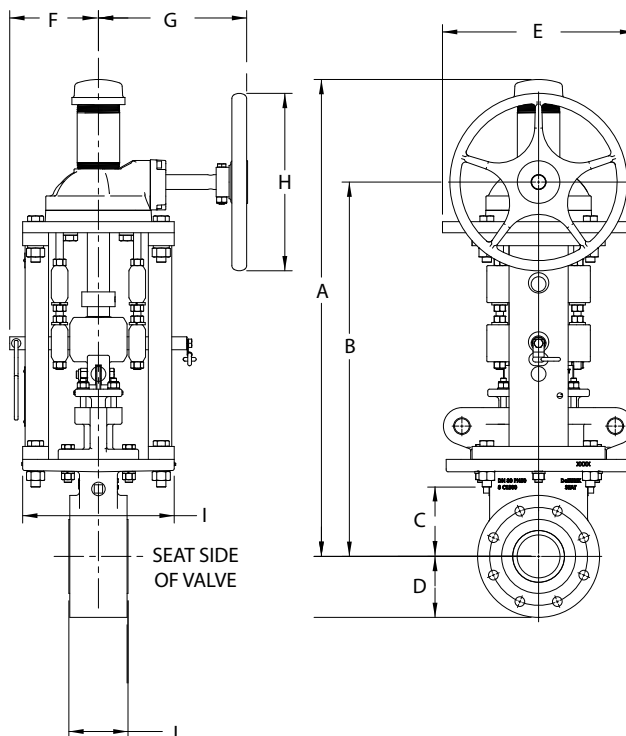

### Class 300, 8" & Larger (200mm & Larger) Valves

Valve Size	A	B	C	D	E	F	G	H	I	J
8" 200mm	51.70 1313	37.30 947	8.25 210	7.50 191	24.00 610	6.50 165	10.03 255	12.00 305	10.50 267	4.63 118
10" 250mm	54.49 1384	41.43 1052	9.25 235	8.75 222	27.50 699	6.50 165	18.34 466	24.00 610	11.75 298	5.38 137
12" 300mm	62.22 1580	47.08 1196	10.40 264	10.19 259	30.50 775	8.25 210	18.34 466	24.00 610	14.50 368	5.63 143
14" 350mm	66.51 1689	51.30 1303	11.81 300	11.50 292	33.00 838	9.00 229	21.16 537	24.00 610	16.38 416	6.25 159
16" 400mm	74.01 1880	54.56 1386	13.75 349	12.75 324	35.50 902	9.57 243	21.16 537	24.00 610	16.38 416	6.63 168
18" 450mm	80.95 2056	59.99 1524	14.63 372	14.00 356	38.00 965	9.00 229	21.16 537	24.00 610	16.13 410	7.00 178
20" 500mm	84.95 2158	63.99 1625	16.63 422	15.25 387	40.50 1029	9.00 229	21.16 537	24.00 610	16.13 410	7.44 189
22" 550mm	Contact DeZURIK									
24" 600mm	97.13 2467	72.18 1833	17.66 449	18.00 457	46.00 1168	9.00 229	21.16 537	24.00 610	16.13 410	8.50 216
26" 650mm	107.26 2724	82.41 2093	20.13 511	19.13 486	48.25 1226	10.50 267	25.55 649	24.00 610	19.00 483	8.50 216
28" 700mm	112.38 2854	85.53 2172	21.25 540	20.38 518	48.88 1242	10.50 267	25.55 649	24.00 610	19.00 483	10.00 254
30" 750mm	124.01 3150	89.66 2277	22.88 581	21.50 546	53.00 1346	10.50 267	25.55 649	24.00 610	19.00 483	10.50 267
32" 800mm	129.13 3280	94.78 2407	24.50 622	22.63 575	60.25 1530	12.61 320	25.55 649	24.00 610	22.50 572	11.50 292
36" 900mm	138.07 3507	102.66 2608	27.13 689	25.00 635	65.50 1664	12.61 320	25.55 649	24.00 610	22.50 572	12.00 305
42-48" 1100-1200mm	Contact DeZURIK									

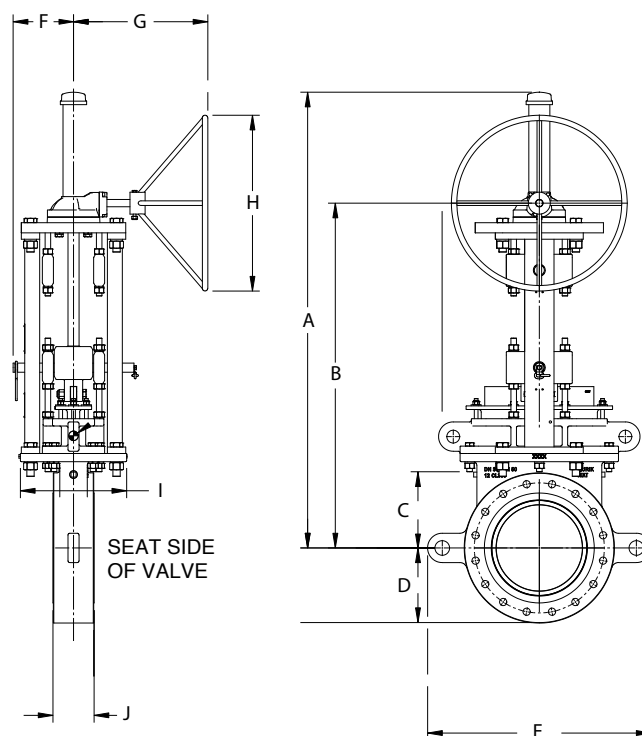



# Dimensions

## Hydraulic Cylinder Actuators

### Class 150, 3-10" (80-250mm) Valves

Valve Size	A	B	C	D	E	F	G	I	J
3" 80mm	33.52 851	22.64 575	5.00 127	4.13 105	13.00 330	6.00 152	6.61 168	10.25 260	4.00 102
4" 100mm	36.00 914	24.13 613	5.50 140	5.00 127	13.00 330	6.00 152	6.57 167	10.25 260	4.13 105
6" 150mm	41.07 1043	26.81 681	5.94 151	5.50 140	13.00 330	6.00 152	6.57 167	10.25 260	2.50 64
8" 200mm	46.06 1170	30.06 764	7.00 178	6.75 171	13.00 330	6.00 152	6.57 167	10.25 260	2.88 73
10" 250mm	53.53 1360	35.28 896	8.31 211	8.00 203	13.00 330	6.50 165	7.07 180	10.25 260	3.13 80

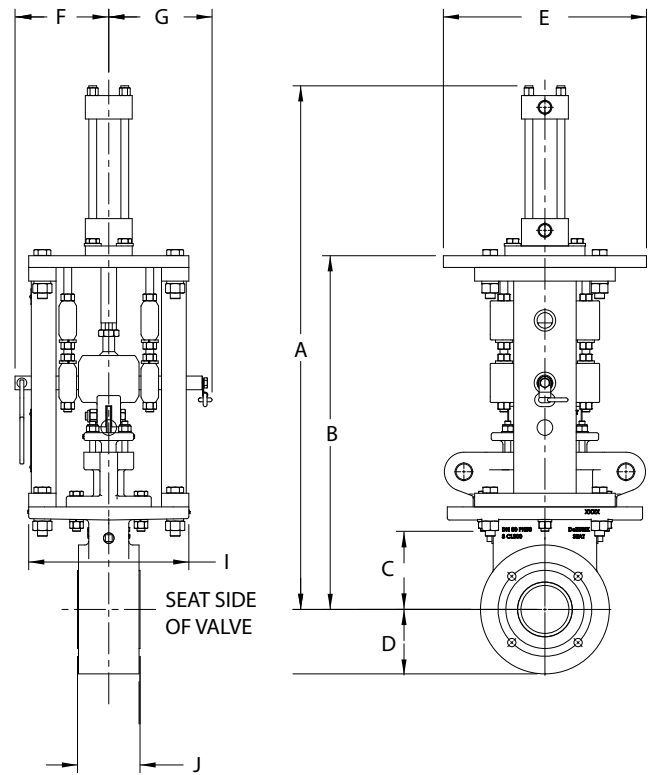

### Class 150, 12" & Larger (300mm & Larger) Valves

Valve Size	A	B	C	D	E	F	G	I	J
12" 300mm	63.56 1614	42.31 1075	10.00 254	9.50 241	29.00 737	7.07 180	6.50 165	10.25 260	3.25 83
14" 350mm	68.13 1731	45.63 1159	11.50 292	10.50 267	31.00 787	7.97 202	8.25 210	12.25 311	3.63 92
16" 400mm	75.37 1914	50.38 1280	13.50 343	11.75 298	33.50 851	8.82 224	8.25 210	13.75 349	3.75 95
18" 450mm	82.25 2089	55.38 1407	14.88 378	12.50 318	35.00 889	8.01 203	8.56 217	14.25 362	4.13 105
20" 500mm	87.88 2232	59.00 1499	16.50 419	13.75 349	37.50 953	8.00 203	8.57 218	14.25 362	4.50 114
22" 550mm	Contact DeZURIK								
24" 600mm	100.88 2562	68.00 1727	19.38 492	16.00 406	42.00 1067	8.25 210	8.86 225	14.63 372	5.00 127
26" 650mm	109.19 2773	73.31 1862	20.88 530	17.13 435	44.25 1124	9.38 238	9.67 246	16.50 419	6.75 171
28" 700mm	115.75 2940	78.00 1981	23.50 597	18.25 464	46.50 1181	10.55 268	9.94 252	17.00 432	7.13 181
30" 750mm	119.82 3043	80.06 2034	23.13 588	19.38 492	48.75 1238	9.94 252	10.55 268	19.00 483	7.38 187
32" 800mm	125.25 3181	83.63 2124	24.65 626	20.88 530	51.75 1314	10.00 254	10.61 269	18.00 457	8.13 207
36" 900mm	141.56 3596	94.31 2395	28.63 727	23.00 584	61.00 1549	10.00 254	10.61 269	18.00 457	8.88 226
42" 1100mm	170.19 4323	111.38 2829	34.25 870	26.75 679	68.50 1740	14.00 356	14.00 356	28.00 711	9.75 248
48" 1200mm	187.44 4761	122.63 3115	40.00 1016	30.00 762	75.00 1905	14.00 356	14.00 356	28.00 711	11.50 292

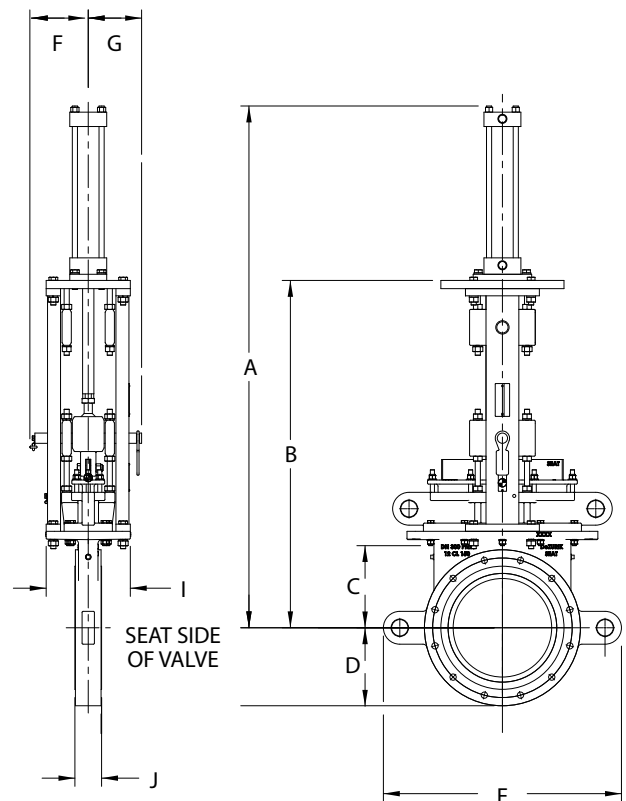

# Dimensions

## Hydraulic Cylinder Actuators

### Class 300, 3-6" (80-150mm) Valves

Valve Size	A	B	C	D	E	F	G	I	J
3" 80mm	33.64 854	22.64 575	4.69 119	4.13 105	13.00 330	6.00 152	6.61 168	10.25 260	4.00 102
4" 100mm	35.88 911	24.13 613	5.50 140	5.00 127	13.00 330	6.00 152	6.57 167	10.25 260	4.13 105
6" 150mm	41.35 1050	27.60 701	7.00 178	6.25 159	13.00 330	6.00 152	6.61 168	10.25 260	4.13 105

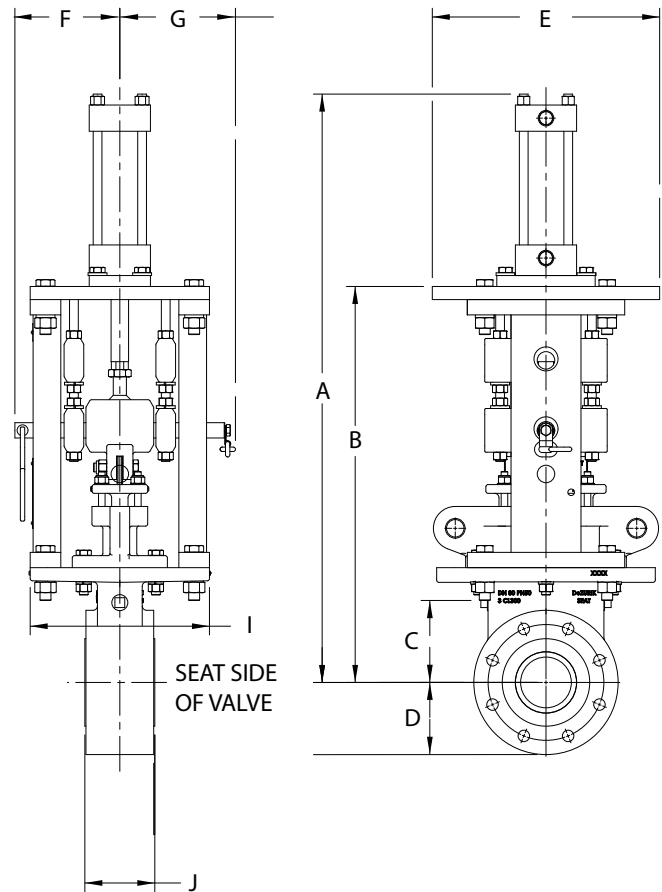

### Class 300, 8" & Larger (200mm & Larger) Valves

Valve Size	A	B	C	D	E	F	G	I	J
8" 200mm	51.63 1311	34.63 880	8.25 210	7.50 191	24.00 610	7.11 181	6.50 165	10.50 267	4.63 118
10" 250mm	58.13 1477	38.75 984	9.25 235	8.75 222	26.50 673	6.50 165	7.07 180	11.75 298	5.38 137
12" 300mm	65.78 1671	44.40 1128	10.40 264	10.25 260	30.50 775	8.72 221	8.38 213	14.50 368	5.63 143
14" 350mm	70.94 1802	47.44 1205	12.25 311	11.50 292	33.00 838	9.00 229	9.59 244	16.38 416	6.25 159
16" 400mm	76.20 1935	50.69 1288	13.75 349	12.75 324	35.50 902	9.00 229	9.57 243	16.38 416	6.63 168
18" 450mm	85.38 2169	56.13 1426	14.63 372	14.00 356	38.00 965	9.00 229	8.72 221	16.13 410	7.00 178
20" 500mm	90.88 2308	60.13 1527	16.63 422	15.25 387	40.50 1029	9.00 229	9.60 244	16.13 410	7.44 189
22" 550mm	Contact DeZURIK								
24" 600mm	103.06 2618	68.31 1735	19.00 483	18.00 457	46.00 1168	9.00 229	9.60 244	16.13 410	8.50 216
26" 650mm	113.94 2894	75.94 1929	20.13 511	19.13 486	48.25 1226	10.50 267	11.07 281	19.00 483	8.50 216
28" 700mm	119.06 3024	79.06 2008	21.25 540	20.38 518	50.75 1289	10.50 267	11.07 281	19.00 483	10.00 254
30" 750mm	125.19 3180	83.19 2113	22.58 574	21.50 546	53.00 1346	10.50 267	11.11 282	19.00 483	10.50 267
32" 800mm	134.06 3405	88.31 2243	24.50 622	22.63 575	60.25 1530	12.03 306	12.58 320	22.50 572	11.50 292
36" 900mm	145.94 3707	96.19 2443	27.13 689	25.00 635	65.50 1664	12.61 320	12.00 305	22.50 572	12.00 305
42-48" 1100-1200mm	Contact DeZURIK								

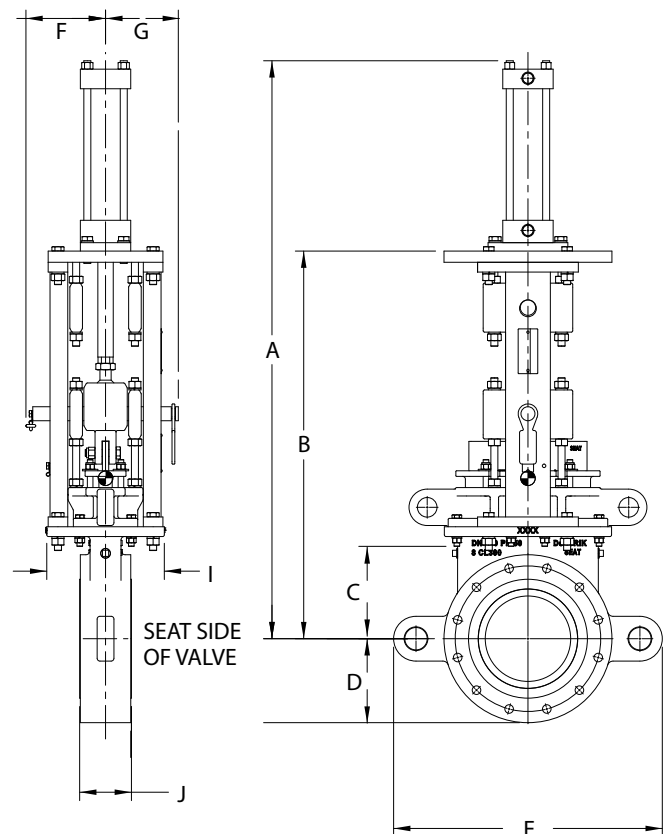



Need Knife Gate Valve pricing or support for your mining project? Contact us for more assistance.

**Perth Branch**

U2/41-45 Furnace Road  
Welshpool WA 6106  
Phone: +61 8 9353 2565  
[sales@thevalvecompany.com.au](mailto:sales@thevalvecompany.com.au)

**Kalgoorlie Branch**

2/69 Craig Road  
West Kalgoorlie WA 6430  
Phone: +61 8 9021 6668  
[sales@thevalvecompany.com.au](mailto:sales@thevalvecompany.com.au)

**Brisbane Branch**

U5/225 Queensport Road  
North Murrarie QLD 4172  
Phone: +61 7 3348 8636  
[sales@thevalvecompany.com.au](mailto:sales@thevalvecompany.com.au)

**Bunbury Branch**

Phone: +61 417 744 791  
[sales@thevalvecompany.com.au](mailto:sales@thevalvecompany.com.au)