

DeZURIK KUL URETHANE LINED KNIFE GATE VALVES



Design and Construction

DeZURIK's KUL Urethane Lined Knife Gate Valves are designed for on-off applications of abrasive slurry and dry abrasive materials. Urethane Lined Knife Gate Valves are ideally suited for applications in mining, chemical and food industries.

Standard Flanged Urethane Lined Knife Gate Valves are available in sizes 2-48" (50-1200mm). Grooved End Valves are available in sizes 2-12" (50-300mm).

Extended Flanged Valves are available in two face-to-face lengths: long pattern in sizes 2-48" (50-600mm) with dimensions that conform to typical long-pattern push-through style slurry valves with flange retainers; and short pattern in sizes 2-8" (50-200mm) with dimensions that conform to typical short pattern push-through style slurry valves without flange retainers.

Temperature ratings range from -20 to 265° F (-29 to 130° C) as standard. The cast ductile iron body is available with a variety of urethane liner compounds suitable for water, oil, food grade, phosphoric acid, petroleum and high temperature service to 265° F (130° C).

KUL valves feature a one-piece, cast-in-place bonded liner that provides bi-directional, leak tight/zero leakage shutoff to either 150 or 250 psi (1030 or 1720 kPa) CWP. Urethane Lined Knife Gate Valves can also provide bi-directional dead-end service to the full pressure rating of the valve. All wetted surfaces are lined with urethane.



Port Area

The round port design allows high flow capacity and minimum pressure drop. The inside port diameter of the flanged KUL conforms to ASME B36.10 for sizes 4 inch and larger. The inside diameter of the grooved end KUL conforms to valve standard MSS SP-81 for size 4" and larger.

One-Piece, Bonded Urethane Liner

The urethane liner is bonded in place to form a continuous liner throughout the entire body, chest, packing chamber and flange face area. The bonding process enhances the mechanical and abrasion resistance properties of the urethane, which creates a robust seat seal in harsh slurry services.

The seamless bonded urethane liner extends over the flange face to serve as the valve's flange gasket in the standard KUL flanged body style. No additional gaskets are required. The KUL extended flange urethane liner encompasses the entire flange face and can serve as the gasket when mounted to raised face flanges. Gaskets are recommended only when the KUL-EF is mounted to mating flat-faced flanges.



No Discharge to Atmosphere

The KUL Knife Gate Valve is an enclosed design which keeps all process media contained within the pipeline. When the KUL valve is actuated, it slices through the media or slurry and does not allow any discharge to atmosphere, unlike a push-through design which allows process media to discharge into the environment.

The KUL-EF Extended Flange is a direct dimensional replacement to the long-body style slurry push-through valves providing zero-leakage shut-off and no discharge to atmosphere.

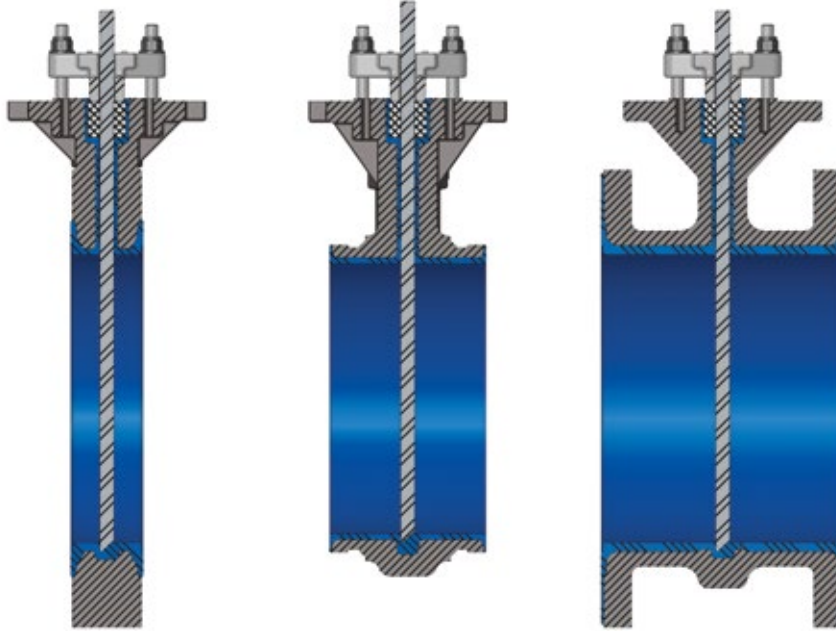

Standard Flanged Body

Grooved End Body

Extended Flanged Body

Connection and Body Configuration Options

Standard Flanged Body

ASME flange drilling conforms to ASME B16.1 Class 125, ASME B16.5 Class 150 and ASME B16.42 Class 150; large diameter flange drilling conforms to ASME B16.47 Series A.

MSS-SP81 Knife Gate Valve standard, valve sizes 2-24" (50-600mm) conform to valve face-to-face dimensions.

MSS-SP151 Pressure testing of valves.

Grooved End Body

ANSI/AWWA C606 Standard for Grooved and Shouldered Joints.

MSS-SP151 Pressure testing of valves.

Extended Flange Body

ASME flange drilling conforms to ASME B16.1 Class 125, ASME B16.5 Class 150 and ASME B16.42 Class 150; large diameter flange drilling conforms to ASME B16.47 Series A.

Face-to-Face dimensions conform to typical long-pattern push-through design slurry valves.

MSS-SP151 Pressure testing of valves.

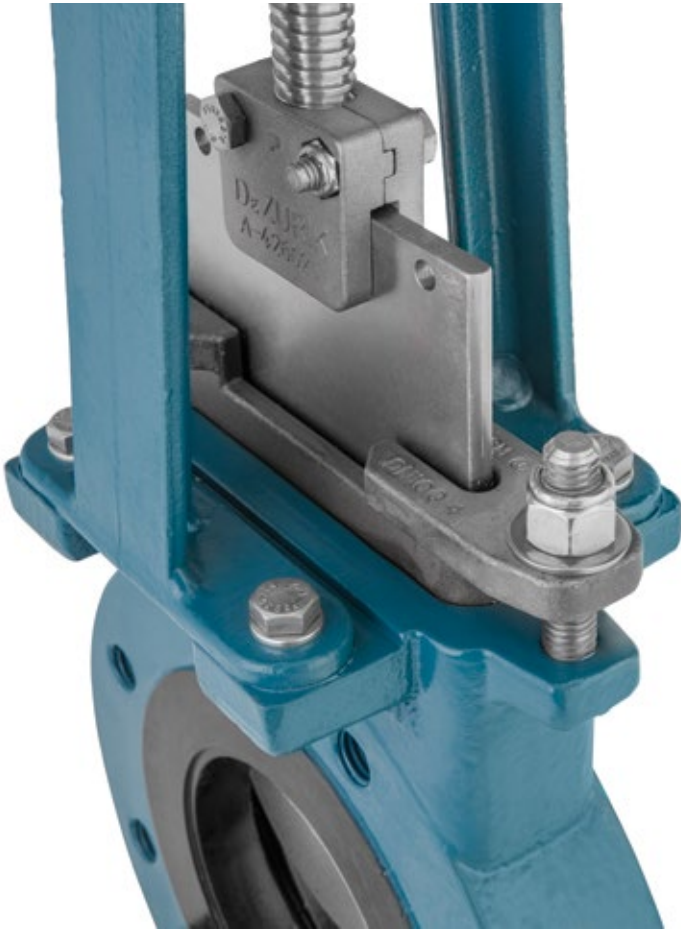

Exclusive Rounded Gate

A durable gate resists damage and allows higher pressure drops. Gate material options include stainless steels, including duplex and heat-treated stainless steel, and Hastelloy C. The gate is finish ground on all sides and edges to ensure long packing and seat life. To increase packing life and provide a superior seal, the gate edges are rounded. The gate includes a knife-like bevel that pushes aside or cuts through thick slurries or solids in the flow. A high strength investment cast gate clip complements KUL's robust construction.

Stainless Steel Stem

All valves are furnished with a stainless steel stem as standard for extra corrosion resistance, long life and easy operation. The stem has single-lead threads to minimize wear and reduce operating torque requirements of the valve.

Reliable Long-Life Packing

Multiple packing material options ensure a tight seal with a minimum of packing gland pressure. Three rings of packing and a smooth uniform urethane lined chamber assure a tight seal.

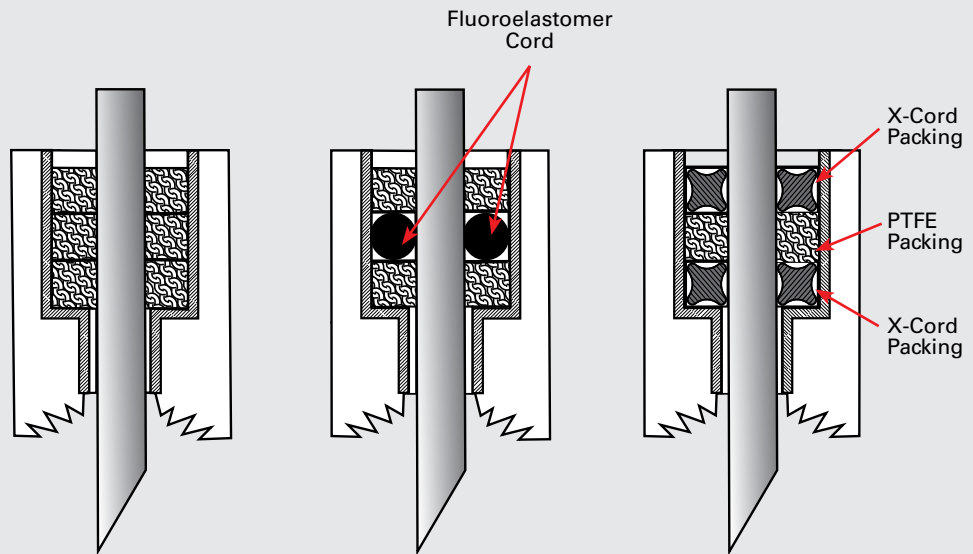

SMP
PTFE Square Braided Packing

FGP
Food Grade Service

TDP
Dry Service, Dry PTFE Braided Packing with Solid PTFE Cord

ASP
Self-adjusting PTFE Braided Packing with Fluoroelastomer Cord

NXS
NBR X-Cord with PTFE Square Braided Packing Cord

Choice of Actuators

The DeZURIK KUL Urethane Lined Knife Gate Valve is offered with a choice of handwheel, chainwheel, bevel gear, pneumatic or hydraulic cylinder, or electric motor actuators.

Corrosion Resistant Yoke Sleeve

A bronze yoke sleeve provides corrosion resistance and assures easy operation. An added grease fitting provides lubricant to the stem thread and yoke sleeve.

Heavy-Duty Superstructure

The standard actuator superstructure is available in carbon steel or stainless steel and is designed to stand up under the most difficult operating conditions. For valves mounted in horizontal installations, strengthened actuator legs are available.

Accessories

A wide variety of accessories are available including handwheel extensions, floorstands, lockouts and various cylinder actuator accessories for customizing the valve/actuator package to meet specific application requirements.



Ten 10" (250mm) DeZURIK KUL Urethane Lined Knife Gate Valves are installed in a hydrocyclone nest at a copper mine. These valves lasted two times longer than the competitor's valves in this service.

Materials of Construction

Item	Description	Material
A1	Body	Ductile Iron, ASTM A395, Grade 65-45-15 with Urethane Liner
A2	Packing	SMP - PTFE Square Braided Packing to 500°F (260°C) (pH Range 0-14)
		ASP - Self-Adjusting PTFE Braided Packing with Fluoroelastomer Cord to 400°F (204°C) (pH Range 0-14)
		TDP - Dry Service, Dry PTFE Braided Packing with Solid PTFE Cord to 500°F (260°C) (pH Range 0-14)
		FGP - Food Grade Service to 450°F (232°C) (pH Range 3-11)
A3	Gate	NXS - NBR X-Cord with PTFE Square Braided Packing Cord to 250°F (120°C). Check Chemical Compatibility.
		304 Stainless Steel, ASTM A240
		316 Stainless Steel, ASTM A240
		17-4 Stainless Steel H900 Heat Treated, ASTM A564, Type 630 Condition H900
		254-SMO Stainless Steel, ASTM A240 S31254
		410 Stainless Steel, ASTM A240
		2205 Duplex Stainless Steel, ASTM A240 S31803 or S32205
Hastelloy C, ASTM B575 C276		
A4	Gland	316 Stainless Steel, ASTM A351, Type CF-8M
A5	Stud	Stainless Steel 18-8 or 304
A6	Washer	Stainless Steel 18-8 or 304
A7	Nut	Stainless Steel 18-8 or 304 with nylon insert

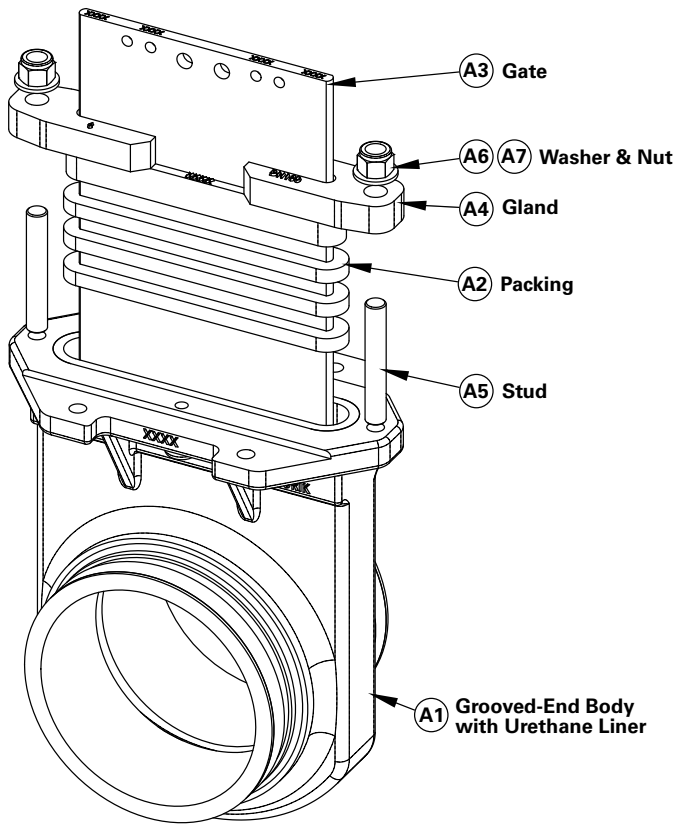
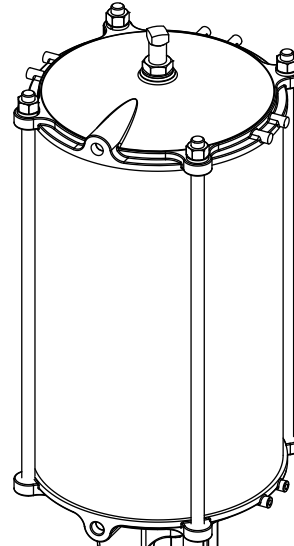

Grooved End Body

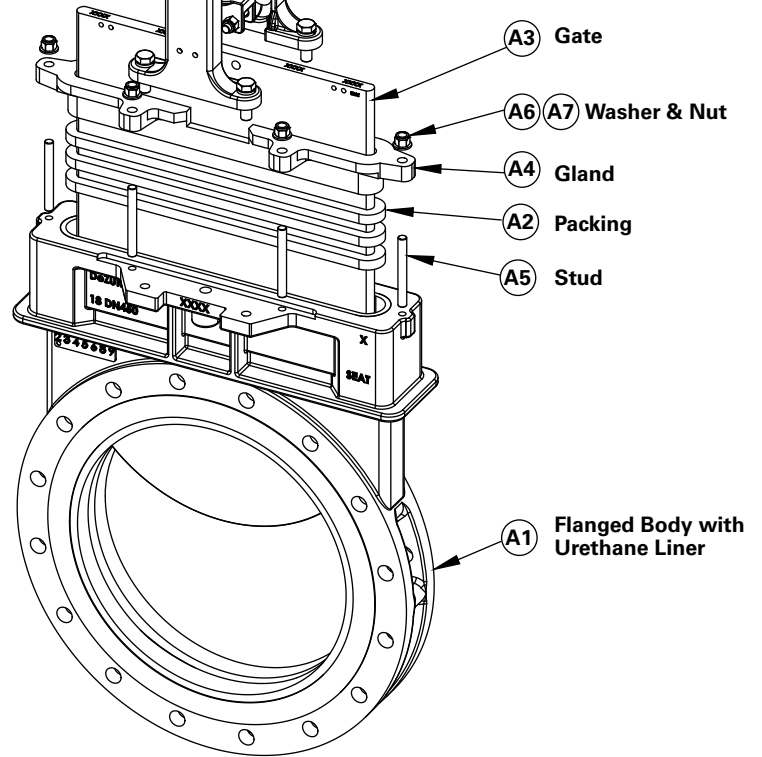

Standard Flanged Body

Materials of Construction

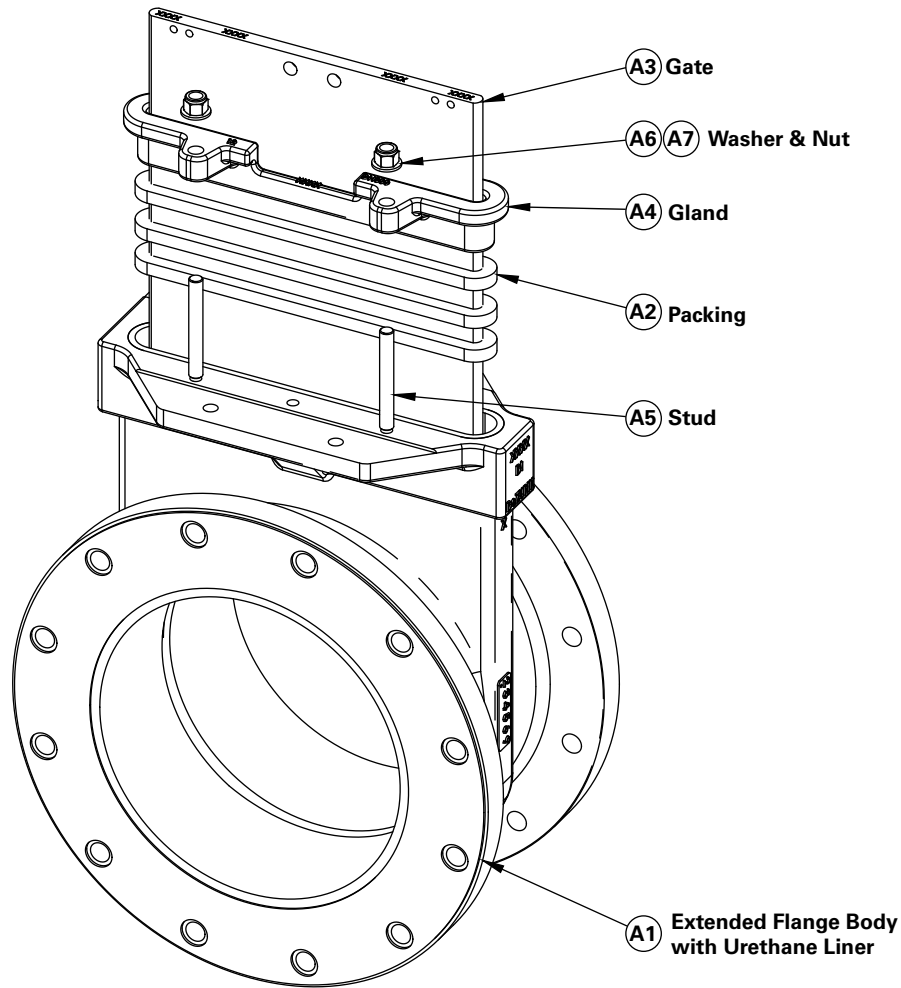

Extended Flanged Body

Valve Selection

Seat/Packing Options

Seat Characteristic	Description	Type	Color	Packing Options	Temperature Range
EU	Urethane, General Water Service	Polyether	Black	SMP, ASP, TDP, NXS	-20 to 175°F (-29 to 79°C)
AUCO	Urethane, Oil Service	Polyester	Clear	SMP, ASP, TDP, NXS	0 to 175°F (-18 to 79°C)
EUCW	Urethane, Water Service	Polyether	Clear	SMP, ASP, TDP, NXS	-20 to 210°F (-29 to 99°C)
AUFO	Urethane, Food Grade Oil Service	Polyester	White	FGP	-20 to 175°F (-29 to 79°C)
EUFW	Urethane, Food Grade Water Service	Polyether	White	FGP	-20 to 175°F (-29 to 79°C)
EUHT	Urethane, High Temp Service	Polyether	Red	SMP, ASP, TDP	-20 to 265°F (-29 to 129°C)
BRPA	Urethane, Phosphoric Acid Service	Polybutadiene	Green	SMP, ASP	5 to 200°F (-15 to 93°C)

NOTE: The limiting factor in valve selection is the lowest temperature component.

Valve Selection

Flow Parameters

Standard and Extended Flanged Valves

Valve Size	Cv* Kv* 100% Open	K** (resistance)	Port Area (in ² /cm ²)
2" 50mm	300 260	0.16	3 20
2.5" 65mm	470 406	0.16	5 32
3" 80mm	675 584	0.16	7 45
4" 100mm	1200 1040	0.16	12 81
5" 125mm	1900 1640	0.16	19 126
6" 150mm	2700 2340	0.16	28 182
8" 200mm	4800 4200	0.16	50 324
10" 250mm	7500 6500	0.16	78 506
12" 300mm	10800 9300	0.16	113 729

Valve Size	Cv* Kv* 100% Open	K** (resistance)	Port Area (in ² /cm ²)
14" 350mm	13200 11400	0.16	137 889
16" 400mm	17400 15100	0.16	182 1178
18" 450mm	22300 19300	0.16	233 1507
20" 500mm	27800 24000	0.16	291 1877
24" 600mm	40500 35000	0.16	424 2739
30" 750mm	64000 55400	0.16	672 4335
36" 900mm	93000 80400	0.16	975 6296
42" 1050mm	126000 109000	0.16	1336 8621
48" 1200mm	165000 142700	0.16	1753 11312

Grooved End Valves

Valve Size	Cv* Kv* 100% Open	K** (resistance)	Port Area (in ² /cm ²)
2" 50mm	220 190	0.44	2.4 16
3" 80mm	530 460	0.36	6 38
4" 100mm	1005 870	0.30	11 69
5" 125mm	1640 1415	0.24	17 110
6" 150mm	2425 2100	0.17	26 168
8" 200mm	3855 3370	0.35	40 259
10" 250mm	6390 540	0.27	67 434
12" 300mm	9490 8175	0.24	99 641

*Cv = Flow in GPM of water at 1 psi pressure drop.
Kv = Flow in m³/hr. of water at 100 kPa pressure drop.
** K = The resistance coefficient of the valve.
The constant (K) can be used to determine the equivalent length of pipe.

$$L = \frac{K \times D}{f} \text{ Where}$$

- L = Equivalent length of pipe in feet
- K = Resistance coefficient
- D = Pipe diameter in feet
- f = Friction factor, related to type of pipe

Applicable Standards

DeZURIK KUL Knife Gate Valves are designed and/or tested to meet the following standards:	
ASME B16.1 (ASA B16.1) 8-24" (200-600mm)	Flanged valves conform to Cast Iron Pipe Flanges and Flanged Fittings, 125 lbs. Conforms to related flange drilling dimensions.
ASME B16.42	Flanged valves conform to Class 150. Conforms to minimum wall thickness 2-24" sizes.
ASME B16.47	Flanged valves conform to Large Diameter Steel Flanges, Series A, 30-48" (750-1200mm) sizes conform to related dimensions.
ASME B16.5 2-6" (50-150mm)	Flanged valves conform to Carbon Steel Flanges and Flanged Fittings, 150 lbs. Conforms to related flange drilling dimensions.
ASME B31.3	Process piping, conforms to allowable stresses and minimum temperature
ANSI/AWWA C606	Grooved Ends conform to standard for Grooved and Shouldered Joints.
International Standards	Flanged valves conform to flanged bolt guides and pressure ratings JIS 10; DIN 10 and DIN 16; ISO 7005-1/PN 10 and 7005-2/PN 16; BS 4504/ PN16; AS2129 table D and E; SANS 1123-1000 and SANS 1123-1600.
MSS SP-81	Flanged valves conform to face-to-face dimensions and pressure rating, 2-24" (50-600mm).
MSS SP-151	Pressure testing of knife gate valves.
SIL	Valves with pneumatic or hydraulic actuators meet IEC 61508SIL3 safety integrity level.

Shut-Off Capabilities

Urethane Seat | Bi-directional leak tight/zero leakage, good for dead-end service.

Pressure Ratings (Ambient Temperatures)

Valve Size	Direct Pressure	Reverse Pressure
2-48" (50-1200mm)	150 or 250 psi CWP 1035 or 1724 kPa CWP	150 or 250 psi CWP 1035 or 1724 kPa CWP

Pressure/Temperature Ratings*

NOTE: *Urethane compound temperature is the limiting factor in valve selection.

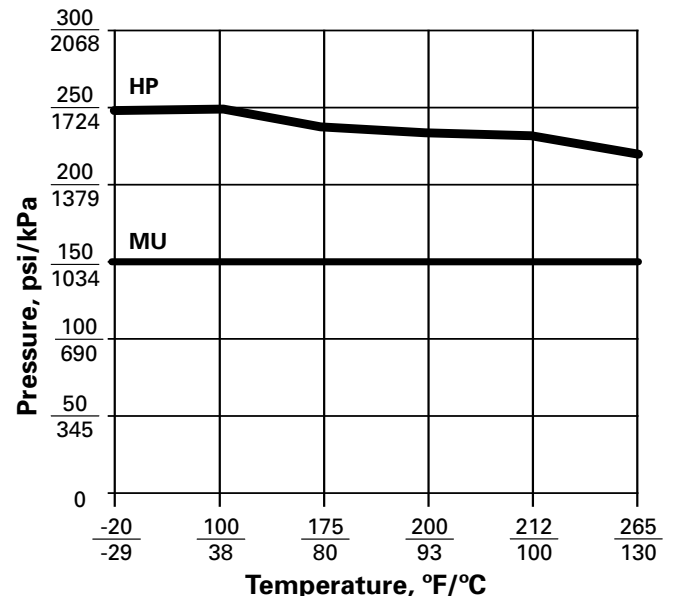

Valve Weights*

Standard Flanged Valves with Manual Actuators

Valve Size	Basic Valve	With Handwheel	With Chainwheel	With Bevel Gear Handwheel		With Bevel Gear Chainwheel	
				Standard & 180°	90° & 270°	Standard & 180°	90° & 270°
2" 50mm	16 8	26 12	38 18	—	—	—	—
2.5" 65mm	22 10	33 15	45 22	—	—	—	—
3" 80mm	22 10	33 15	45 21	94 43	94 43	106 49	106 49
4" 100mm	29 14	43 20	54 25	103 47	103 47	112 51	112 51
5" 125mm	40 19	53 25	67 31	117 54	117 54	124 57	124 57
6" 150mm	45 21	64 30	78 36	122 56	122 56	129 59	129 59
8" 200mm	86 40	107 49	121 55	169 77	169 77	176 80	176 80
10" 250mm	122 56	144 66	178 81	215 98	215 98	223 102	223 102
12" 300mm	179 82	218 99	251 114	274 125	274 125	283 129	283 129
14" 350mm	203 93	267 122	282 128	335 152	385 175	338 154	386 176
16" 400mm	289 132	361 164	390 177	430 196	478 217	432 197	480 218
18" 450mm	397 181	—	—	551 250	599 272	551 250	559 272
20" 500mm	511 232	—	—	679 309	723 329	700 318	748 340
24" 600mm	783 356	—	—	969 440	1017 462	989 449	1037 471
30" 750mm	1563 710	—	—	1755 797	1853 841	1818 825	1915 869
36" 900mm	2440 1108	—	—	2643 1200	2740 1244	2705 1228	2803 1272
42" 1050mm	3929 1783	—	—	4321 1961	4464 2026	4378 1987	4522 2052
48" 1200mm	5449 2473	—	—	6003 2724	6205 2816	6060 2750	6204 2815

lbs. * Weights are approximate and do not include crating.
Kg.

Valve Weights*

Grooved End Valves (Based on V7 Grooved End)

Valve Size	Basic Valve	With Handwheel	With Chainwheel	With Bevel Gear Handwheel		With Bevel Gear Chainwheel		With Pneumatic Cylinder		
				Standard & 180°	90° & 270°	Standard & 180°	90° & 270°	Size	Lbs	Kg
2" 50mm	11 5	21 10	33 15	N/A	N/A	N/A	N/A	4"	26	12
3" 80mm	17 8	28 13	40 18	89 40	89 40	101 46	101 46	4"	32	15
4" 100mm	27 12	41 19	52 24	101 46	101 46	110 50	110 50	4"	48	22
								6"	64	29
5" 125mm	37 17	50 23	64 29	114 52	114 52	121 55	121 55	4"	58	26
								6"	71	32
								8"	83	38
6" 150mm	44 20	63 29	77 35	121 55	121 55	128 58	128 58	4"	68	31
								6"	81	37
								8"	90	41
8" 200mm	77 35	94 43	108 49	156 71	156 71	163 74	163 74	6"	113	51
								8"	124	56
								10"	161	73
10" 250mm	140 64	162 73	196 89	233 106	233 106	241 109	241 109	8"	208	94
								10"	237	108
								12"	267	121
12" 300mm	184 83	223 101	256 116	279 127	279 127	288 131	288 131	8"	255	116
								10"	284	129
								12"	314	142

lbs. * Weights are approximate and do not include crating.
Kg.

Valve Weights*

Extended Flanged Valves with Manual Actuators

Valve Size	Basic Valve	With Handwheel	With Chainwheel	With Bevel Gear Handwheel		With Bevel Gear Chainwheel	
				Standard & 180°	90° & 270°	Standard & 180°	90° & 270°
2" 50mm	23 10	33 15	45 20	N/A	N/A	N/A	N/A
3" 80mm	37 17	48 22	60 27	109 49	109 49	121 55	121 55
4" 100mm	49 22	63 29	74 34	123 56	123 56	132 60	132 60
5" 125mm	61 28	74 34	88 40	138 63	138 63	145 66	145 66
6" 150mm	76 34	95 43	109 49	153 69	153 69	160 73	160 73
8" 200mm	125 57	146 66	160 73	208 94	208 94	215 98	215 98
10" 250mm	189 86	211 96	245 111	282 128	282 128	290 132	290 132
12" 300mm	270 122	309 140	342 155	365 166	365 166	374 170	374 170
14" 350mm	398 181	462 210	477 216	530 240	580 263	533 242	581 264
16" 400mm	537 244	609 276	638 289	678 308	726 329	680 308	728 330
18" 450mm	688 312	N/A	N/A	842 382	890 404	852 386	892 405
20" 500mm	876 397	N/A	N/A	1044 474	1088 494	1065 483	1113 505
24" 600mm	1311 595	N/A	N/A	1497 679	1545 701	1517 688	1565 710
30" 750mm	2448 1110	N/A	N/A	2640 1197	2738 1242	2703 1226	2800 1270
36" 900mm	3876 1758	N/A	N/A	4079 1850	4176 1894	4141 1878	4239 1923
42" 1050mm	5925 2688	N/A	N/A	6317 2865	6460 2930	6374 2891	6518 2957
48" 1200mm	7998 3628	N/A	N/A	8552 3879	8754 3971	8609 3905	8753 3970

lbs.
Kg. * Weights are approximate and do not include crating.

Valve Weights*

Standard Flanged Valves with Cylinder Actuators

Valve Size	With Pneumatic Cylinder		With Hydraulic Cylinder	
	Size	Lbs / Kg	Size	Lbs / Kg
2" 50mm	PC4	31	HC1.5	41
		15		19
2.5" 65mm	PC4	31	HC1.5	53
		15		24
3" 80mm	PC4	31	HC1.5	53
		15		24
4" 100mm	PC4	50	HC2	66
	PC6	23		30
5" 125mm	PC4	61	HC2	78
	PC6	28		
	PC8	34		
6" 150mm	PC4	74	HC2	84
	PC6	38		
	PC8	42		
8" 200mm	PC6	126	HC2	127
	PC8	58		
	PC10	137	HC2.5	137
PC10	63			
10" 250mm	PC8	171	HC2.5	185
	PC10	79		
	PC12	219	HC3.25	194
PC12	100			
12" 300mm	PC8	249	HC2	185
	PC10	113		
	PC12	114	HC2.5	194
PC10	127			
14" 350mm	PC10	309	HC2.5	283
	PC12	141		
	PC12	143	HC4	285
PC12	156			
16" 400mm	PC10	283	HC2.5	389
	PC12	128		
	PC14	313	HC3.25	412
PC14	143			
18" 450mm	PC12	409	HC2.5	515
	PC12	186		
	PC14	439	HC3.25	539
PC14	200			
20" 500mm	PC12	463	HC4	587
	PC14	211		
	PC16	562	HC4	657
PC16	255			
20" 500mm	PC12	586	HC2.5	657
	PC14	266		
	PC16	1071	HC3.25	684
PC16	486			
20" 500mm	PC12	691	HC2.5	736
	PC14	314		
	PC16	987	HC4	334
PC16	448			
20" 500mm	PC12	1310	HC4	334
	PC14	595		
	PC16	595		

Valve Size	With Pneumatic Cylinder		With Hydraulic Cylinder	
	Size	Lbs / Kg	Size	Lbs / Kg
24" 600mm	PC12	964	HC3.5	1031
	PC14	438		
	PC16	988	HC5	1148
	PC18	449		
30" 750mm	PC16	1707	On Application	1934
	PC18	775		
	PC18	1753		
	PC18	796		
36" 900mm	PC18	1753	On Application	1981
	PC18	796		
	PC18	1753		
	PC18	796		
42" 1050mm	PC18	1753	On Application	2046
	PC18	796		
	PC18	1753		
	PC18	796		
48" 1200mm	PC18	1753	On Application	2173
	PC18	796		
	PC18	1753		
	PC18	796		
48" 1200mm	PC18	1753	On Application	3205
	PC18	796		
	PC18	1753		
	PC18	796		
48" 1200mm	PC18	1753	On Application	3205
	PC18	796		
	PC18	1753		
	PC18	796		
48" 1200mm	PC18	1753	On Application	1454
	PC18	796		
	PC18	1753		
	PC18	796		
48" 1200mm	PC18	1753	On Application	5185
	PC18	796		
	PC18	1753		
	PC18	796		
48" 1200mm	PC18	1753	On Application	2352
	PC18	796		
	PC18	1753		
	PC18	796		
48" 1200mm	PC18	1753	On Application	7402
	PC18	796		
	PC18	1753		
	PC18	796		
48" 1200mm	PC18	1753	On Application	3357
	PC18	796		
	PC18	1753		
	PC18	796		

lbs.
Kg. * Weights are approximate and do not include crating.

Valve Weights*

Extended Flange Valves with Pneumatic & Hydraulic Actuators

Valve Size	Valve with Pneumatic Cylinder			Valve with Hydraulic Cylinder		
	Cylinder Size	Weight		Cylinder Size	Weight	
		lb.	kg		lb.	kg
2" 50mm	PC4	38	17	HC1.5	48	22
3" 80mm	PC4	46	21	HC1.5	68	31
4" 100mm	PC4	70	32	HC2	86	39
	PC6	86	39			
5" 125mm	PC4	82	37	HC2	99	45
	PC6	95	43			
	PC8	107	49			
6" 150mm	PC4	100	45	HC2	115	52
	PC6	113	51			
	PC8	122	55			
8" 200mm	PC6	165	75	HC2	166	75
	PC8	176	80	HC2.5	176	80
	PC10	210	95			
10" 250mm	PC8	257	117	HC2	252	114
	PC10	286	130	HC3.25	261	118
	PC12	316	143			
12" 300mm	PC8	341	155	HC2	276	125
	PC10	370	168	HC2.5	285	129
	PC12	400	181	HC3.25	377	171
14" 350mm	PC10	508	230	HC2	478	217
	PC12	538	244	HC2.5	480	218
				HC4	539	244
16" 400mm	PC10	657	298	HC2.5	637	289
	PC12	687	312	HC3.25	660	299
	PC14	711	323	HC4	700	318
18" 450mm	PC12	853	387	HC2.5	806	366
	PC14	877	398	HC3.25	830	376
	PC16	1362	618	HC4	878	398
20" 500mm	PC12	1056	479	HC2.5	1022	464
	PC14	1352	613	HC3.25	1049	476
	PC16	1675	760	HC4	1101	499
24" 600mm	PC12	1492	677	HC3.25	1559	707
	PC14	1516	688	HC4	1563	709
	PC16	2235	1014	HC5	1676	760
30" 750mm	On Application			HC3.25	2819	1279
				HC4	2866	1300
				HC5	2931	1329
HC6				3058	1387	
HC4				4547	2062	
HC5				4641	2105	
HC6				4709	2136	
HC5				7158	3247	
HC6				7181	3257	
HC7				9951	4514	
36" 900mm	On Application					
42" 1050mm						
48" 1200mm						

lbs.
Kg. * Weights are approximate and do not include crating.

Ordering

To order, simply complete the valve order code from information shown. An ordering example is shown for your reference.

Valve Style

Give valve style code as follows:

KUL = Urethane Lined Knife Gate Valve

Valve Size

Give valve size code as follows:

2 = 2" (50mm)	14 = 14" (350mm)
2.5 = 2.5" (65mm)	16 = 16" (400mm)
3 = 3" (80mm)	18 = 18" (450mm)
4 = 4" (100mm)	20 = 20" (500mm)
5 = 5" (125mm)	24 = 24" (600mm)
6 = 6" (150mm)	30 = 30" (750mm)
8 = 8" (200mm)	36 = 36" (900mm)
10 = 10" (250mm)	42 = 42" (1050mm)
12 = 12" (300mm)	48 = 48" (1200mm)

Body Style

Give body style code as follows:

MU = Multi-use to 150 psi (1035 kPa)
 HP = High Pressure to 250 psi (1725 kPa) Must use S5 or S10 gate material.

End Connection

Give end connection code as follows:

F1 = ASME 150 UNC Tapping for Threads
 F110 = ISO 7005/PN10 Drilling*
 F116 = ISO 7005/PN16 Drilling
 F1DA = AS2129 Table D Drilling
 F1EA = AS2129 Table E Drilling
 F1T = ASME 150 Through Bolting
 F1S10 = SANS1123-1000*
 F1S16 = SANS1123-1600
 F1J1 = JIS 10 Drilling (2-36" except 12")
 V7 = Grooved Style 77, for Steel and other metallic pipe per AWWA C606-15, Table 4
 Not available on 2.5" (65mm) valve size
 VF = Grooved Style 31, Flexible joint for ductile iron pipe per AWWA C606-15, Table 2. Not available on 2", 2.5", 3" or 5" (50mm or 125mm) valve sizes
 VR = Grooved Style 31, Rigid joint for ductile iron pipe per AWWA C606-15, Table 3. Not available on 2", 2.5", 3" or 5" (50mm or 125mm) valve sizes

*For use with MU Body Style to 150 psi (1035 kpa) maximum.

Body Material

Give body material code as follows:

DI = Ductile Iron

Packing Material**

Give packing material code as follows:

SMP = PTFE Braided Packing to 500°F (260°C) (pH Range 0-14)
 ASP = Self-Adjusting PTFE Braided Packing with Fluoroelastomer Cord to 400° F (205° C) (pH Range 0-14)
 TDP = Dry Service, Dry PTFE Braided Packing with Solid PTFE Cord to 500°F (260°C) (pH Range: 0-14)
 FGP = Food Grade Service to 450°F (232°C) (pH Range: 3-11)
 Not for use in sanitary valve service
 NXS = NBR X-Cord with PTFE Square Braided Packing Cord to 250°F (120°C).
 Check Chemical Compatibility.

Gate Material

Give gate material code as follows:

S1 = 304 Stainless Steel (MU Body Style) 14" and larger
 S2 = 316 Stainless Steel (MU Body Style)
 S5 = 17-4 Stainless Steel H900 Heat Treated (MU or HP Body Style)
 S6 = 254-SMO Stainless Steel (MU Body Style)
 HC = Hastelloy C (MU Body Style)
 S8 = 410 Stainless Steel (MU Body Style)
 S10 = 2205 Duplex Stainless Steel (MU or HP Body Style)
 S7 = 2507 Super Duplex Stainless Steel (MU or HP Body Style)

Seat Material**

Give seat material code as follows:

EU = Polyether Urethane, Black, Water Service -20 to 175°F (-29 to 80°C)
 AUCCO = Polyester Urethane, Clear, Oil Service 0 to 175°F (-18 to 80°C)
 EUCW = Polyether Urethane, Clear, Water Service -20 to 210°F (-29 to 100°C)
 AUFO = Polyester Urethane, White, Food Grade Oil Service -20 to 175°F (-29 to 80°C)
 EUFW = Polyether Urethane, White, Food Grade Water Service -20 to 175°F (-29 to 80°C)
 EUHT = Polyether Urethane, Red, High Temp Service -20 to 265°F (-29 to 130°C)
 BRPA = Polybutadiene Urethane, Green, Phosphoric Acid Service 5 to 200°F (-15 to 90°C)

Options

Give option code as follows:

EFS = Extended Flange-Short; Face-to-Face equivalent to KSLLA without flange retainers (2-8" Flanged End Connections only)
 EFL = Extended Flange-Long; Face-to-Face equivalent to KSLLA with flange retainers (2-48" Flanged End Connections only)
 CMC = Certificate of Material Conformance
 CRT = Certified Physical and Chemical Test Reports
 DTR = DeZURIK Standard Certified Production Hydrostatic Shell and Seat Test Report
 — = Optional Coating (contact DeZURIK)

Ordering Example:

KUL,6,MU,F1,DI,SMP,S2-EU*actuator

**NOTE: The urethane seat material temperature is the limiting factor in valve selection.

Manual Actuators

Handwheel and Chainwheel Actuators

All 2-16" (50-400mm) valves can be furnished with handwheel actuators or chainwheel actuators. To order handwheel or chainwheel actuators, add the appropriate order code to the basic valve order code. Refer to information on bevel gear actuators for use on dry solids, paper stock, slurries or when pressure exceeds limits shown. Order chain for chainwheel actuators as a separate item.

Handwheel Actuator

Valve Size	Order Code	Order Code	Maximum Pressure Differential psi/kPa
	Carbon Steel (CS) Yoke	304 SST (S1) Yoke	
2" & 2.5" 50mm & 65mm	MN-HD8-CS	MN-HD8-S1	250 1725
	MN-HD8-CS	MN-HD8-S1	250 1725
3" 80mm	MN-HD12-CS	MN-HD12-S1	250 1725
	MN-HD12-CS	MN-HD12-S1	250 1725
4" 100mm	MN-HD12-CS	MN-HD12-S1	150 1035
	MN-HD16-CS	MN-HD16-S1	250 1725
5" 125mm	MN-HD12-CS	MN-HD12-S1	150 1035
	MN-HD16-CS	MN-HD16-S1	250 1725
6" 150mm	MN-HD12-CS	MN-HD12-S1	150 1035
	MN-HD16-CS	MN-HD16-S1	250 1725
8" 200mm	MN-HD16-CS	MN-HD16-S1	250 1725
	MN-HD16-CS	MN-HD16-S1	150 1035
10" 250mm	MN-HD16-CS	MN-HD16-S1	150 1035
	MN-HD16-CS	MN-HD16-S1	150 1035
12" 300mm	MN-HD16-CS	MN-HD16-S1	100 690
	MN-HD20-CS	MN-HD20-S1	75 518
14" 350mm	MN-HD20-CS	MN-HD20-S1	100 690
	MN-HD20-CS	MN-HD20-S1	75 518
16" 400mm	MN-HD20-CS	MN-HD20-S1	75 518
	MN-HD20-CS	MN-HD20-S1	75 518

NOTE: The limiting factor in actuator selection is the lowest pressure rating of the valve or actuator.

Bevel gear actuators recommended for dry solids, paper stocks, slurries, or when pressure exceeds limits shown.

Ordering Example:

KUL,6,MU,F1,DI,SMPS1-EU*MN-HD12-CS

Chainwheel Actuator

Valve Size	Order Code	Order Code	Maximum Pressure Differential psi/kPa
	Carbon Steel (CS) Yoke	304 SST (S1) Yoke	
2" & 2.5" 50mm & 65mm	MN-CW8-CS	MN-CW8-S1	250 1725
	MN-CW8-CS	MN-CW8-S1	250 1725
3" 80mm	MN-CW8-CS	MN-CW8-S1	250 1725
	MN-CW12-CS	MN-CW12-S1	250 1725
4" 100mm	MN-CW12-CS	MN-CW12-S1	250 1725
	MN-CW12-CS	MN-CW12-S1	150 1035
5" 125mm	MN-CW12-CS	MN-CW12-S1	150 1035
	MN-CW20-CS	MN-CW20-S1	250 1725
6" 150mm	MN-CW20-CS	MN-CW20-S1	250 1725
	MN-CW20-CS	MN-CW20-S1	150 1035
8" 200mm	MN-CW20-CS	MN-CW20-S1	150 1035
	MN-CW20-CS	MN-CW20-S1	100 690
10" 250mm	MN-CW20-CS	MN-CW20-S1	100 690
	MN-CW20-CS	MN-CW20-S1	100 690
12" 300mm	MN-CW20-CS	MN-CW20-S1	150 1035
	MN-CW30-CS	MN-CW30-S1	150 1035
14" 350mm	MN-CW30-CS	MN-CW30-S1	100 690
	MN-CW30-CS	MN-CW30-S1	100 690
16" 400mm	MN-CW30-CS	MN-CW30-S1	100 690
	MN-CW30-CS	MN-CW30-S1	100 690

NOTE: The limiting factor in actuator selection is the lowest pressure rating of the valve or actuator.

Bevel gear actuators recommended for dry solids, paper stocks, slurries, or when pressure exceeds limits shown.

Ordering Example:

KUL,6,MU,F1,DI,SMPS1-EU*MN-CW20-CS

Nut Actuators

Nut actuators are available when the ENTS extension is ordered on Flanged Valves.

Nut Actuator

Valve Size	Order Code	Order Code	Maximum Pressure Differential psi/kPa
	Carbon Steel (CS) Yoke	304 SST (S1) Yoke	
2" & 2.5" 50mm & 65mm	MN-N-CS	MN-N-S1	250 1725
	MN-N-CS	MN-N-S1	250 1725
3" 80mm	MN-N-CS	MN-N-S1	250 1725
	MN-N-CS	MN-N-S1	250 1725
4" 100mm	MN-N-CS	MN-N-S1	250 1725
	MN-N-CS	MN-N-S1	250 1725
5" 125mm	MN-N-CS	MN-N-S1	250 1725
	MN-N-CS	MN-N-S1	250 1725
6" 150mm	MN-N-CS	MN-N-S1	250 1725
	MN-N-CS	MN-N-S1	250 1725
8" 200mm	MN-N-CS	MN-N-S1	250 1725
	MN-N-CS	MN-N-S1	250 1725
10" 250mm	MN-N-CS	MN-N-S1	250 1725
	MN-N-CS	MN-N-S1	250 1725

Valve Size	Order Code	Order Code	Maximum Pressure Differential psi/kPa
	Carbon Steel (CS) Yoke	304 SST (S1) Yoke	
12" 300mm	MN-N-CS*	MN-N-S1*	250 1725
	MN-N-CS*	MN-N-S1*	250 1725
14" 350mm	MN-N-CS*	MN-N-S1*	150 1035
	MN-N-CS*	MN-N-S1*	150 1035
16" 400mm	MN-N-CS*	MN-N-S1*	150 1035
	MN-N-CS*	MN-N-S1*	150 1035

NOTE: The limiting factor in Actuator Selection is the lowest pressure rating of the valve or actuator.

Bevel gear actuators recommended for dry solids, paper stock, slurries, or when pressure exceeds limits shown.

Ordering Example:

KUL,4,MU,F1,DI,SMPS1-EU*MN-N-CS,ENTS

Manual Actuators

Bevel Gear Actuators

Bevel Gear Actuators are available on 2-48" (50-1200mm) valves with handwheel or chainwheel actuators. Bevel Gear Actuators provide vertical mounting of the handwheel or chainwheel, or can be used where space limitations prohibit the use of a standard handwheel or chainwheel. A mechanical advantage makes large valve operation easier and faster.

Bevel Gear Handwheel Actuators

Valve Size	Order Code Carbon Steel (CS) Yoke	Order Code 304 SST (S1) Yoke	Maximum Pressure Differential psi/kPa
3" 80mm	MNB-HD12-CS	MNB-HD12-S1	250 1725
4" 100mm	MNB-HD12-CS	MNB-HD12-S1	250 1725
5" 125mm	MNB-HD12-CS	MNB-HD12-S1	250 1725
6" 150mm	MNB-HD12-CS	MNB-HD12-S1	250 1725
8" 200mm	MNB-HD12-CS	MNB-HD12-S1	250 1725
10" 250mm	MNB-HD12-CS	MNB-HD12-S1	150 1035
	MNB-HD16-CS	MNB-HD16-S1	250 1725
12" 300mm	MNB-HD12-CS	MNB-HD12-S1	150 1035
	MNB-HD16-CS	MNB-HD16-S1	250 1725
14" 350mm	MNB-HD12-CS	MNB-HD12-S1	150 1035
	MNB-HD16-CS	MNB-HD16-S1	250 1725
16" 400mm	MNB-HD16-CS	MNB-HD16-S1	150 1035
	MNB-HD24-CS	MNB-HD24-S1	250 1725
18" 450mm	MNB-HD24-CS	MNB-HD24-S1	150 1035
	MNB-HD30-CS	MNB-HD30-S1	250 1725
20" 500mm	MNB-HD24-CS	MNB-HD24-S1	150 1035
	MNB-HD36-CS	MNB-HD36-S1	250 1725
24" 600mm	MNB-HD24-CS	MNB-HD24-S1	250 1725
30" 750mm	MNB-HD24-CS	MNB-HD24-S1	250 1725
36" 900mm	MNB-HD24-CS	MNB-HD24-S1	250 1725
42" 1050mm	MNB-HD24-CS	MNB-HD24-S1	150 1035
	MNB-HD30-CS	MNB-HD30-S1	250 1725
48" 1200mm	MNB-HD24-CS	MNB-HD24-S1	150 1035
	MNB-HD30-CS	MNB-HD30-S1	250 1725

NOTE: The limiting factor in actuator selection is the lowest pressure rating of the valve or actuator.

Ordering Example:

KUL,6,MU,F1,DI,SM,PS1-EU*MNB-HD12-CS

For alternate mounting of bevel gear actuators, add -90, -180 or -270 after the actuator code and as 2nd line information on the order.

Bevel Gear Chainwheel Actuators

Valve Size	Order Code Carbon Steel (CS) Yoke	Order Code 304 SST (S1) Yoke	Maximum Pressure Differential psi/kPa
3" 80mm	MNB-CW12-CS	MNB-CW12-S1	250 1725
4" 100mm	MNB-CW12-CS	MNB-CW12-S1	250 1725
5" 125mm	MNB-CW12-CS	MNB-CW12-S1	250 1725
6" 150mm	MNB-CW12-CS	MNB-CW12-S1	250 1725
8" 200mm	MNB-CW12-CS	MNB-CW12-S1	250 1725
10" 250mm	MNB-CW12-CS	MNB-CW12-S1	150 1035
	MNB-CW20-CS	MNB-CW20-S1	250 1725
12" 300mm	MNB-CW12-CS	MNB-CW12-S1	150 1035
	MNB-CW20-CS	MNB-CW20-S1	250 1725
14" 350mm	MNB-CW12-CS	MNB-CW12-S1	150 1035
	MNB-CW20-CS	MNB-CW20-S1	250 1725
16" 400mm	MNB-CW20-CS	MNB-CW20-S1	150 1035
	MNB-CW30-CS	MNB-CW30-S1	250 1725
18" 450mm	MNB-CW30-CS	MNB-CW30-S1	250 1725
20" 500mm	MNB-CW30-CS	MNB-CW30-S1	250 1725
24" 600mm	MNB-CW20-CS	MNB-CW20-S1	150 1035
	MNB-CW30-CS	MNB-CW30-S1	250 1725
30" 750mm	MNB-CW20-CS	MNB-CW20-S1	150 1035
	MNB-CW30-CS	MNB-CW30-S1	250 1725
36" 900mm	MNB-CW30-CS	MNB-CW30-S1	250 1725
42" & 48" 1050-1200mm	MNB-CW30-CS	MNB-CW30-S1	250 1725

NOTE: The limiting factor in actuator selection is the lowest pressure rating of the valve or actuator.

Ordering Example:

KUL,14,MU,F1,DI,SM,PS1-EU*MNB-CW12-CS-90

Actuator mounted at 90 degrees

Manual Actuator Accessories

Chain for Chainwheel Actuators

Order as a separate item by giving the correct code and specify required length of chain as second line information. One closing link is supplied with the chainwheel actuator.

Order Code	Description
ACC*CN102	Steel, Zinc Plated 3/16
ACC*CN103	Galvanized 3/16
ACC*CN106	316 Stainless Steel 3/16

Ordering Example:

ACC*CN102

Chain 12 feet long (366cm)

Lockout Device

Available on all sizes of handwheel and bevel gear handwheel actuated valves. To order, add a comma and the order code "LK" after the actuator code.

Ordering Example:

KUL,6,MU,F1,DI,SMP,S1-EU*MN-HD12-S1,LK

Extension for Handwheel or 2" Nut Extension

Provides extension of the handwheel or nut to allow remote operation – normally from above. The extension includes fittings and extension pipe with handwheel or nut mounted. To order, specify description and extension length from center line of valve to handwheel or nut.

Order Code	Description
ENHD	Extension for Handwheel
ENTS	Extension for Nut

Ordering Example:

KUL,6,MN,F1,DI,SMP,S1-EU*MN-N-S1,ENTS

Center line of valve to top of nut 72 inches (1829mm).

Cylinder Actuators

Double Acting Pneumatic Cylinder Actuators for on/off or positioning services are sized for supply pressures of 60 or 80 psi (410 or 550 kPa). To order, add the proper code from the table to the valve order code.

Pneumatic Actuator Sizing

60 psi (410 kPa) Air Supply

Valve Size	Order Code	Order Code	Maximum Pressure Differential psi/kPa	
	Carbon Steel (CS) Yoke	304 SST (S1) Yoke	Dry Solids, Slurries, Paper Stock	Liquids & Gases
2" & 2.5" 50mm & 65mm	CY-PC4-CS	CY-PC4-S1	250 1725	250 1725
	CY-PC4-CS	CY-PC4-S1	250 1725	250 1725
3" 80mm	CY-PC4-CS	CY-PC4-S1	100 690	150 1035
	CY-PC6-CS	CY-PC6-S1	250 1725	250 1725
4" 100mm	CY-PC4-CS	CY-PC4-S1	N/A	50 345
	CY-PC6-CS	CY-PC6-S1	100 690	150 1035
	CY-PC8-CS	CY-PC8-S1	250 1725	250 1725
5" 125mm	CY-PC4-CS	CY-PC4-S1	N/A	50 345
	CY-PC6-CS	CY-PC6-S1	100 690	150 1035
	CY-PC8-CS	CY-PC8-S1	250 1725	250 1725
6" 150mm	CY-PC4-CS	CY-PC4-S1	N/A	50 345
	CY-PC6-CS	CY-PC6-S1	100 690	150 1035
	CY-PC8-CS	CY-PC8-S1	250 1725	250 1725
8" 200mm	CY-PC6-CS	CY-PC6-S1	100 690	150 1035
	CY-PC8-CS	CY-PC8-S1	200 1380	250 1725
	CY-PC10-CS	CY-PC10-S1	250 1725	N/R
10" 250mm	CY-PC8-CS	CY-PC8-S1	75 518	100 690
	CY-PC10-CS	CY-PC10-S1	200 1380	250 1725
	CY-PC12-CS	CY-PC12-S1	250 1725	N/R
12" 300mm	CY-PC8-CS	CY-PC8-S1	75 518	100 690
	CY-PC10-CS	CY-PC10-S1	150 1035	200 1380
	CY-PC12-CS	CY-PC12-S1	250 1725	250 1725
14" 350mm	CY-PC10-CS	CY-PC10-S1	100 690	150 1035
	CY-PC12-CS	CY-PC12-S1	250 1725	250 1725
16" 400mm	CY-PC10-CS	CY-PC10-S1	75 518	100 690
	CY-PC12-CS	CY-PC12-S1	100 690	150 1035
	CY-PC14-CS	CY-PC14-S1	250 1725	250 1725

Valve Size	Order Code	Order Code	Maximum Pressure Differential psi/kPa	
	Carbon Steel (CS) Yoke	304 SST (S1) Yoke	Dry Solids, Slurries, Paper Stock	Liquids & Gases
18" 450mm	CY-PC12-CS	CY-PC12-S1	75 518	100 690
	CY-PC14-CS	CY-PC14-S1	200 1380	250 1725
	CY-PC16-CS	CY-PC16-S1	250 1725	N/R
20" 500mm	CY-PC12-CS	CY-PC12-S1	50 345	75 518
	CY-PC14-CS	CY-PC14-S1	100 690	150 1035
	CY-PC16-CS	CY-PC16-S1	250 1725	250 1725
24" 600mm	CY-PC14-CS	CY-PC14-S1	75 518	100 690
	CY-PC16-CS	CY-PC16-S1	150 1035	200 1380
	CY-PC18-CS	CY-PC18-S1	250 1725	250 1725
30" 750mm	Contact DeZURIK for cylinder actuator sizing.			
36" 900mm				
42" 1050mm				
48" 1200mm				

NOTE: The limiting factor in actuator selection is the lowest pressure rating of the valve or actuator.

N/R = Not required. Use next smaller actuator.

N/A = Not available. Use larger actuator or contact DeZURIK.

For alternate mounting, add -90, -180 or -270 after the actuator code and as a second line information on the order.

Cylinder Actuators

Pneumatic Actuator Sizing

80 psi (550 kPa) Air Supply

Valve Size	Order Code	Order Code	Maximum Pressure Differential psi/kPa	
	Carbon Steel (CS) Yoke	304 SST (S1) Yoke	Dry Solids, Slurries, Paper Stock	Liquids & Gases
2" & 2.5" 50mm & 65mm	CY-PC4-CS	CY-PC4-S1	250 1725	250 1725
	CY-PC4-CS	CY-PC4-S1	250 1725	250 1725
3" 80mm	CY-PC4-CS	CY-PC4-S1	150 1035	200 1380
	CY-PC6-CS	CY-PC6-S1	250 1725	250 1725
4" 100mm	CY-PC4-CS	CY-PC4-S1	50 345	75 518
	CY-PC6-CS	CY-PC6-S1	200 1380	250 1725
	CY-PC8-CS	CY-PC8-S1	250 1725	N/R
5" 125mm	CY-PC4-CS	CY-PC4-S1	50 345	75 518
	CY-PC6-CS	CY-PC6-S1	150 1035	200 1380
	CY-PC8-CS	CY-PC8-S1	250 1725	250 1725
6" 150mm	CY-PC6-CS	CY-PC6-S1	100 690	150 1035
	CY-PC8-CS	CY-PC8-S1	250 1725	250 1725
	CY-PC10-CS	CY-PC10-S1	250 1725	250 1725
8" 200mm	CY-PC8-CS	CY-PC8-S1	100 690	150 1035
	CY-PC10-CS	CY-PC10-S1	250 1725	250 1725
10" 250mm	CY-PC8-CS	CY-PC8-S1	100 690	150 1035
	CY-PC10-CS	CY-PC10-S1	200 1380	250 1725
	CY-PC12-CS	CY-PC12-S1	250 1725	N/R
12" 300mm	CY-PC10-CS	CY-PC10-S1	100 690	150 1035
	CY-PC12-CS	CY-PC12-S1	250 1725	250 1725
14" 350mm	CY-PC10-CS	CY-PC10-S1	75 518	100 690
	CY-PC12-CS	CY-PC12-S1	200 1380	250 1725
	CY-PC14-CS	CY-PC14-S1	250 1725	N/R
16" 400mm	CY-PC12-CS	CY-PC12-S1	200 1380	250 1725
	CY-PC14-CS	CY-PC14-S1	250 1725	N/R
18" 450mm	CY-PC12-CS	CY-PC12-S1	250 1725	N/R
	CY-PC14-CS	CY-PC14-S1	250 1725	N/R

NOTE: The limiting factor in actuator selection is the lowest pressure rating of the valve or actuator.

N/R = Not required. Use next smaller actuator.
N/A = Not available. Use larger actuator or contact DeZURIK.

For alternate mounting, add -90, -180 or -270 after the actuator code and as a second line information on the order.

Valve Size	Order Code	Order Code	Maximum Pressure Differential psi/kPa	
	Carbon Steel (CS) Yoke	304 SST (S1) Yoke	Dry Solids, Slurries, Paper Stock	Liquids & Gases
20" 500mm	CY-PC12-CS	CY-PC12-S1	75 518	100 690
	CY-PC14-CS	CY-PC14-S1	200 1380	250 1725
	CY-PC16-CS	CY-PC16-S1	250 1725	N/R
24" 600mm	CY-PC12-CS	CY-PC12-S1	50 345	100 690
	CY-PC14-CS	CY-PC14-S1	150 1035	250 1725
	CY-PC16-CS	CY-PC16-S1	250 1725	N/R
30" 750mm	Contact DeZURIK for cylinder actuator sizing.			
36" 900mm				
42" 1050mm				
48" 1200mm				

Hydraulic Cylinder Actuators

Double Acting Hydraulic cylinders for on/off operation are sized for 1000 and 2000 psig (6900 and 13790 kPa) slurry service with a 2:1 safety factor capable of maximum non-shock pressure. Contact DeZURIK Application Engineering for Dry

Service applications. All actuators are sized to the full pressure rating of the valve. Specify hydraulic media if other than oil. To order, add the proper code from the table to the valve order code.

Hydraulic Cylinder Actuators

1000 psi (6900 kPa) Supply

Valve Size	Order Code		Maximum Pressure Differential psi/kPa
	Carbon Steel (CS) Yoke	304 SST (S1) Yoke	
2" 50mm	CY-HC1.5-CS	CY-HC1.5-S1	250 1724
2.5" 65mm	CY-HC1.5-CS	CY-HC1.5-S1	250 1724
3" 80mm	CY-HC1.5-CS	CY-HC1.5-S1	250 1724
4" 100mm	CY-HC2-CS	CY-HC2-S1	250 1724
5" 125mm	CY-HC2-CS	CY-HC2-S1	250 1724
6" 150mm	CY-HC2-CS	CY-HC2-S1	250 1724
8" 200mm	CY-HC2-CS	CY-HC2-S1	150 1034
	CY-HC2.5-CS	CY-HC2.5-S1	250 1724
10" 250mm	CY-HC2-CS	CY-HC2-S1	150 1034
	CY-HC3.25-CS	CY-HC3.25-S1	250 1724
12" 300mm	CY-HC2.5-CS	CY-HC2.5-S1	150 1034
	CY-HC3.25-CS	CY-HC3.25-S1	250 1724
14" 350mm	CY-HC2.5-CS	CY-HC2.5-S1	150 1034
	CY-HC4-CS	CY-HC4-S1	250 1724
16" 400mm	CY-HC3.25-CS	CY-HC3.25-S1	150 1034
	CY-HC4-CS	CY-HC4-S1	250 1724
18" 450mm	CY-HC3.25-CS	CY-HC3.25-S1	150 1034
	CY-HC4-CS	CY-HC4-S1	250 1724
20" 500mm	CY-HC3.25-CS	CY-HC3.25-S1	150 1034
	CY-HC4-CS	CY-HC4-S1	250 1724
24" 600mm	CY-HC4-CS	CY-HC4-S1	150 1034
	CY-HC5-CS	CY-HC5-S1	250 1724
30" 750mm	CY-HC5-CS	CY-HC5-S1	150 1034
	CY-HC6-CS	CY-HC6-S1	250 1724
36" 900mm	CY-HC5-CS	CY-HC5-S1	150 1034
42" 1050mm	CY-HC6-CS	CY-HC6-S1	150 1034
48" 1200mm	CY-HC7-CS	CY-HC7-S1	150 1034

2000 psi (13790 kPa) Supply

Valve Size	Order Code		Maximum Pressure Differential psi/kPa
	Carbon Steel (CS) Yoke	304 SST (S1) Yoke	
2" 50mm	CY-HC1.5-CS	CY-HC1.5-S1	250 1724
2.5" 65mm	CY-HC1.5-CS	CY-HC1.5-S1	250 1724
3" 80mm	CY-HC1.5-CS	CY-HC1.5-S1	250 1724
4" 100mm	CY-HC2-CS	CY-HC2-S1	250 1724
5" 125mm	CY-HC2-CS	CY-HC2-S1	250 1724
6" 150mm	CY-HC2-CS	CY-HC2-S1	250 1724
8" 200mm	CY-HC2-CS	CY-HC2-S1	250 1724
10" 250mm	CY-HC2-CS	CY-HC2-S1	250 1724
12" 300mm	CY-HC2-CS	CY-HC2-S1	150 1034
	CY-HC2.5-CS	CY-HC2.5-S1	250 1724
14" 350mm	CY-HC2-CS	CY-HC2-S1	150 1034
	CY-HC2.5-CS	CY-HC2.5-S1	250 1724
16" 400mm	CY-HC2.5-CS	CY-HC2.5-S1	250 1724
18" 450mm	CY-HC2.5-CS	CY-HC2.5-S1	250 1724
20" 500mm	CY-HC2.5-CS	CY-HC2.5-S1	150 1034
	CY-HC3.25-CS	CY-HC3.25-S1	250 1724
24" 600mm	CY-HC3.25-CS	CY-HC3.25-S1	250 1724
30" 750mm	CY-HC3.25-CS	CY-HC3.25-S1	150 1034
	CY-HC4-CS	CY-HC4-S1	250 1724

Hydraulic Cylinder Actuators

Swept Volume

Valve Size	Order Code		Hydraulic Cylinder Diameter inch cm	Area		Swept Volume	
	Carbon Steel (CS) Yoke	304 SST (S1) Yoke		inch ² cm ²		inch ³ cm ³	
				Open	Close	Open	Close
2" 50mm	CY-HC1.5-CS	CY-HC1.5-S1	1.5	1.0	1.8	2	4
			3.8	6.3	11.4	33	60
2.5" 65mm	CY-HC1.5-CS	CY-HC1.5-S1	1.5	1.0	1.8	3	5
			3.8	6.3	11.4	42	76
3" 80mm	CY-HC1.5-CS	CY-HC1.5-S1	1.5	1.0	1.8	3	6
			3.8	6.3	11.4	51	91
4" 100mm	CY-HC2-CS	CY-HC2-S1	2.0	2.4	3.1	10	13
			5.1	15.2	20.3	160	213
5" 125mm	CY-HC2-CS	CY-HC2-S1	2.0	2.4	3.1	12	16
			5.1	15.2	20.3	198	265
6" 150mm	CY-HC2-CS	CY-HC2-S1	2.0	2.4	3.1	15	19
			5.1	15.2	20.3	238	318
8" 200mm	CY-HC2-CS	CY-HC2-S1	2.0	2.4	3.1	19	26
			5.1	15.2	20.3	318	424
	CY-HC2.5-CS	CY-HC2.5-S1	2.5	3.4	4.9	28	40
10" 250mm	CY-HC2-CS	CY-HC2-S1	2.0	2.4	3.1	24	32
			5.1	15.2	20.3	397	530
	CY-HC3.25-CS	CY-HC3.25-S1	3.25	6.8	8.3	70	85
12" 300mm	CY-HC2-CS	CY-HC2-S1	2.0	2.4	3.1	29	39
			5.1	15.2	20.3	478	637
	CY-HC2.5-CS	CY-HC2.5-S1	2.5	3.4	4.9	42	61
14" 350mm	CY-HC2-CS	CY-HC2-S1	2.0	2.4	3.1	29	39
			5.1	15.2	20.3	478	637
	CY-HC3.25-CS	CY-HC3.25-S1	3.25	6.8	8.3	84	103
16" 400mm	CY-HC2-CS	CY-HC2-S1	2.0	2.4	3.1	32	43
			5.1	15.2	20.3	525	700
	CY-HC2.5-CS	CY-HC2.5-S1	2.5	3.4	4.9	47	67
18" 450mm	CY-HC4-CS	CY-HC4-S1	4.0	10.2	12.6	138	171
			10.2	65.6	81.1	2265	2801
	CY-HC2.5-CS	CY-HC2.5-S1	2.5	3.4	4.9	54	77
20" 500mm	CY-HC2.5-CS	CY-HC2.5-S1	2.5	3.4	4.9	54	77
			6.4	22.1	31.7	879	1260
	CY-HC3.25-CS	CY-HC3.25-S1	3.25	6.8	8.3	107	130
24" 600mm	CY-HC4-CS	CY-HC4-S1	4.0	10.2	12.6	159	197
			10.2	65.6	81.1	2608	3225
	CY-HC3.25-CS	CY-HC3.25-S1	3.25	6.8	8.3	1748	2129
30" 750mm	CY-HC4-CS	CY-HC4-S1	4.0	10.2	12.6	180	223
			10.2	65.6	81.1	2956	3655
	CY-HC2.5-CS	CY-HC2.5-S1	2.5	3.4	4.9	61	87
36" 900mm	CY-HC5-CS	CY-HC5-S1	5.0	16.5	19.6	996	1428
			12.7	106.4	126.7	6443	7671
	CY-HC3.25-CS	CY-HC3.25-S1	3.25	6.8	8.3	121	147
42" 1050mm	CY-HC5-CS	CY-HC5-S1	5.0	16.5	19.6	121	147
			12.7	106.4	126.7	1981	2413
	CY-HC4-CS	CY-HC4-S1	4.0	10.2	12.6	180	223
48" 1200mm	CY-HC6-CS	CY-HC6-S1	6.0	23.4	28.3	2956	3655
			15.2	150.7	182.4	6443	7671
	CY-HC3.25-CS	CY-HC3.25-S1	3.25	6.8	8.3	162	198
50mm	CY-HC4-CS	CY-HC4-S1	4.0	10.2	12.6	162	198
			10.2	65.6	81.1	2661	3241
	CY-HC5-CS	CY-HC5-S1	5.0	16.5	19.6	242	300
750mm	CY-HC5-CS	CY-HC5-S1	5.0	16.5	19.6	242	300
			12.7	106.4	126.7	3970	4909
	CY-HC6-CS	CY-HC6-S1	6.0	23.4	28.3	393	468
900mm	CY-HC6-CS	CY-HC6-S1	6.0	23.4	28.3	468	590
			15.2	150.7	182.4	6443	7671
	CY-HC4-CS	CY-HC4-S1	4.0	10.2	12.6	5007	6192
1050mm	CY-HC5-CS	CY-HC5-S1	5.0	16.5	19.6	205	249
			12.7	106.4	126.7	3356	4088
	CY-HC6-CS	CY-HC6-S1	6.0	23.4	28.3	306	378
1200mm	CY-HC6-CS	CY-HC6-S1	6.0	23.4	28.3	306	378
			15.2	150.7	182.4	5007	6192
	CY-HC5-CS	CY-HC5-S1	5.0	16.5	19.6	590	712
1500mm	CY-HC5-CS	CY-HC5-S1	5.0	16.5	19.6	590	712
			12.7	106.4	126.7	9798	11664
	CY-HC6-CS	CY-HC6-S1	6.0	23.4	28.3	847	1025
1800mm	CY-HC6-CS	CY-HC6-S1	6.0	23.4	28.3	847	1025
			15.2	150.7	182.4	13880	16796
	CY-HC5-CS	CY-HC5-S1	5.0	16.5	19.6	697	830
2100mm	CY-HC6-CS	CY-HC6-S1	6.0	23.4	28.3	697	830
			15.2	150.7	182.4	11422	13598
	CY-HC7-CS	CY-HC7-S1	7.0	31.4	38.5	987	1195
2400mm	CY-HC7-CS	CY-HC7-S1	7.0	31.4	38.5	987	1195
			17.8	202.7	248.3	16181	19580
	CY-HC5-CS	CY-HC5-S1	5.0	16.5	19.6	797	949
2700mm	CY-HC5-CS	CY-HC5-S1	5.0	16.5	19.6	797	949
			12.7	106.4	126.7	13063	15551
	CY-HC7-CS	CY-HC7-S1	7.0	31.4	38.5	1518	1860
3000mm	CY-HC7-CS	CY-HC7-S1	7.0	31.4	38.5	1518	1860
			17.8	202.7	248.3	24881	30479

Cylinder Actuator Accessories

Positioners

DeZURIK Cylinder Actuators are available with pneumatic, electro-pneumatic or digital positioners. Positioners are available in various NEMA ratings and mounted to the actuator legs.

Air Filter Regulator

The DeZURIK Air Filter Regulator is designed to provide clean, accurate air pressure to actuators and positioners.

Four-Way Solenoid Valves

Solenoid Valves may be ordered mounted and piped as part of a complete valve/actuator assembly or as a separate item.

Speed Control Valves

Speed Control Valves are available for controlling valve opening or closing speed with pneumatic actuators. The speed of operation is adjustable.

Position Indicating Switches

Mechanical or Proximity Position Indicating Switches are available for use on double-acting cylinder actuators. One switch can be set to indicate open or closed position. Two switches will automatically be set to indicate full open and full closed positions.

Corrosion Resistant Cylinder

The Corrosion Resistant Cylinder assembly includes epoxy coating on the head, cap and gland – all of which are cast iron. The tube is fiberglass and all fasteners are stainless steel. To order Corrosion-Resistant Cylinder construction, add -CR to the actuator code.

Ordering Example:

KUL,6,MU,F1,DI,SMP,S1-EU*CY-PC6-S1-CR

Electric Motor Actuators

DeZURIK Knife Gate Valves can be furnished with electric motor actuators including Limitorque, Auma, Rotork, E.I.M. and others.

When ordering Electric Motor Actuators, specify valve order code, shutoff pressure, service conditions (flowing media and installation direction); type of application (on/off or throttling); speed of operation; NEMA rating (4, 7, submersible, etc.); electrical characteristics (voltage and phase); actuator accessories and controls as per specification requirements.

High-Strength Actuator Legs

For unsupported horizontal mounting of 3-12" (80-300mm) valve sizes with cylinder actuators, High-Strength Actuator Legs are available as part of a complete valve and actuator assembly. To order, add the SAL code after the actuator code.

Ordering Example:

KUL,6,MU,F1,DI,SMP,S1-EU*CY-PC6-S1,SAL

Stem Cover Bellows

To protect valve stem from environmental debris, the Stem Cover Bellows may be ordered as part of a complete valve and cylinder actuator assembly. To order, add the SCB code to the valve and actuator code.

Ordering Example:

KUL,6,MU,F1,DI,SMP,S1-EU*CY-PC6-S1,SCB

Lockout Device

Available on all sizes of Cylinder Actuated Valves. To order, add the LK code to the valve and actuator code.

Ordering Example:

KUL,6,MU,F1,DI,SMP,S1-EU*CY-PC6-S1,LK

Stainless Steel Tubing and Fittings

To order accessories piped with stainless steel tubing and fittings, add -SF to the order code.

Dimensions

Standard Flanged Valve and Nut

Valve Size	Dimensions				
	F	G	H	L	M
2" 50mm	3.25 83	1.88 48	4.00 102	22.44 570	17.63 448
2.5" 65mm	3.64 92	2.00 51	4.75 121	25.60 650	19.79 503
3" 80mm	3.75 95	2.00 51	4.75 121	25.92 658	20.11 511
4" 100mm	4.50 114	2.00 51	5.00 127	28.20 716	23.39 594
5" 125mm	5.00 127	2.25 57	5.75 146	32.62 829	27.81 706
6" 150mm	5.50 140	2.25 57	5.75 146	34.20 869	29.39 747
8" 200mm	6.75 171	2.75 70	6.38 162	39.70 1008	34.89 886
10" 250mm	8.00 203	2.75 70	8.25 210	46.53 1182	41.72 1060
12" 300mm	9.50 241	3.00 76	8.25 210	52.19 1326	47.38 1203
14" 350mm	10.50 267	3.00 76	8.25 210	63.19 1605	58.38 1483
16" 400mm	11.75 298	3.50 89	8.69 221	70.63 1794	65.82 1672

Inches
Millimeters

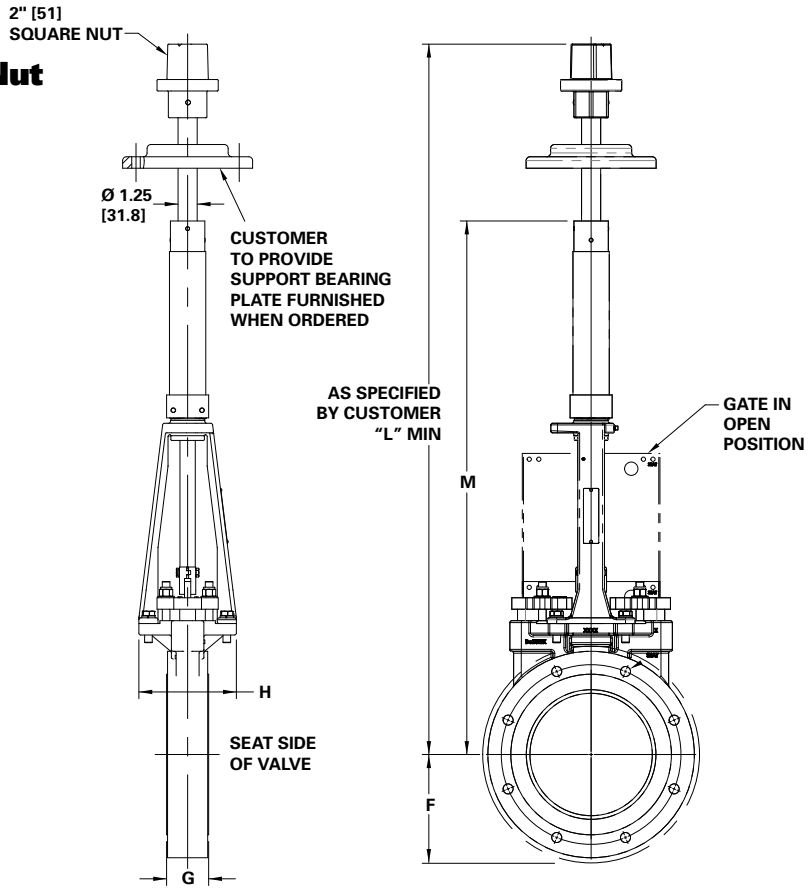

Dimensions

Extended Flange Valve & Extended Nut

Valve Size	Dimensions						
	E	F	G		H	L	M
			EFS	EFL			
2" 50mm	0.75 19	3.25 83	5.88 149	6.88 175	4.00 102	22.44 570	17.63 448
3" 80mm	0.94 24	3.75 95	5.88 149	6.88 175	4.75 121	24.92 633	20.11 511
4" 100mm	0.94 24	4.50 114	5.88 149	6.88 175	5.00 127	28.20 716	23.39 594
5" 125mm	0.94 24	5.00 127	6.00 152	7.00 178	5.75 146	32.62 829	27.81 706
6" 150mm	1.00 25	5.50 140	6.00 152	7.00 178	5.75 146	34.20 869	29.39 747
8" 200mm	1.12 28	6.75 171	6.25 159	7.25 184	6.38 162	39.70 1008	34.89 886
10" 250mm	1.19 30	8.00 203	N/A	8.88 226	8.25 210	46.53 1182	41.72 1060
12" 300mm	1.25 32	9.50 241	N/A	10.13 257	8.25 210	52.19 1326	47.38 1203
14" 350mm	1.38 35	10.50 267	N/A	10.13 257	8.25 210	63.19 1605	58.38 1483
16" 400mm	1.44 37	11.75 298	N/A	11.00 279	8.69 221	70.63 1794	65.82 1672

Inches
Millimeters

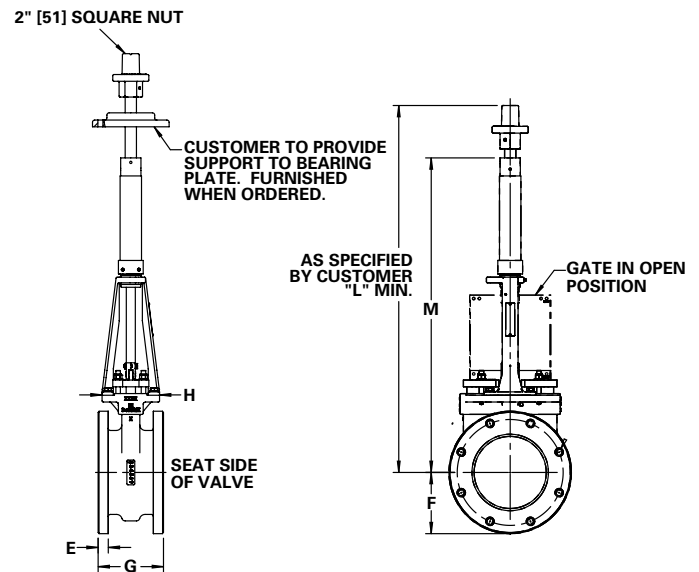

Dimensions

Standard Flanged Valve and Handwheel

Valve Size	Dimensions					
	F	G	H	K	L	M
2" 50mm	3.25 83	1.88 48	4.00 102	14.93 379	13.25 337	8.00 203
2.5" 65mm	3.64 92	2.00 51	4.75 121	16.44 418	14.42 366	8.00 203
3" 80mm	3.75 95	2.00 51	4.75 121	16.62 422	14.74 374	8.00 203
4" 100mm	4.50 114	2.00 51	5.00 127	19.94 506	17.27 439	12.00 305
5" 125mm	5.00 127	2.25 57	5.75 146	24.35 618	19.71 501	12.00 305
	5.00 127	2.25 57	5.75 146	24.35 618	19.58 497	16.00 406
6" 150mm	5.50 140	2.25 57	5.75 146	26.04 661	21.22 539	12.00 305
	5.50 140	2.25 57	5.75 146	26.04 661	21.14 537	16.00 406
8" 200mm	6.75 171	2.75 70	6.38 162	31.54 801	24.63 626	16.00 406
10" 250mm	8.00 203	2.75 70	8.25 210	39.05 992	30.10 765	16.00 406
12" 300mm	9.50 241	3.00 76	8.25 210	44.75 1137	33.79 858	16.00 406
14" 350mm	10.50 267	3.00 76	8.30 211	53.66 1363	36.53 928	20.00 508
16" 400mm	11.75 298	3.50 8	8.70 221	57.23 1454	40.23 1022	20.00 508

Inches
Millimeters

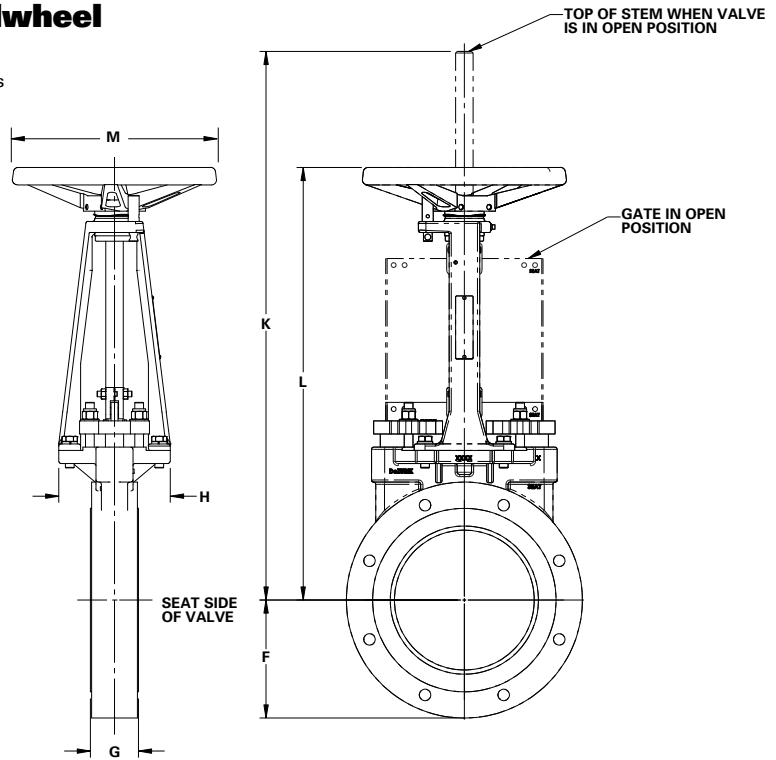

Grooved End Valve and Handwheel

Valve Size	Dimensions					
	F	G	H	K	L	M
2" 50mm	2.19 56	3.21 82	4.00 102	14.85 377	13.30 338	8.00 203
3" 80mm	3.00 76	3.77 96	4.75 121	16.76 426	14.74 374	8.00 203
4" 100mm	3.19 81	4.63 118	5.00 127	20.04 509	17.27 439	12.00 305
5" 125mm	3.66 93	5.88 149	5.75 146	24.48 622	19.71 501	12.00 305
	3.66 93	5.88 149	5.75 146	24.48 622	19.58 497	16.00 406
6" 150mm	4.38 111	5.88 149	5.75 146	26.04 661	21.22 539	12.00 305
	4.38 111	5.88 149	5.75 146	26.04 661	21.14 537	16.00 406
8" 200mm	5.13 130	5.33 135	6.38 162	31.54 801	24.63 626	16.00 406
10" 250mm	6.54 166	6.40 163	8.25 210	39.25 997	30.10 765	16.00 406
12" 300mm	7.38 187	6.50 165	8.25 210	44.93 1141	33.79 858	16.00 406

Inches
Millimeters

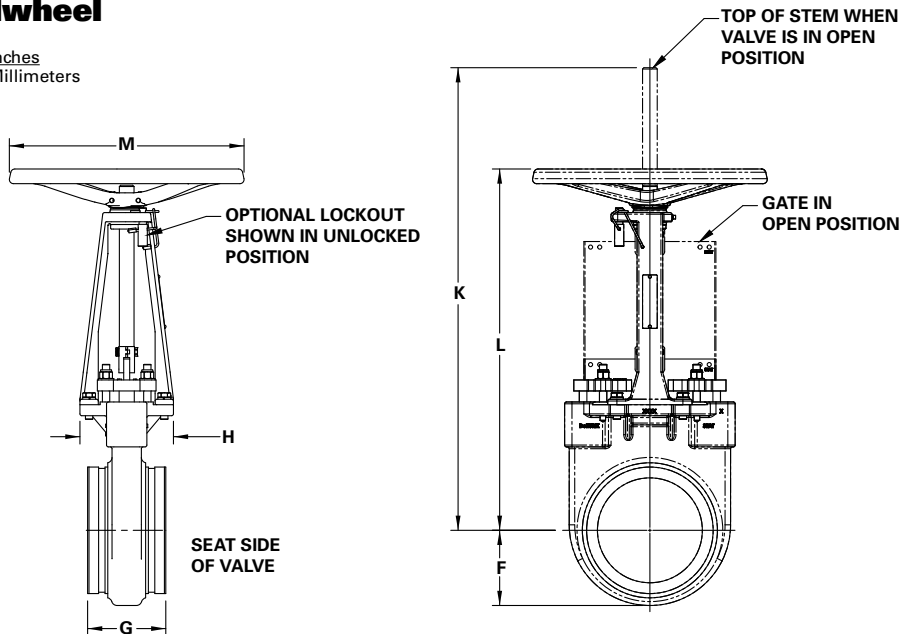

Dimensions

Extended Flanged Valve & Handwheel

Valve Size	Dimensions							
	E	F	G		H	L	M	N
			EFS	EFL				
2" 50mm	0.75 19	3.25 83	5.88 149	6.88 175	4.00 102	14.93 379	13.25 337	8.00 203
3" 80mm	0.94 24	3.75 95	5.88 149	6.88 175	4.75 121	16.62 422	14.74 374	8.00 203
4" 100mm	0.94 24	4.50 114	5.88 149	6.88 175	5.00 127	19.94 506	17.27 439	12.00 305
5" 125mm	0.94 24	5.00 127	6.00 152	7.00 178	5.75 146	24.35 618	19.71 501	12.00 305
	0.94 24	5.00 127	6.00 152	7.00 178	5.75 146	24.35 618	19.58 497	16.00 406
6" 150mm	1.00 25	5.50 140	6.00 152	7.00 178	5.75 146	26.04 661	21.22 539	12.00 305
	1.00 25	5.50 140	6.00 152	7.00 178	5.75 146	26.04 661	21.14 537	16.00 406
8" 200mm	1.12 28	6.75 171	6.25 159	7.25 184	6.38 162	31.54 801	24.63 626	16.00 406
10" 250mm	1.19 30	8.00 203	N/A	8.88 226	8.25 210	39.05 992	30.10 765	16.00 406
12" 300mm	1.25 32	9.50 241	N/A	10.13 257	8.25 210	44.75 1137	33.79 858	16.00 406

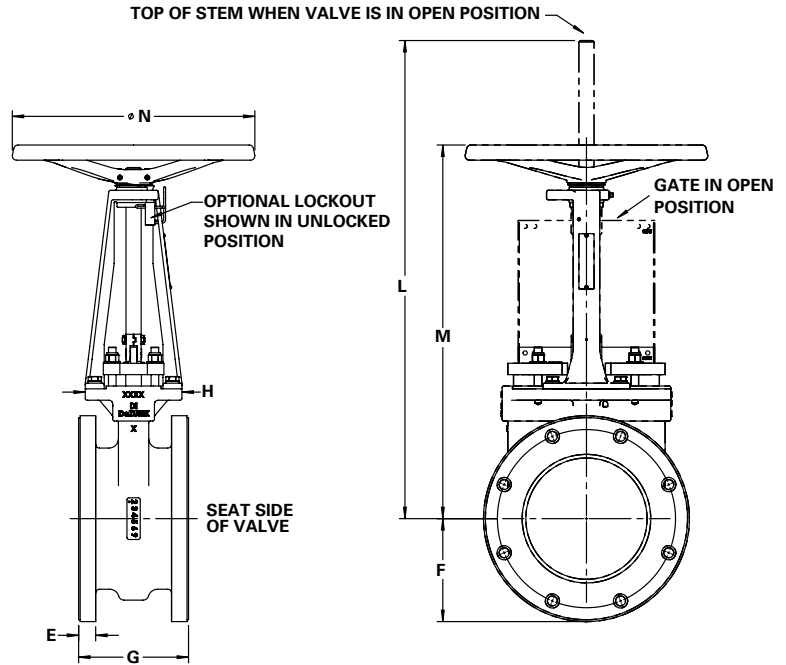

Dimensions

Extended Flanged Valve & Chainwheel

Valve Size	Dimensions							
	E	F	G		H	L	M	N
			EFS	EFL				
2" 50mm	0.75 19	3.25 83	5.88 149	6.88 175	4.00 102	15.94 405	13.83 351	8.00 203
3" 80mm	0.94 24	3.75 95	5.88 149	6.88 175	4.75 121	18.63 473	15.49 393	8.00 203
4" 100mm	0.94 24	4.50 114	5.88 149	6.88 175	5.00 127	21.74 552	17.60 447	12.00 305
5" 125mm	0.94 24	5.00 127	6.00 152	7.00 178	5.75 146	25.17 639	20.03 509	12.00 305
	0.94 24	5.00 127	6.00 152	7.00 178	5.75 146	25.17 639	20.03 509	20.00 508
6" 150mm	1.00 25	5.50 140	6.00 152	7.00 178	5.75 146	27.74 705	21.58 548	20.00 508
	1.12 28	6.75 171	6.25 159	7.25 184	6.38 162	33.31 846	25.07 637	20.00 508
10" 250mm	1.19 30	8.00 203	N/A	8.88 226	8.25 210	40.86 1038	30.57 776	20.00 508
12" 300mm	1.25 32	9.50 241	N/A	10.13 257	8.25 210	46.94 1192	34.58 878	20.00 508

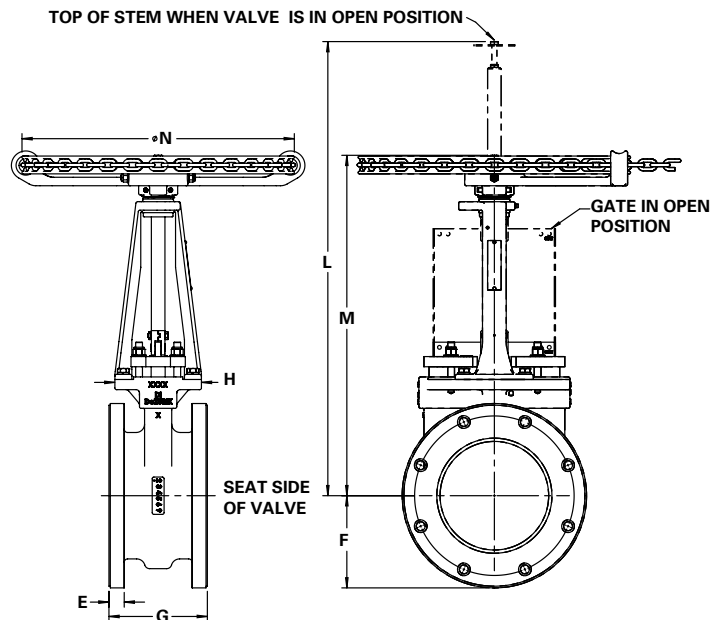

Dimensions

Standard Flanged Valve and Chainwheel

Valve Size	Dimensions					
	F	G	H	K	L	M
2" 50mm	3.25 83	1.88 48	4.00 102	15.94 405	13.83 351	8.00 203
2.5" 65mm	3.64 92	2.00 51	4.75 121	18.44 468	15.72 399	8.00 203
3" 80mm	3.75 95	2.00 51	4.75 121	18.63 473	15.49 393	8.00 203
4" 100mm	4.50 114	2.00 51	5.00 127	21.74 552	17.60 447	12.00 305
5" 125mm	5.00 127	2.25 57	5.75 146	25.17 639	20.03 509	12.00 305
	5.00 127	2.25 57	5.75 146	25.17 639	20.03 509	20.00 508
6" 150mm	5.50 140	2.25 57	5.75 146	27.74 705	21.58 548	20.00 508
	6.75 171	2.75 70	6.38 162	33.31 846	25.07 637	20.00 508
10" 250mm	8.00 203	2.75 70	8.25 210	40.86 1038	30.57 776	20.00 508
	9.50 241	3.00 76	8.25 210	46.94 1192	34.58 878	20.00 508
14" 350mm	10.50 267	3.00 76	8.25 210	53.56 1360	41.09 1044	30.00 762
	11.75 298	3.50 89	8.69 221	57.23 1454	42.69 1084	30.00 762

Inches
Millimeters

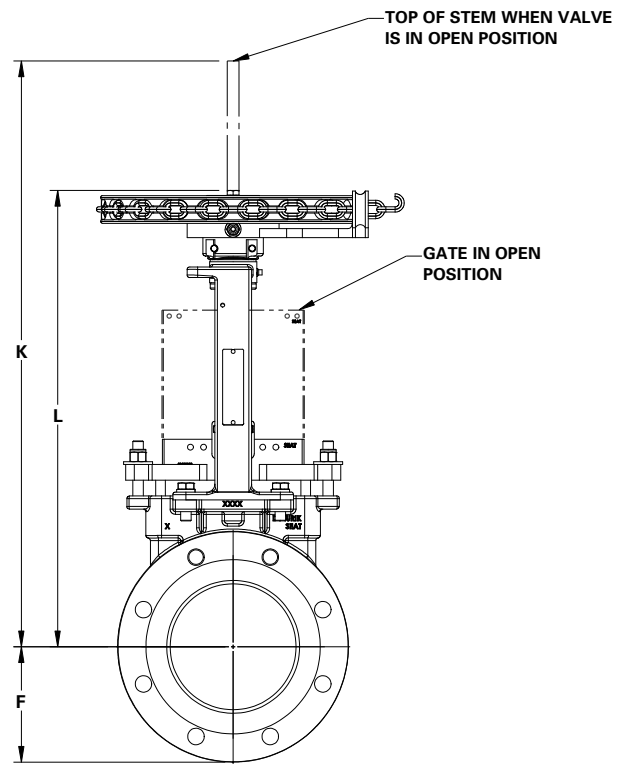
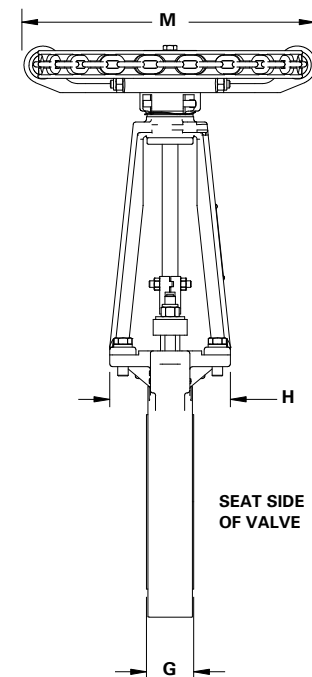

Grooved End Valve and Chainwheel

Valve Size	Dimensions					
	F	G	H	K	L	M
2" 50mm	2.19 56	3.21 82	4.00 102	16.33 415	13.95 354	8.00 203
3" 80mm	3.00 76	3.77 96	4.75 121	18.76 477	15.63 397	8.00 203
4" 100mm	3.19 81	4.63 118	5.00 127	21.98 558	17.89 454	12.00 305
5" 125mm	3.66 93	5.88 149	5.75 146	25.68 652	20.58 523	12.00 305
	3.66 93	5.88 149	5.75 146	25.68 652	20.58 523	20.00 508
6" 150mm	4.38 111	5.88 149	5.75 146	27.92 709	21.72 552	20.00 508
	5.13 130	5.33 135	6.38 162	33.45 850	25.44 646	20.00 508
10" 250mm	6.54 166	6.40 163	8.25 210	41.06 1043	30.93 786	20.00 508
	7.38 187	6.50 165	8.25 210	47.13 1197	34.97 888	20.00 508

Inches
Millimeters

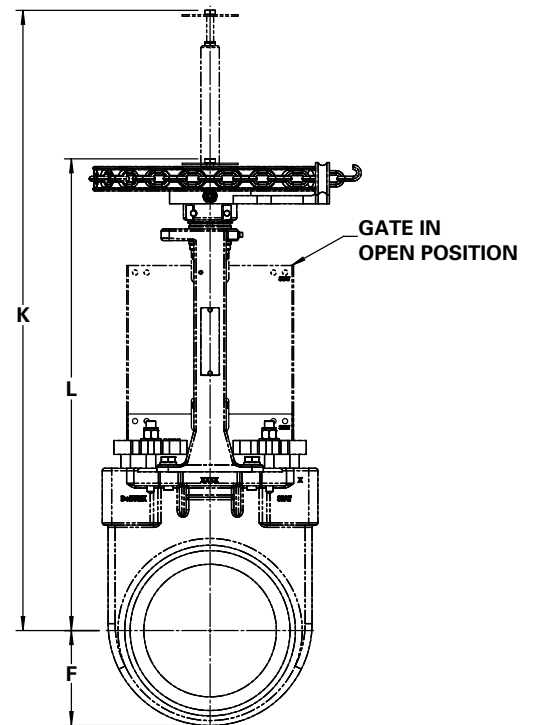
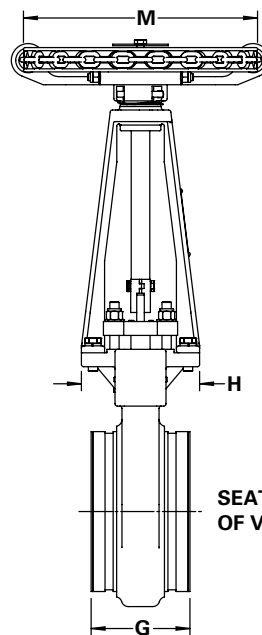

Dimensions

Standard Flanged Valve and Bevel Gear Handwheel 3-8" MU & HP Body Styles

Valve Size	Dimensions						
	F	G	H	L	M	N	P
3" 80mm	3.75 95	2.00 51	4.75 121	22.12 562	16.19 411	12.00 305	10.12 257
4" 100mm	4.50 114	2.00 51	5.00 127	24.38 619	18.47 469	12.00 305	10.12 257
5" 125mm	5.80 147	2.25 57	5.75 146	28.82 732	20.91 531	12.00 305	10.12 257
6" 150mm	5.48 139	2.25 57	5.75 146	30.39 772	22.47 571	12.00 305	10.12 257
8" 200mm	6.75 171	2.75 70	6.38 162	35.89 912	25.97 660	12.00 305	10.12 257

Inches
Millimeters

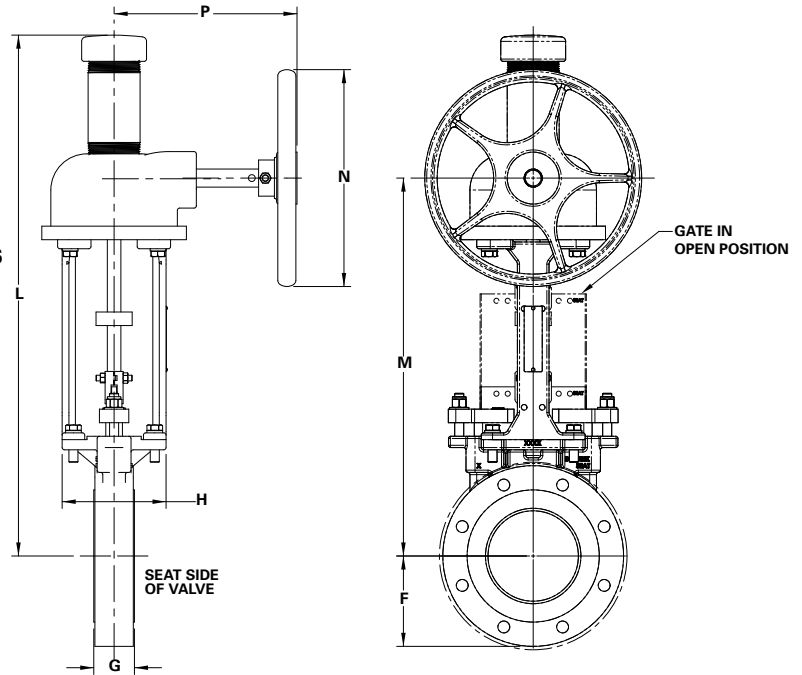

10" & Larger MU & HP Body Styles

Valve Size	Dimensions				
	F	G	H	L	M
10" 250mm	8.00 203	2.75 70	8.24 209	46.57 1183	31.66 804
12" 300mm	9.50 241	3.00 76	8.25 210	50.26 1277	35.35 898
14" 350mm	10.50 267	3.00 76	8.25 210	56.82 1443	37.91 963
16" 400mm	11.75 298	3.50 89	8.69 221	60.51 1537	41.60 1057
18" 450mm	12.50 318	3.50 89	9.31 236	69.95 1777	47.04 1195
20" 500mm	13.75 349	4.50 114	9.42 239	73.63 1870	50.72 1288
24" 600mm	16.00 406	4.50 114	9.42 239	81.20 2062	61.58 1564
30" 750mm	19.38 492	5.50 140	11.25 286	109.58 2783	76.00 1930
36" 900mm	23.00 584	6.00 152	12.00 305	121.46 3085	87.49 2222
42" 1050mm	26.50 673	6.50 165	13.50 343	150.30 3818	103.51 2629
48" 1200mm	29.75 756	7.00 178	18.50 470	163.64 4156	116.85 2968

Standard Flanged Valve 10" & Larger, MU Body Style

Valve Size	MU Body Style		
	N	P	
		Standard & 180 Mounting	90 & 270 Mounting
10" 250mm	12.00 305	10.12 257	10.12 257
12" 300mm	12.00 305	10.12 257	10.12 257
14" 350mm	12.00 305	10.12 257	24.13 613
16" 400mm	16.00 406	17.62 448	24.13 613
18" 450mm	24.00 610	17.62 448	32.88 835
20" 500mm	24.00 610	17.62 448	32.88 835
24" 600mm	24.00 610	23.75 603	33.75 857
30" 750mm	24.00 610	23.75 603	33.75 857
36" 900mm	24.00 610	23.75 603	32.87 835
42" 1050mm	24.00 610	25.55 649	36.57 929
48" 1200mm	24.00 610	25.55 649	36.57 929

Standard Flanged Valve 10" & Larger, HP Body Style

Valve Size	HP Body Style		
	N	P	
		Standard & 180 Mounting	90 & 270 Mounting
10" 250mm	16.00 406	10.50 267	10.50 267
12" 300mm	16.00 406	10.50 267	10.50 267
14" 350mm	16.00 406	10.50 267	24.15 613
16" 400mm	24.00 610	17.62 448	32.88 835
18" 450mm	30.00 762	9.75 248	24.13 613
20" 500mm	36.00 914	23.15 588	38.40 975
24" 600mm	24.00 610	23.75 603	33.75 857
30" 750mm	24.00 610	26.57 675	36.57 929
36" 900mm	24.00 610	26.57 675	36.57 929
42" 1050mm	30.00 762	17.68 449	28.72 729
48" 1200mm	30.00 762	17.68 449	28.72 729

Dimensions

Extended Flanged Valve & Bevel Gear Handwheel 3-12" Valve Sizes

Valve Size	Dimensions								
	E	F	G		H	L	M	N	P
			EFS	EFL					
3" 80mm	0.94 24	3.75 95	5.88 149	6.88 175	4.75 121	22.12 562	16.19 411	12.00 305	10.12 257
4" 100mm	0.94 24	4.50 114	5.88 149	6.88 175	5.00 127	24.38 619	18.47 469	12.00 305	10.12 257
5" 125mm	0.94 24	5.00 127	6.00 152	7.00 178	5.75 146	28.82 732	20.91 531	12.00 305	10.12 257
6" 150mm	1.00 25	5.50 140	6.00 152	7.00 178	5.75 146	30.39 772	22.47 571	12.00 305	10.12 257
8" 200mm	1.12 28	6.75 171	6.25 159	7.25 184	6.38 162	35.89 912	25.97 660	12.00 305	10.12 257
10" 250mm	1.19 30	8.00 203	N/A	8.88 226	8.25 210	46.57 1183	31.66 804	12.00 305	10.12 257
	1.19 30	8.00 203	N/A	8.88 226	8.25 210	46.57 1183	31.66 804	16.00 406	10.50 267
12" 300mm	1.25 32	9.50 241	N/A	10.13 257	8.25 210	50.26 1277	35.35 898	12.00 305	10.12 257
	1.25 32	9.50 241	N/A	10.13 257	8.25 210	50.26 1277	35.35 898	16.00 406	10.50 267

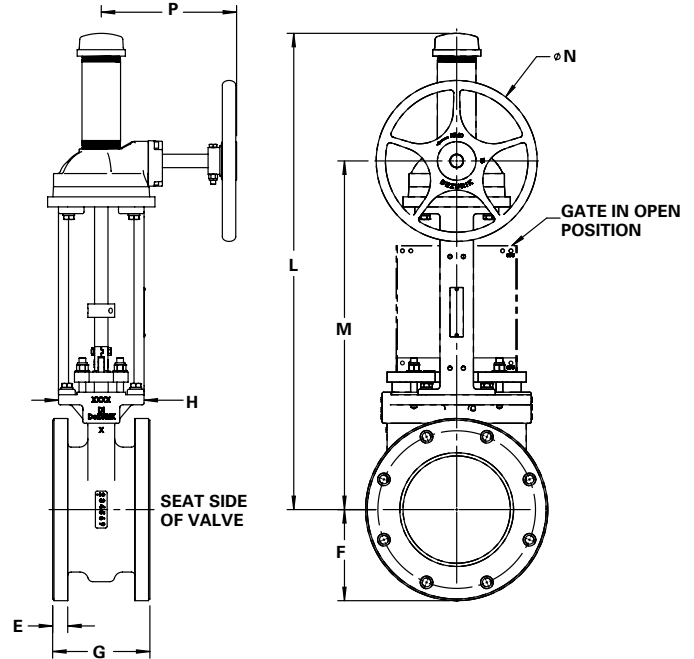

14" & Larger MU & HP Body Styles

Valve Size	Dimensions			
	E	F	G EFL	H
14" 350mm	1.38 35	10.50 267	10.13 257	8.25 210
16" 400mm	1.44 37	11.75 298	11.00 279	8.69 221
18" 450mm	1.56 40	12.50 318	12.25 311	9.31 236
20" 500mm	1.69 43	13.75 349	14.13 359	9.42 239
24" 600mm	1.87 47	16.00 406	14.63 372	9.42 239
30" 750mm	2.94 75	19.38 492	15.57 395	11.25 286
36" 900mm	3.56 90	23.00 584	18.50 470	12.00 305
42" 1050mm	3.81 97	26.50 673	21.13 537	13.50 343
48" 1200mm	4.25 108	29.75 756	21.13 537	18.50 470

MU Body Styles

Valve Size	Dimensions				
	L	M	N	Std & 180 Mounting	90 & 270 Mounting
14" 350mm	56.82 1443	37.91 963	12.00 305	10.12 257	24.59 625
16" 400mm	60.51 1537	41.60 1057	16.00 406	10.50 267	24.09 612
18" 450mm	69.95 1777	47.04 1195	24.00 610	24.18 614	24.09 612
20" 500mm	73.63 1870	50.72 1288	24.00 610	24.16 614	32.40 823
24" 600mm	83.60 2123	61.58 1564	24.00 610	24.18 614	32.40 823
30" 750mm	109.58 2783	76.00 1930	24.00 610	24.18 614	33.31 846
36" 900mm	121.46 3085	87.49 2222	24.00 610	24.18 614	33.31 846
42" 1050mm	150.30 3818	103.51 2629	24.00 610	27.01 686	36.14 918
48" 1200mm	163.64 4156	116.85 2968	24.00 610	27.01 686	36.14 918

HP Body Style

Valve Size	Dimensions				
	L	M	N	Std & 180 Mounting	90 & 270 Mounting
14" 350mm	56.82 1443	37.91 963	16.00 406	10.50 267	24.09 612
16" 400mm	60.51 1537	41.60 1057	24.00 610	24.18 614	32.40 823
18" 450mm	69.95 1777	47.04 1195	30.00 762	10.46 266	24.09 612
20" 500mm	73.63 1870	50.72 1288	36.00 914	23.87 606	37.50 953
24" 600mm	83.60 2123	61.58 1564	24.00 610	24.18 614	33.31 846
30" 750mm	111.95 2844	77.16 1960	24.00 610	27.01 686	36.14 918
36" 900mm	123.45 3136	88.66 2252	24.00 610	27.01 686	36.14 918
42" 1050mm	150.30 3818	103.51 2629	30.00 762	18.70 475	27.82 707
48" 1200mm	163.64 4156	116.85 2968	30.00 762	18.70 475	27.82 707

Dimensions

Standard Flanged Valve and Bevel Gear Chainwheel 3-8" MU & HP Body Styles

Valve Size	Dimensions							
	F	G	H	L	M	N	P	
							Standard & 180 Mounting	90 & 270 Mounting
3" 80mm	3.75 95	2.00 51	4.75 121	22.12 562	16.19 411	12.75 324	9.62 244	9.62 244
4" 100mm	4.50 114	2.00 51	5.00 127	24.39 620	18.47 469	12.75 324	9.62 244	9.62 244
5" 125mm	5.80 147	2.25 57	5.75 146	28.83 732	20.89 531	12.75 324	9.62 244	9.62 244
6" 150mm	5.48 139	2.25 57	5.75 146	30.41 772	22.47 571	12.75 324	9.62 244	9.62 244
8" 200mm	6.75 171	2.75 70	6.38 162	34.90 886	25.97 660	12.75 324	9.62 244	9.62 244

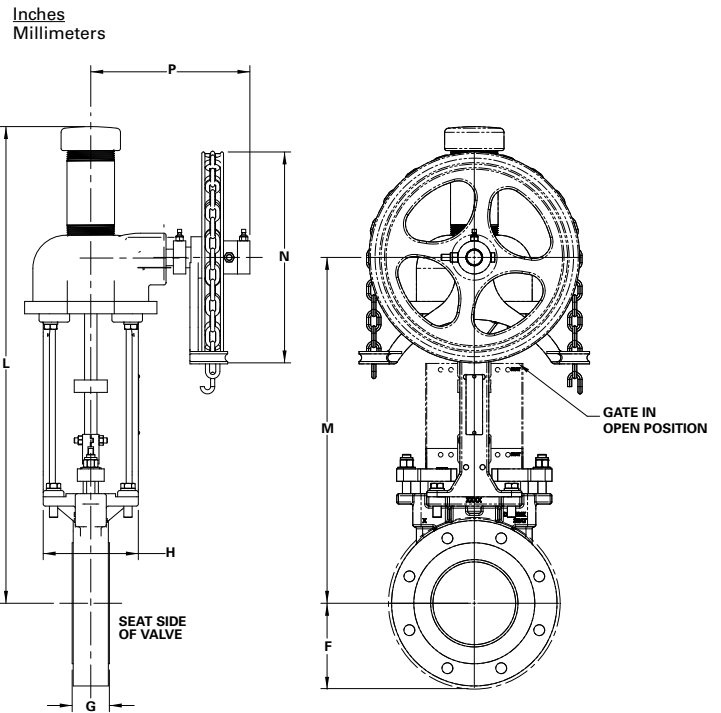

Flanged Valve 10" & Larger, MU Body Style

Valve Size	Dimensions							
	F	G	H	L	M	N	P	
							Standard & 180 Mounting	90 & 270 Mounting
10" 250mm	8.00 203	2.75 70	8.24 209	46.57 1183	31.66 804	12.00 305	9.62 244	9.62 244
12" 300mm	9.50 241	3.00 76	8.25 210	50.26 1277	35.35 898	12.00 305	9.62 244	9.62 244
14" 350mm	10.50 267	3.00 76	8.25 210	56.82 1443	37.91 963	12.75 324	9.62 244	24.12 613
16" 400mm	11.75 298	3.50 89	8.69 221	60.51 1537	41.60 1057	20.00 508	9.62 244	24.12 613
18" 450mm	12.50 318	3.50 89	9.31 236	69.95 1777	47.04 1195	30.00 762	9.62 244	24.12 613
20" 500mm	13.75 349	4.50 114	9.42 239	73.63 1870	50.72 1288	30.00 762	9.62 244	24.12 613
24" 600mm	16.19 411	4.50 114	9.42 239	81.20 2062	61.58 1564	20.00 508	15.00 381	25.00 635
30" 750mm	19.38 492	5.50 140	11.25 286	109.58 2783	76.00 1930	20.00 508	15.00 381	25.00 635
36" 900mm	23.00 584	6.00 152	12.00 305	121.46 3085	87.49 2222	30.00 762	15.00 381	25.00 635
42" 1050mm	26.50 673	6.50 165	13.50 343	150.30 3818	103.51 2629	30.00 762	17.82 453	27.82 707
48" 1200mm	29.75 756	7.00 178	18.50 470	163.64 4156	116.85 2968	30.00 762	17.82 453	27.82 707

Flanged Valve 10" & Larger, HP Body Style

Valve Size	Dimensions							
	F	G	H	L	M	N	P	
							Standard & 180 Mounting	90 & 270 Mounting
10" 250mm	8.00 203	2.75 70	8.24 209	46.57 1183	31.66 804	20.00 508	9.62 244	9.62 244
12" 300mm	9.50 241	3.00 76	8.25 210	50.26 1277	35.35 898	20.00 508	9.62 244	9.62 244
14" 350mm	10.50 267	3.00 76	8.25 210	56.82 1443	37.91 963	20.00 508	9.62 244	24.12 613
16" 400mm	11.75 298	3.50 89	8.69 221	60.51 1537	41.60 1057	30.00 762	9.62 244	24.12 613
18" 450mm	12.50 318	3.50 89	9.31 236	69.95 1777	47.04 1195	30.00 762	9.62 244	24.12 613
20" 500mm	13.75 349	4.50 114	9.42 239	73.63 1870	53.61 1362	30.00 762	15.00 381	25.00 635
24" 600mm	16.19 411	4.50 114	9.42 239	81.20 2062	61.58 1564	30.00 762	15.00 381	25.00 635
30" 750mm	19.38 492	5.50 140	11.25 286	111.95 2844	77.16 1960	30.00 762	17.82 453	25.00 635
36" 900mm	23.00 584	6.00 152	12.00 305	123.45 3136	88.65 2252	30.00 762	17.82 453	27.82 707
42" 1050mm	26.50 673	6.50 165	13.50 343	150.30 3818	103.51 2629	30.00 762	17.82 453	27.82 707
48" 1200mm	29.75 756	7.00 178	18.50 470	163.64 4156	116.85 2968	30.00 762	17.82 453	27.82 707

Dimensions

Extended Flanged Valve & Bevel Gear Chainwheel 3-12" Valve Sizes

Valve Size	Dimensions								
	E	F	G		H	L	M	N	P
			EFS	EFL					
3" 80mm	0.94 24	3.75 95	5.88 149	6.88 175	4.75 121	22.12 562	16.19 411	12.00 305	9.59 244
4" 100mm	0.94 24	4.50 114	5.88 149	6.88 175	5.00 127	24.38 619	18.47 469	12.00 305	9.59 244
5" 125mm	0.94 24	5.00 127	6.00 152	7.00 178	5.75 146	28.82 732	20.91 531	12.00 305	9.59 244
6" 150mm	1.00 25	5.50 140	6.00 152	7.00 178	5.75 146	30.39 772	22.47 571	12.00 305	9.59 244
8" 200mm	1.12 28	6.75 171	6.25 159	7.25 184	6.38 162	35.89 912	25.97 660	12.00 305	9.59 244
10" 250mm	1.19 30	8.00 203	N/A	8.88 226	8.25 210	46.57 1183	31.66 804	12.00 305	9.59 244
	1.19 30	8.00 203	N/A	8.88 226	8.25 210	46.57 1183	31.66 804	20.00 508	9.59 244
12" 300mm	1.25 32	9.50 241	N/A	10.13 257	8.25 210	50.26 1277	35.35 898	12.00 305	9.59 244
	1.25 32	9.50 241	N/A	10.13 257	8.25 210	50.26 1277	35.35 898	20.00 508	9.59 244

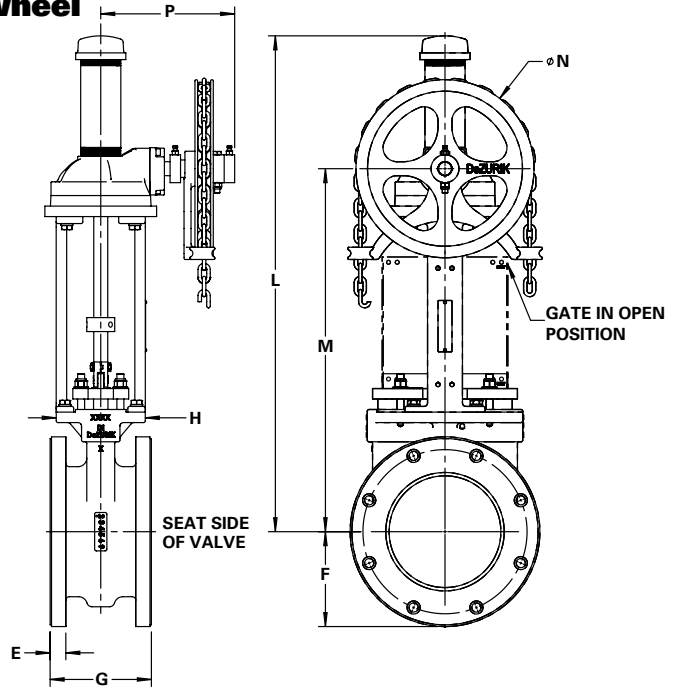

14" & Larger

MU & HP Body Styles

Valve Size	Dimensions			
	E	F	G EFL	H
14" 350mm	1.38 35	10.50 267	10.13 257	8.25 210
16" 400mm	1.44 37	11.75 298	11.00 279	8.69 221
18" 450mm	1.56 40	12.50 318	12.25 311	9.31 236
20" 500mm	1.69 43	13.75 349	14.13 359	9.42 239
24" 600mm	1.87 47	16.00 406	14.63 372	9.42 239
30" 750mm	2.94 75	19.38 492	15.57 395	11.25 286
36" 900mm	3.56 90	23.00 584	18.50 470	12.00 305
42" 1050mm	3.81 97	26.50 673	21.13 537	13.50 343
48" 1200mm	4.25 108	29.75 756	21.13 537	18.50 470

MU Body Styles

Valve Size	Dimensions				
	L	M	N	Std & 180 Mounting	90 & 270 Mounting
14" 350mm	56.86 1444	37.91 963	12.00 305	9.59 244	24.09 612
16" 400mm	60.51 1537	41.60 1057	20.00 508	9.59 244	24.09 612
18" 450mm	69.95 1777	47.04 1195	20.00 508	9.59 244	24.09 612
20" 500mm	73.63 1870	50.72 1288	20.00 508	9.59 244	24.09 612
24" 600mm	83.60 2123	61.58 1564	20.00 508	15.00 381	25.00 635
30" 750mm	109.58 2783	76.00 1930	20.00 508	15.00 381	25.00 635
36" 900mm	121.46 3085	87.49 2222	30.00 762	15.00 381	25.00 635
42" 1050mm	150.30 3818	103.51 2629	30.00 762	17.82 453	27.82 707
48" 1200mm	163.64 4156	116.85 2968	30.00 762	17.82 453	27.82 707

HP Body Style

Valve Size	Dimensions				
	L	M	N	Std & 180 Mounting	90 & 270 Mounting
14" 350mm	56.82 1443	37.91 963	20.00 508	9.59 244	24.09 612
16" 400mm	60.51 1537	41.60 1057	30.00 762	9.59 244	24.09 612
18" 450mm	69.95 1777	47.04 1195	30.00 762	9.59 244	24.09 612
20" 500mm	73.63 1870	50.72 1288	30.00 762	9.59 244	24.09 612
24" 600mm	81.20 2062	61.58 1564	30.00 762	15.00 381	25.00 635
30" 750mm	111.95 2844	77.16 1960	30.00 762	17.82 453	27.82 707
36" 900mm	123.45 3136	88.66 2252	30.00 762	17.82 453	27.82 707
42" 1050mm	150.30 3818	103.51 2629	30.00 762	17.82 453	27.82 707
48" 1200mm	163.64 4156	116.85 2968	30.00 762	17.82 453	27.82 707

Dimensions

Grooved End Valved and Bevel Gear Handwheel

Valve Size	Dimensions						
	F	G	H	L	M	N	P
3" 80mm	3.00 76	3.77 96	4.75 121	22.06 560	16.19 411	12.00 305	10.12 257
4" 100mm	3.19 81	4.63 118	5.00 127	24.38 619	18.47 469	12.00 305	10.12 257
5" 125mm	3.66 93	5.88 149	5.75 146	28.82 732	20.91 531	12.00 305	10.12 257
6" 150mm	4.38 111	5.88 149	5.75 146	30.38 772	22.47 571	12.00 305	10.12 257
8" 200mm	5.13 130	5.33 135	6.38 162	35.88 911	25.97 660	12.00 305	10.12 257
10" 250mm	6.54 166	6.40 163	8.25 210	46.57 1183	31.66 804	12.00 305	10.12 257
	6.54 166	6.40 163	8.25 210	46.57 1183	31.66 804	16.00 406	10.50 267
12" 300mm	7.38 187	6.50 165	8.25 210	50.26 1277	35.35 898	12.00 305	10.12 257
	7.38 187	6.50 165	8.25 210	50.26 1277	35.35 898	16.00 406	10.50 267

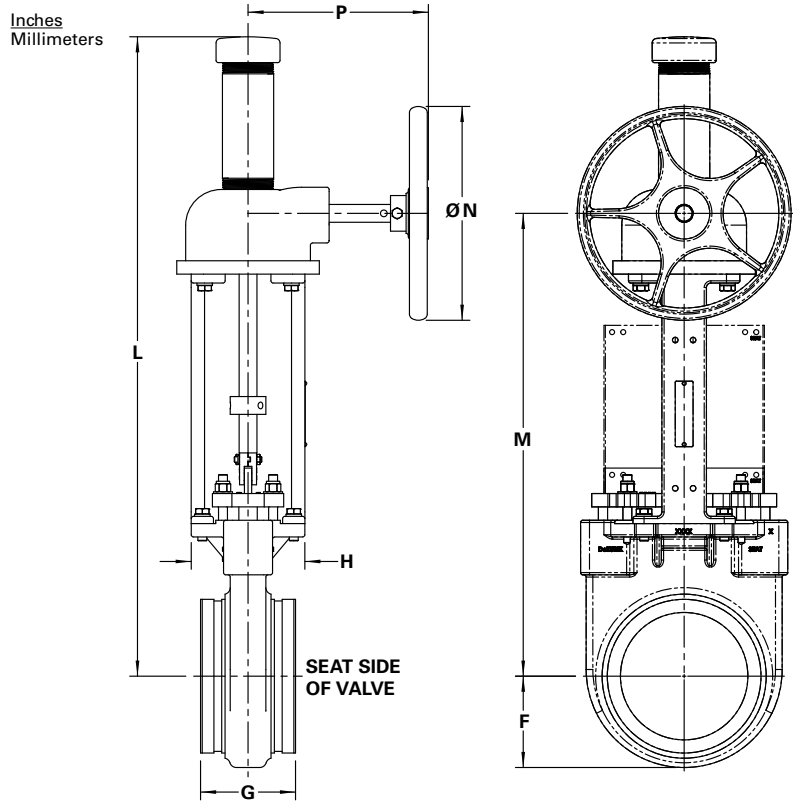

Grooved End Valved and Bevel Gear Chainwheel

Valve Size	Dimensions						
	F	G	H	L	M	N	P
3" 80mm	3.00 76	3.77 96	4.75 121	22.06 560	16.19 411	12.00 305	9.62 244
4" 100mm	3.19 81	4.63 118	5.00 127	24.38 619	18.47 469	12.00 305	9.62 244
5" 125mm	3.66 93	5.88 149	5.75 146	28.82 732	20.91 531	12.00 305	9.62 244
6" 150mm	4.38 111	5.88 149	5.75 146	30.38 772	22.47 571	12.00 305	9.62 244
8" 200mm	5.13 130	5.33 135	6.38 162	35.88 911	25.97 660	12.00 305	9.62 244
10" 250mm	6.54 166	6.40 163	8.25 210	46.57 1183	31.66 804	12.00 305	9.62 244
	6.54 166	6.40 163	8.25 210	46.57 1183	31.66 804	20.00 508	9.62 244
12" 300mm	7.38 187	6.50 165	8.25 210	50.26 1277	35.35 898	12.00 305	9.62 244
	7.38 187	6.50 165	8.25 210	50.26 1277	35.35 898	20.00 508	9.62 244

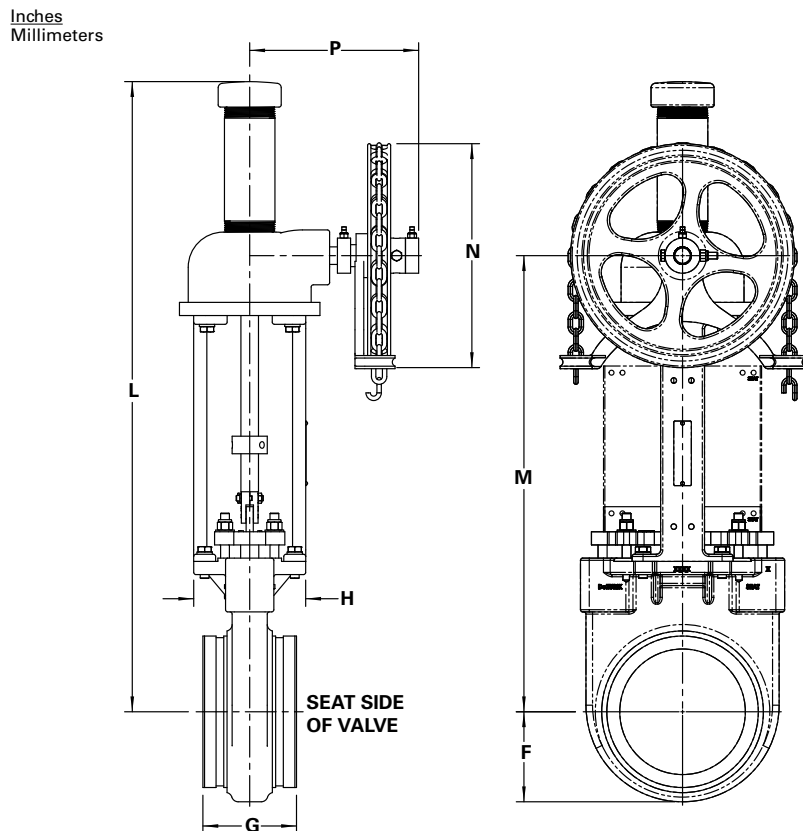

Dimensions

Standard Flanged Valve and Cylinder Actuator

Valve Size	Dimensions		
	F	G	H
2"	3.25	1.88	4.00
50mm	83	48	102
2.5"	3.64	2.00	4.75
65mm	92	51	121
3"	3.75	2.00	4.75
80mm	95	51	121
4"	4.50	2.00	5.00
100mm	114	51	127
5"	5.00	2.25	5.75
125mm	127	57	146
6"	5.50	2.25	5.75
150mm	140	57	146
8"	6.75	2.75	6.38
200mm	171	70	162
10"	8.00	2.75	8.25
250mm	203	70	210
12"	9.50	3.00	8.25
300mm	241	76	210
14"	10.50	3.00	8.25
350mm	267	76	210
16"	11.75	3.50	8.69
400mm	298	89	221
18"	12.50	3.50	9.31
450mm	318	89	237
20"	13.75	4.50	9.42
500mm	349	114	239
24"	16.00	4.50	9.42
600mm	406	114	239

Inches
Millimeters

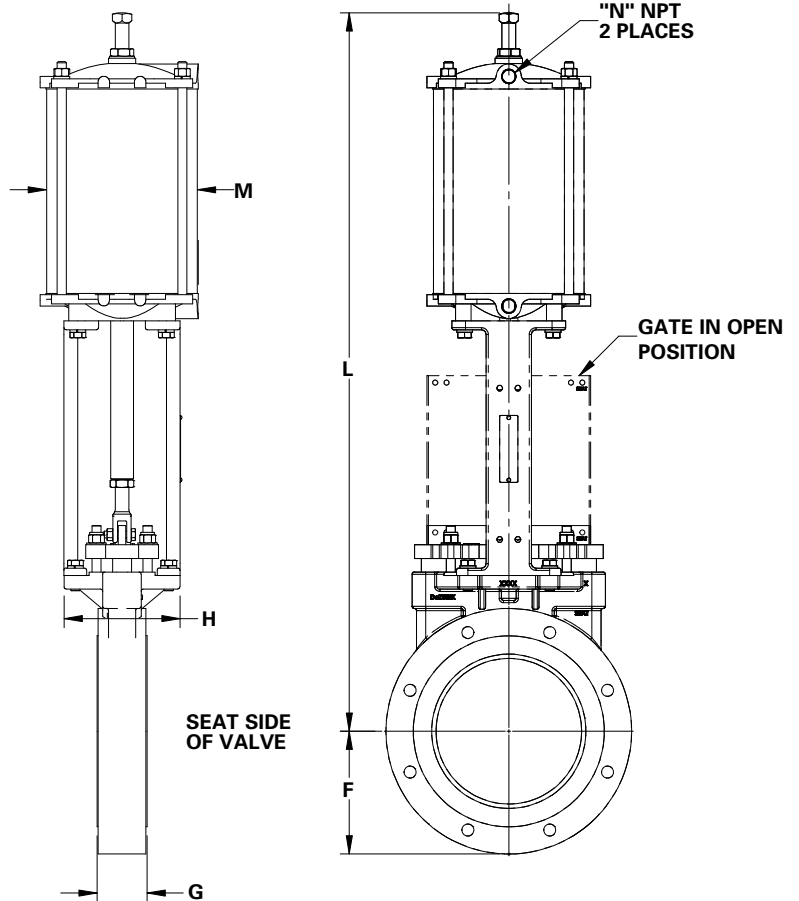

Cylinder Actuator

Actuator Code	Dimensions														M	N
	L															
	2" 50mm	2.5" 65mm	3" 80mm	4" 100mm	5" 125mm	6" 150mm	8" 200mm	10" 250mm	12" 300mm	14" 350mm	16" 400mm	18" 450mm	20" 500mm	24" 600mm		
CY-PC4	22.18 563	23.53 598	23.84 606	26.12 663	30.47 774	32.09 815	—	—	—	—	—	—	—	—	5.38 137	1/4
CY-PC6	—	—	—	29.45 748	32.13 816	33.48 850	39.25 997	—	—	—	—	—	—	—	7.88 200	1/4
CY-PC8	—	—	—	—	32.50 826	34.13 867	39.63 1007	49.16 1249	53.18 1351	—	—	—	—	—	10.50* 267	1/2
CY-PC10	—	—	—	—	—	—	—	50.66 1287	54.35 1380	60.56 1538	64.25 1632	—	—	—	10.88 276	1/2
CY-PC12	—	—	—	—	—	—	—	50.74 1289	54.55 1386	60.68 1541	64.37 1635	73.81 1875	77.50 1969	89.46 2272	12.94 329	1/2
CY-PC14	—	—	—	—	—	—	—	—	—	—	64.31 1633	74.15 1883	77.84 1977	89.81 2281	15.13 384	1/2
CY-PC16	—	—	—	—	—	—	—	—	—	—	—	70.25 1784	75.94 1929	87.91 2233	17.00 432	1/2
CY-PC18	—	—	—	—	—	—	—	—	—	—	—	—	—	88.28 2242	19.00 483	3/4

Inches
Millimeters

* M Dimension on 10" & 12" valve sizes is 8.69
271

Dimensions

Extended Flanged Valve & Pneumatic Cylinder Actuator

Valve Size	Dimensions					
	E	F	G		H	P
			EFS	EFL		
2" 50mm	0.75 19	3.25 83	5.88 149	6.88 175	4.00 102	10.80 274
3" 80mm	0.94 24	3.75 95	5.88 149	6.88 175	4.75 121	12.28 312
4" 100mm	0.94 24	4.50 114	5.88 149	6.88 175	5.00 127	14.56 370
5" 125mm	0.94 24	5.00 127	6.00 152	7.00 178	5.75 146	16.94 430
6" 150mm	1.00 25	5.50 140	6.00 152	7.00 178	5.75 146	18.56 471
8" 200mm	1.12 28	6.75 171	6.25 159	7.25 184	6.38 162	22.06 560
10" 250mm	1.19 30	8.00 203	N/A	8.88 226	8.25 210	27.63 702
12" 300mm	1.25 32	9.50 241	N/A	10.13 257	8.25 210	31.13 791
14" 350mm	1.38 35	10.50 267	N/A	10.13 257	8.25 210	33.88 861
16" 400mm	1.44 37	11.75 298	N/A	11.00 279	8.69 221	37.56 954
18" 450mm	1.56 40	12.50 318	N/A	12.25 311	9.13 232	42.94 1091
20" 500mm	1.69 43	13.75 349	N/A	14.13 359	9.19 233	46.63 1184
24" 600mm	1.87 47	16.00 406	N/A	14.63 372	9.19 233	54.59 1387

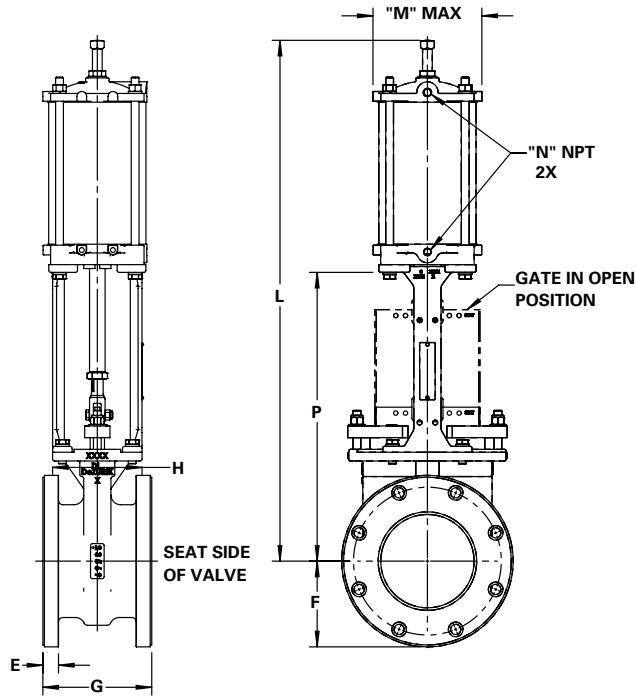

Pneumatic Cylinder Actuator

2-12" Valve Sizes

Actuator Code	Dimensions									M	N
	L										
	2" 50mm	3" 80mm	4" 100mm	5" 125mm	6" 150mm	8" 200mm	10" 250mm	12" 300mm			
CY-PC4	22.18 563	23.84 606	26.12 663	30.47 774	32.09 815	—	—	—	5.38 137	1/4	
CY-PC6	—	—	29.45 748	32.13 816	33.48 850	39.25 997	—	—	7.88 200	1/4	
CY-PC8	—	—	—	32.50 826	34.13 867	39.63 1007	49.16 1249	53.18 1351	8.69 221	1/2	
CY-PC10	—	—	—	—	—	45.18 1148	50.66 1287	54.35 1380	10.88 276	1/2	
CY-PC12	—	—	—	—	—	—	50.74 1289	54.55 1386	12.94 329	1/2	

Inches
Millimeters

14-24" Valve Sizes

Actuator Code	Dimensions						M	N
	L							
	14" 350mm	16" 400mm	18" 450mm	20" 500mm	24" 600mm			
CY-PC10	60.56 1538	64.25 1632	—	—	—	10.88 276	1/2	
CY-PC12	60.68 1541	64.37 1635	73.81 1875	77.50 1969	89.46 2272	12.94 329	1/2	
CY-PC14	—	64.31 1633	74.15 1883	77.84 1977	89.81 2281	15.13 329	1/2	
CY-PC16	—	—	70.25 1784	75.94 1929	87.91 2233	17.00 432	1/2	
CY-PC18	—	—	—	—	88.28 2242	19.00 483	3/4	

Inches
Millimeters

Dimensions

Grooved End Valve and Cylinder Actuator

Valve Size	Dimensions		
	F	G	H
2"	2.19	3.21	4.00
50mm	56	82	102
3"	3.00	3.77	4.75
80mm	76	96	121
4"	3.19	4.63	5.00
100mm	81	118	127
5"	3.66	5.88	5.75
125mm	93	149	146
6"	4.38	5.88	5.75
150mm	111	149	146
8"	5.13	5.33	6.38
200mm	130	135	162
10"	6.54	6.40	8.25
250mm	166	163	210
12"	7.38	6.50	8.25
300mm	187	165	210

Inches
Millimeters

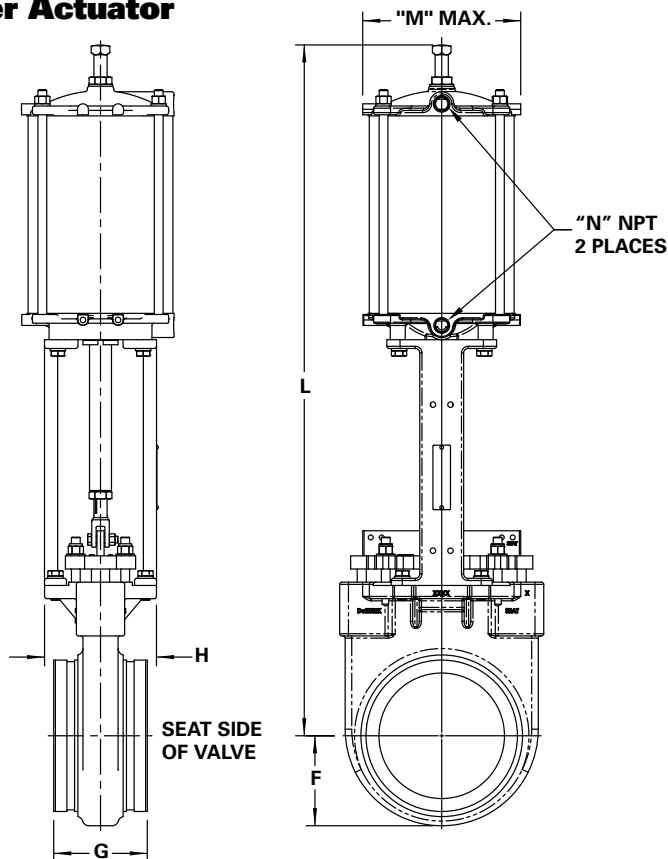

Cylinder Actuator

Actuator Code	Dimensions									
	L								M	N
	2"	3"	4"	5"	6"	8"	10"	12"		
50mm	80mm	100mm	125mm	150mm	200mm	250mm	300mm			
CY-PC4	22.57 573	24.00 610	26.29 668	30.72 780	32.28 820	—	—	—	5.00 127	1/4
CY-PC6	—	—	27.55 700	31.99 813	33.62 854	39.01 991	—	—	7.00 178	1/4
CY-PC8	—	—	—	32.23 819	33.85 860	39.35 999	49.23 1250	52.92 1344	9.00 229	1/2
CY-PC10	—	—	—	—	—	40.86 1038	50.67 1287	54.35 1380	11.25 286	1/2
CY-PC12	—	—	—	—	—	—	50.88 1292	54.56 1386	13.25 337	1/2

Inches
Millimeters

Dimensions

Extended Flanged Valve & Hydraulic Cylinder Actuator

Valve Size	Dimensions						
	E	F	G		H	Q	R
			EFS	EFL			
2" 50mm	0.75 19	3.25 83	5.88 149	6.88 175	4.00 102	11.30 287	5.50 140
3" 80mm	0.94 24	3.75 95	5.88 149	6.88 175	4.75 121	12.78 325	8.00 203
4" 100mm	0.94 24	4.50 114	5.88 149	6.88 175	5.00 127	15.06 383	8.25 210
5" 125mm	0.94 24	5.00 127	6.00 152	7.00 178	5.75 146	17.50 445	8.25 210
6" 150mm	1.00 25	5.50 140	6.00 152	7.00 178	5.75 146	19.06 484	8.25 210
8" 200mm	1.12 28	6.75 171	6.25 159	7.25 184	6.38 162	22.56 573	8.50 216
10" 250mm	1.19 30	8.00 203	N/A	8.88 226	8.25 210	28.25 718	9.00 229
12" 300mm	1.25 32	9.50 241	N/A	10.13 257	8.25 210	31.94 811	9.00 229
14" 350mm	1.38 35	10.50 267	N/A	10.13 257	8.25 210	34.50 876	9.00 229
16" 400mm	1.44 37	11.75 298	N/A	11.00 279	8.69 221	38.19 970	9.00 229
18" 450mm	1.56 40	12.50 318	N/A	12.25 311	9.13 232	43.63 1108	9.75 248
20" 500mm	1.69 43	13.75 349	N/A	14.13 359	9.19 233	47.31 1202	9.75 248
24" 600mm	1.87 47	16.00 406	N/A	14.63 372	9.19 233	55.28 1404	10.00 254

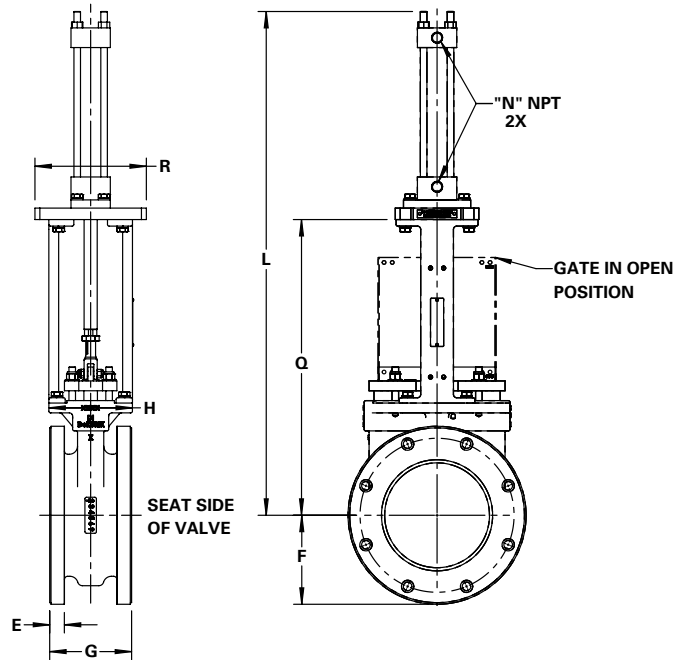

Hydraulic Cylinder Actuator 2-12" Valve Sizes

Actuator Code	Dimensions								N
	L								
	2" 50mm	3" 80mm	4" 100mm	5" 125mm	6" 150mm	8" 200mm	10" 250mm	12" 300mm	
CY-HC1.5	20.27 515	22.78 579	—	—	—	—	—	—	1/2
CY-HC2	—	—	26.69 678	30.13 765	32.71 831	38.44 976	46.28 1176	52.03 1322	1/2
CY-HC2.5	—	—	—	—	—	38.56 979	—	52.16 1325	1/2
CY-HC3.25	—	—	—	—	—	—	47.53 1207	53.29 1354	3/4

Inches
Millimeters



Need Knife Gate Valve pricing or support for your mining project? Contact us for more assistance.

Perth Branch
U2/41-45 Furnace Road
Welshpool WA 6106
Phone: +61 8 9353 2565
sales@thevalvecompany.com.au

Kalgoorlie Branch
2/69 Craig Road
West Kalgoorlie WA 6430
Phone: +61 8 9021 6668
sales@thevalvecompany.com.au

Brisbane Branch
U5/225 Queensport Road
North Murrarie QLD 4172
Phone: +61 7 3348 8636
sales@thevalvecompany.com.au

Bunbury Branch
Phone: +61 417 744 791
sales@thevalvecompany.com.au