

DeZURIK KUL URETHANE LINED KNIFE GATE VALVES

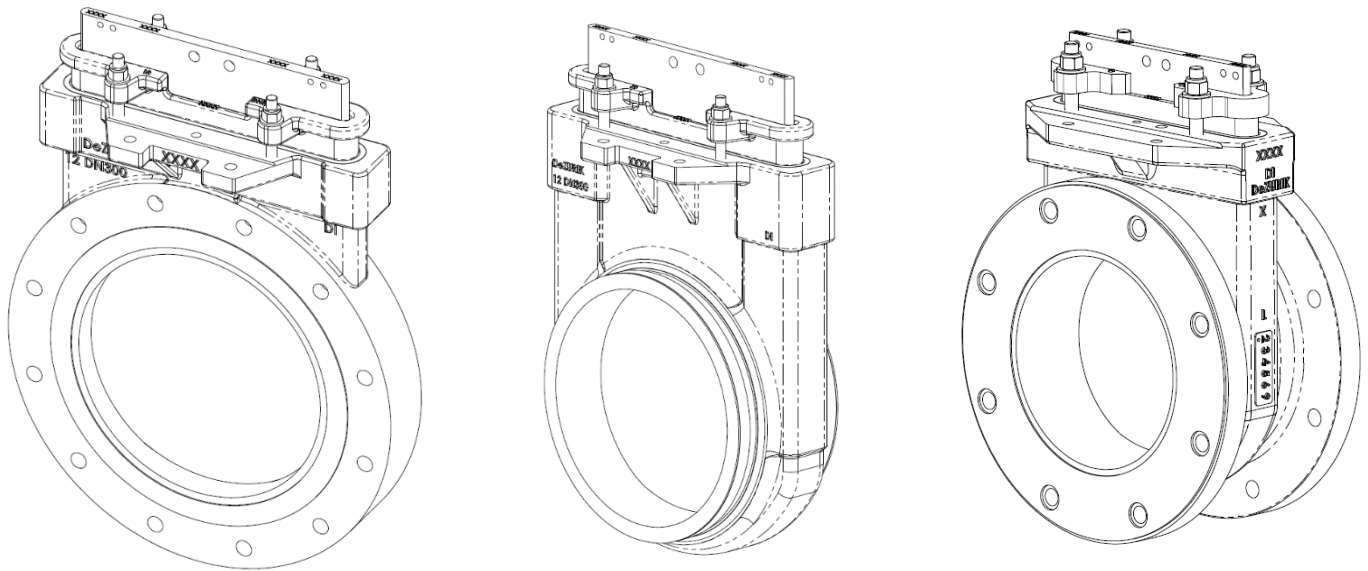

Instruction **D11025**
August 2022

Instructions

These instructions are for use by personnel who are responsible for the installation, operation and maintenance of DeZURIK valves, actuators or accessories.

Safety Messages

All safety messages in the instructions are identified by a general warning sign and the signal word CAUTION, WARNING or DANGER. These messages indicate procedures to avoid injury or death.

Safety label(s) on the product indicate hazards that can cause injury or death. If a safety label becomes difficult to see or read, or if a label has been removed, please contact DeZURIK for replacement label(s).

⚠️WARNING

Personnel involved in the installation or maintenance of valves should be constantly alert to potential emission of pipeline material and take appropriate safety precautions. Always wear suitable protection when dealing with hazardous pipeline materials. Handle valves which have been removed from service with suitable protection for any potential pipeline material in the valve.

Inspection

Your DeZURIK product has been packaged to provide protection during shipment; however, items can be damaged in transport. Carefully inspect the unit for damage upon arrival and file a claim with the carrier if damage is apparent.

Parts

Replaceable wear parts are listed on the assembly drawing. These parts can be stocked to minimize downtime. Order parts from your local DeZURIK sales representative or directly from DeZURIK. When ordering parts please provide the following information:

If the valve has a data plate: please include the 7-digit part number with either 4-digit revision number (example: 9999999R000) or 8-digit serial number (example: S1900001) whichever is applicable. The data plate will be attached to the valve assembly. Also, include the part name, the assembly drawing number, the balloon number and the quantity stated on the assembly drawing.

If there isn't any data plate visible on the valve: please include valve model number, part name, and item number from the assembly drawing. You may contact your local DeZURIK Representative to help you identify your valve.

DeZURIK Service

DeZURIK service personnel are available to maintain and repair all DeZURIK products. DeZURIK also offers customized training programs and consultation services. For more information, contact your local DeZURIK sales representative or visit our website at DeZURIK.com.

Table of Contents

Description	4
Handling	4
Handling	5
Installation for Various End Connections - General.....	6
Installation of Flanged Valves onto Raised Face Flanges	6
Installation of Flanged Valves onto Flat Faced Flanges	7
Installation of Grooved-End Valves	7
Operation	8
Lubrication.....	8
Packing	8
Adjustment	8
Parts Identification.....	9
Packing Replacement.....	10
Removing the Old Packing.....	10
Installing New Packing	10
Reassembling the Valve	11
Replacing the Gate	12
Troubleshooting.....	13

Description

KUL knife gate valves have a urethane-lined, ductile iron body with an embedded moulded seat and gate. Available gate materials include a range of stainless steels or Hastelloy. The KUL knife gate valve is available for 150 psi CWP or 250 psi CWP service. A choice of several actuators and accessories is available.

All sizes of KUL are available with bolted flange connections and sizes 2 -12" (50-200mm) are available with grooved end connections as per ANSI/AWWA C606.

⚠WARNING

A potential hazard exists with handling valves. Failure to handle valves properly may cause a valve to shift, slip or fall causing serious injury or death and/or equipment damage.

Handling

The points below are for reference purposes only; use safe and proper lifting and support techniques. DO NOT lift valves with any adjoining pipe or other equipment attached. Lift with properly rated lifting equipment. Follow jurisdictional safety requirements.

Suggested lifting points are as shown below to lift valve assemblies that are in a horizontal orientation. Eye bolts in flange holes can be used to lift the valve body or, for 2-12" (50-200mm) valves, a sling can be strapped around the top of the valve body.

For valves with bevel gear actuators, a sling or chain can be wrapped around the bevel gear actuator body, between the mounting plate and the input shaft housing. This would be in conjunction with lifting from the valve body as well. See Figure 1.

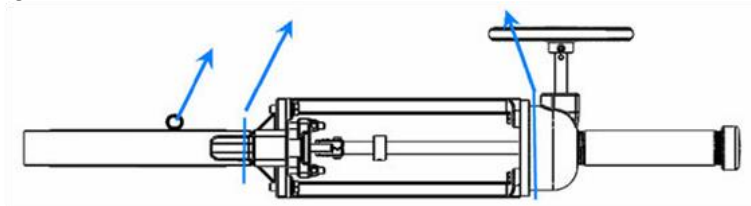

Figure 1 - Knife Gate Valve with Bevel Gear Actuator, Horizontal Lifting

For valves with pneumatic cylinder actuators, a sling can be wrapped around the cylinder, near the cylinder head (piston rod end). This would be in conjunction with lifting from the valve body. Utilize caution to not bump, dent or damage the cylinder tube. DO NOT utilize the cylinder tie-rod ends to lift. See Figure 2.

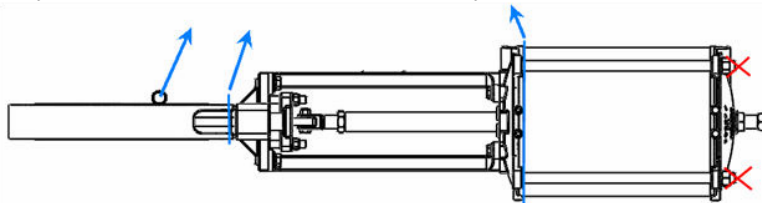

Figure 2 - Knife Gate Valve with Pneumatic Cylinder Actuator, Horizontal Lifting

Handling *continued*

For valves with handwheel actuators, a sling or chain can be wrapped through the rim of the handwheel. For chainwheel actuators, a sling can be wrapped in the area between the yoke/legs and the chainwheel/guide assembly. This would be in conjunction with lifting from the valve body as well. See Figure 3.

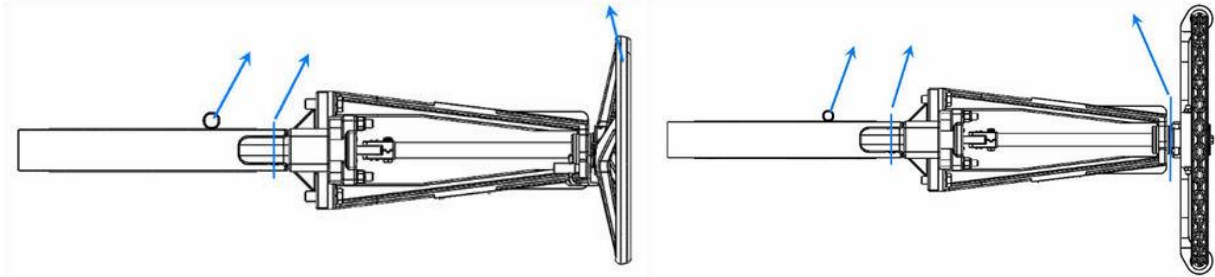

Figure 3 - Knife Gate Valve with Handwheel or Chainwheel Actuator, Horizontal Lifting

Suggested lifting options are as shown below to lift valve assemblies that are in a vertical orientation. For valves with bevel gear actuators, wrap slings or chains around the top of each leg. Use caution not to put any side load on the bevel gear input shaft or on the valve's threaded stem. See Figure 4.

For valves with pneumatic cylinder actuators, wrap slings around the top of each leg. Use caution to not bump, dent or damage the cylinder tube and avoid any side load on the cylinder piston rod. DO NOT utilize the cylinder tie-rod ends to lift. See Figure 5.

For valves with handwheel or chainwheel actuators, wrap slings or chains around the top of each leg or yoke side. Use caution to not put any side load on the valve's threaded stem. See Figure 6.

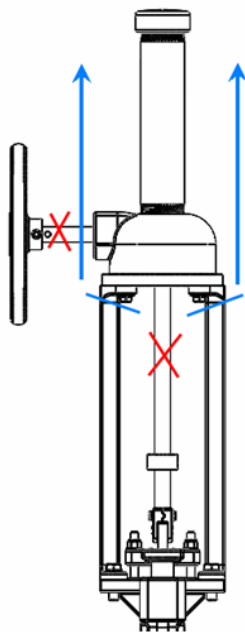

Figure 4 - Knife Gate Valve with Bevel Gear Actuator, Vertical Lifting

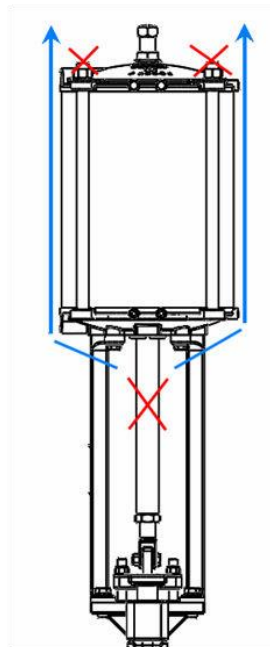

Figure 5 - Knife Gate Valve with Pneumatic Cylinder Actuator, Vertical Lifting

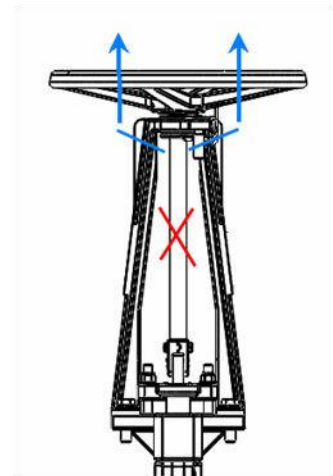

Figure 6 - Knife Gate Valve with Handwheel or Chainwheel Actuator, Vertical Lifting

Installation for Various End Connections - General

Confirm if the KUL knife gate valve is being installed onto raised face flanges, grooved-end connections, or flat faced flanges such as, but not limited to, fiberglass reinforced plastic (FRP)/plastic flanges. There are installation differences that must be adhered to for weaker flange connections as explained in the sections that follow.

Although the KUL is a bi-directional valve, the preferred direction is to install the valve so that the side marked “SEAT” is on the lower pressure side of the valve when the valve is closed; the pipeline pressure will then help seal the valve in the closed position.

After installing the valve, pressurize the pipeline and ensure the packing is not leaking. If the packing leaks, adjust the packing as described under the **Adjustment** section.

It is the responsibility of the user to determine the final torque values and the bolt, flange, and gasket selections, as applicable, to ensure they are stressed within acceptable limits.

WARNING: The suggested guidance for installation and bolt tensioning is advisory only, its use by anyone is voluntary, and users assume all risks. Care should be taken as any fastener torque is only an indirect indication of tension and is affected by several variables outside of DeZURIK’s control. Under/over tightening of fasteners can result in personal injury or costly equipment failure such as, but not limited to flange leakage/damage, bolt failure, gasket under/over compression, chest distortion/seat leakage, gate galling, inability to stroke the gate as designed, and other permanent gate and seat damage.

Installation of Flanged Valves onto Raised Face Flanges

For flanged valves being installed onto raised face flanges, install the valve between ASME Class 125 or Class 150 pipeline raised face flanges or other flanges that match the valve end connection drilling. Use only U.S. customary fasteners with U.S. customary flange drillings and, similarly, use only metric fasteners for metric flange drillings. No gasket is required for raised face flanges.

Before installation:

- Confirm final bolt/stud target torque does not exceed value listed in Table A to prevent distortion of the valve body and gate.
- Remove foreign material such as weld spatter, oil, grease and dirt from the valve and pipeline.

TABLE A: MAXIMUM FLANGE BOLT/STUD TORQUE REGARDLESS OF CONNECTING FLANGE TYPE
FT·LB_f
Nm

VALVE SIZE		NON-LUBRICATED TORQUE	LUBRICATED TORQUE
Inch	mm		
2	50	<u>17</u>	<u>13</u>
		23	17
2.5	65	<u>25</u>	<u>19</u>
		34	25
3	80	<u>32</u>	<u>24</u>
		43	33
4	100	<u>25</u>	<u>19</u>
		34	25
5	125	<u>37</u>	<u>28</u>
		50	38
6	150	<u>47</u>	<u>35</u>
		64	48
8	200	<u>74</u>	<u>56</u>
		100	75
10	250	<u>84</u>	<u>63</u>
		114	85
12	300	<u>120</u>	<u>90</u>
		163	122
14	350	<u>164</u>	<u>123</u>
		222	167
16	400	<u>160</u>	<u>120</u>
		217	163
18	450	<u>202</u>	<u>152</u>
		274	205
20	500	<u>197</u>	<u>148</u>
		267	200
24	600	<u>304</u>	<u>228</u>
		412	309
26	650	<u>295</u>	<u>221</u>
		400	300
28	700	<u>290</u>	<u>218</u>
		393	295
30	750	<u>326</u>	<u>245</u>
		442	331
32	800	<u>443</u>	<u>332</u>
		601	450
36	900	<u>479</u>	<u>359</u>
		649	487
42	1050	<u>574</u>	<u>431</u>
		778	584
48	1200	<u>603</u>	<u>452</u>
		818	613

Observe the following points to prevent distortion of the valve body and gate when the flange bolts are tightened:

- Align the mating pipeline flanges.
- Select the length of the flange bolts/studs so that the bolts/studs used in the blind holes near the chest area of the valve do not bottom out when tightened. We recommend using studs with nuts in the blind holes.
- Tighten the flange bolts evenly, in a crisscross pattern to obtain the final target torque without exceeding the maximum torque listed in Table A as previously mentioned.

Note: Maximum torque values are based on ASME Pressure Vessel Code Calculations, lab test data and the 250-psi pressure rating.

Installation of Flanged Valves onto Flat Faced Flanges

The KUL EFL or EFS extended flange valves have full flat faced flanges and are ideal for installing onto flat faced connections such as FRP, plastic or others. **CAUTION** must be taken for installation of flanged valves onto *weaker* flange materials such as FRP or plastic. The maximum flange bolt/stud torque to prevent damage to flanges of FRP or plastic material are much lower than those used with stronger steel or iron flat faced flanges.

DeZURIK recommends the use of soft rubber gaskets when KUL EFL/EFS are installed onto flat faced flanges regardless of the flanges' materials of construction. The user is responsible for the final flange bolt/stud torques which should be based on the connecting flange and gasket manufacturer's recommendations but should never exceed the torques specified in Table A to prevent distortion of the valve body and gate.

Installation of Grooved-End Valves

KUL knife gate valves for sizes 2-12" (50-200mm) are available with grooved ends. There are three different groove end styles: V7 as per AWWA C606-15 table 4; VF (flexible) as per AWWA C606-15 table 2; and VR (rigid) as per AWWA C606-15 table 3.

When installing a grooved end valve, follow the instructions supplied with the coupling. If using two flexible couplings, support may be required to prevent valve rotation.

DeZURIK

KUL Urethane Lined Knife Gate Valve

Operation

The gate in the valve is positioned by the valve actuator. The actuator moves the gate over the valve port in the closed position and withdraws the gate from the valve port to the open position. Refer to the Actuator Instructions for adjustment and maintenance requirements for the actuator.

Lubrication

The valve does not require lubrication. Refer to the Actuator Instructions for lubrication requirements for the actuator.

Packing

The gate packing is contained and compressed by the packing gland. There are various packing arrangement options available for the KUL which include SMP, ASP, TDP, FGP and NXS. See Figure 7 for component identification and illustrations of the packing arrangements.

Adjustment

If packing leaks, tighten the adjustment nuts on top of the packing gland. Tighten the nuts evenly and gently, just enough to stop the leak. Over tightening will cause excessive operating forces, and will decrease the life of the packing.

Parts Identification

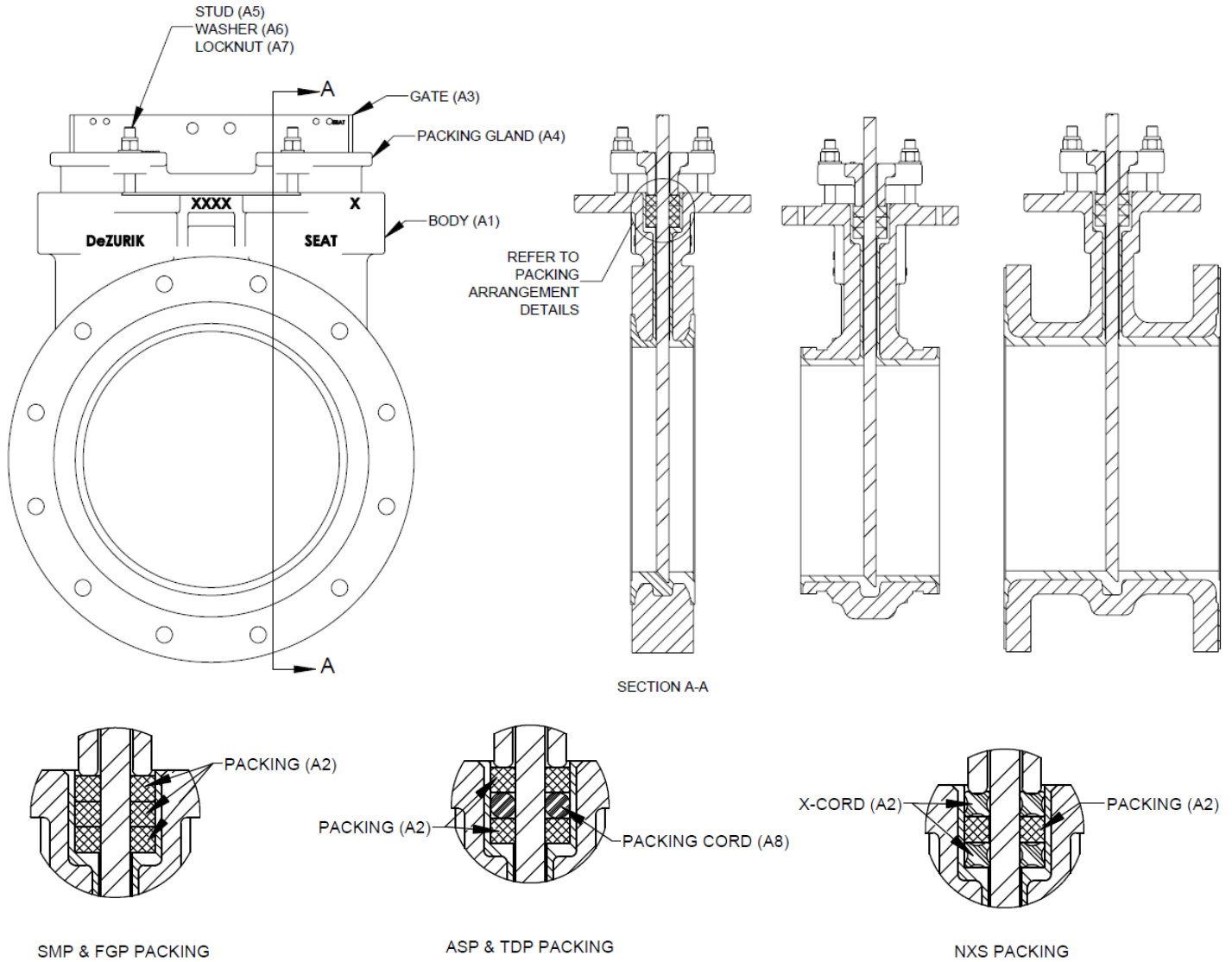

Figure 7 – Component Identification
(Identical between Flanged and Grooved-End Valves)

Packing Replacement

Removing the Old Packing

1. Relieve the pressure in the pipeline and close the valve.

▲WARNING

Pipeline pressure can cause personal injury or equipment damage. Relieve pipeline pressure before removing gate stem and packing gland nuts.

2. If the actuator is powered, disconnect and lock out power to prevent accidental operation of the actuator.

▲WARNING

Accidental operation of a power actuator can cause personal injury or equipment damage. Disconnect and lock out power to actuator before servicing.

3. Remove the two screws and nuts near the top of the gate and disengage the stem from the gate by stroking the actuator (not the valve) to the open position.
4. Remove the gland locknuts (A7) and washers (A6) and gland (A4).
5. Remove the packing (A2) and, if provided, packing cord (A8), from the valve body's packing chamber.

Installing New Packing

Packing (A2) layer length and quantity are shown in Table B. Ensure the inside and outside edges of each layer are packed against the gate and packing chamber so that each layer is compressed flat and evenly. DeZURIK provides extra packing in the packing kits, but do not try to put more packing into a layer than shown in Table B.

1. Ensure the gate (A3) is fully closed and centered in the body before packing.
2. Assemble and pack the layers one at a time, ensuring the ends butt together but do not overlap.

Note: Stagger the joints on the long side of the packing chamber. Use a square-ended wood or plastic tool, driven by a hammer or mallet to pack rings into the chamber. Do not use a sharp metal tool to pack the rings.

- For ASP and TDP packing arrangements with the packing cord (A8), install and pack one row of packing (A2) and then insert the packing cord (A8), followed by the last row of packing (A2). Refer to the packing arrangement illustration in Figure 7.

- For the NXS packing arrangement, install one row of the rubber X-cord (A2), ensuring that it does not twist and then insert the standard packing (A2), followed by the top rubber X-cord layer. Refer to the packing arrangement illustration in Figure 7. For NXS packing in valve sizes 2" through 16", the recommended torque on the gland nuts (A7) would be 250in·lb [29Nm]. For NXS packing in valve sizes 18" and greater, the recommended torque on the gland nuts (A7) would be 450in·lb [51Nm]. However, gland nuts should be evenly tightened to the recommended torque and, if there is leakage through the packing, increase torque gradually.

Table B: Packing and Cord Layer Length and Quantity

Valve Size	Packing Size	Layer Length		Layer Quantity				
		Inches	Mm	w/o Cord	with Cord	Cord	NXS	
							X-Cord	Packing
2	3/8"	7.50	191	3	2	1	2	1
2.5		9.50	241					
3		9.50	241					
4		11.50	292					
5		13.50	343					
6		15.50	394					
8		20.00	508					
10		1/2"	25.00					
12	29.00		737					
14	32.00		813					
16	36.75		933					
18	5/8"	41.25	1048					
20		45.25	1149					
24		53.50	1359					
26		58.00	1473					
28		63.50	1613					
30		3/4"	66.25					
32	72.50		1842					
36	79.00		2007					
42	92.00		2337					
48	105.50		2680					

Reassembling the Valve

- Replace the packing gland (A4), locknuts (A7) and washers (A6). Tighten the locknuts (A7) evenly and finger tight, plus 1/2 turn.
- Reconnect the stem to the gate with the two screws and nuts.
- If the actuator is a powered actuator, reconnect power to the actuator.
- Pressurize the pipeline and inspect packing for leakage.
- If packing leaks, tighten the adjustment locknuts (A7) on top of the packing gland. Tighten the locknuts evenly and gently - just enough to stop the leak. Over tightening will cause excessive operating forces, and will decrease the life of the packing.

Replacing the Gate

NOTICE

Gates 6" and larger are not interchangeable between KUL and KUL-EF valves. Contact DeZURIK to ensure any substitutions between valve types is appropriate.

See Figure 7 for component identification.

1. Relieve the pressure in the pipeline and close the valve.
-

▲WARNING

Pipeline pressure can cause personal injury or equipment damage. Relieve pipeline pressure before removing gate stem and packing gland nuts.

2. If the actuator is powered, disconnect and lock out power to prevent accidental operation of the actuator.
-

▲WARNING

Accidental operation of a power actuator can cause personal injury or equipment damage. Disconnect and lock out power to actuator before servicing.

3. Remove the pipeline flange bolts, or grooved-end couplings, and remove the valve from the pipeline.
4. Remove the actuator, actuator yoke, packing gland (A4), packing (A2) and packing cord (A8), if provided, from the valve.
5. Remove and inspect the gate (A3). If the gate appears to be scratched or galled due to the flange bolts in the chest area of the body being too long, check for body damage in the tapped flange holes and within the chest cavity. Carefully check the urethane lining for damage. Repair or replace the body, as appropriate.
6. Place the new gate (A3) in the body, in the fully closed position.
7. Replace or reinstall the provided packing arrangement as described in **Installing New Packing** section.
8. Replace the yoke and actuator on the valve.
9. Adjust the actuator, yoke and packing gland so that the valve actuates smoothly through the full stroke in both directions, and so that there is no evidence of binding on the gate when the gate is visible in the fully open position.
10. Reinstall the valve in the pipeline, see **Installation** section.
11. If the actuator is a powered actuator, reconnect power to the actuator.
12. Pressurize the pipeline and inspect the valve for leaks.
13. If the packing leaks, tighten the adjustment locknuts (A7) on top of the packing gland, see **Adjustment** section.

Troubleshooting

Condition	Possible Causes	Corrective Action
Packing leaks with no evidence of galling on gate	Packing is loose	Adjust packing gland
	Packing is worn or torn	Replace packing
Packing leaks and gate is galled	Packing is worn or torn	Replace packing and gate, check lining for damage
Valve leaks when fully closed with no evidence of galling on gate	Urethane liner seat is worn or torn	Replace urethane lined valve body
Valve leaks when fully closed and gate is galled	Urethane liner seat is worn or torn	Replace gate and urethane lined valve body

Limited Warranty

DeZURIK, Inc. ("Seller") manufactured products, auxiliaries and parts thereof that we manufacture for a period of twenty-four (24) months from date of shipment from Seller's factory, are warranted to the original purchaser only against defective workmanship and material, but only if properly stored, installed, operated, and serviced in accordance with Seller's recommendations and instructions.

For items proven to be defective within the warranty period, your exclusive remedy under this limited warranty is repair or replacement of the defective item, at Seller's option, FCA Incoterms 2020 Seller's facility with removal, transportation, and installation at your cost.

Products or parts manufactured by others but furnished by Seller are not covered by this limited warranty. Seller may provide repair or replacement for other's products or parts only to the extent provided in and honored by the original manufacturer's warranty to Seller, in each case subject to the limitations contained in the original manufacturer's warranty.

No claim for transportation, labor, or special or consequential damages or any other loss, cost or damage is being provided in this limited warranty. You shall be solely responsible for determining suitability for use and in no event shall Seller be liable in this respect.

This limited warranty does not warrant that any Seller product or part is resistant to corrosion, erosion, abrasion or other sources of failure, nor does Seller warrant a minimum length of service.

Your failure to give written notice to us of any alleged defect under this warranty within twenty (20) days of its discovery, or attempts by someone other than Seller or its authorized representatives to remedy the alleged defects therein, or failure to return product or parts for repair or replacement as herein provided, or failure to store, install, or operate said products and parts according to the recommendations and instructions furnished by Seller shall be a waiver by you of all rights under this limited warranty.

This limited warranty is voided by any misuse, modification, abuse or alteration of Seller's product or part, accident, fire, flood or other Act of God, or your failure to pay entire contract price when due.

The foregoing limited warranty shall be null and void if, after shipment from our factory, the item is modified in any way or a component of another manufacturer, such as but not limited to; an actuator is attached to the item by anyone other than a Seller factory authorized service personnel.

All orders accepted shall be deemed accepted subject to this limited warranty, which shall be exclusive of any other or previous warranty, and this shall be the only effective guarantee or warranty binding on Seller, despite anything to the contrary contained in the purchase order or represented by any agent or employee of Seller in writing or otherwise, notwithstanding, including but not limited to implied warranties.

THE FOREGOING REPAIR AND REPLACEMENT LIMITED WARRANTY IS IN LIEU OF ALL OTHER WARRANTIES, OBLIGATIONS AND LIABILITIES, INCLUDING, BUT NOT LIMITED TO, ALL WARRANTIES OF FITNESS FOR A PARTICULAR PURPOSE OR OF MERCHANTABILITY OR OTHERWISE, EXPRESSED OR IMPLIED IN FACT OR BY LAW, AND STATE SELLER'S ENTIRE AND EXCLUSIVE LIABILITY AND YOUR EXCLUSIVE REMEDY FOR ANY CLAIM IN CONNECTION WITH THE SALE AND FURNISHING OF SERVICES, GOODS OR PARTS, THEIR DESIGN, SUITABILITY FOR USE, INSTALLATION OR OPERATIONS. NEITHER ANY PERFORMANCE OR OTHER CONDUCT, NOR ANY ORAL OR WRITTEN INFORMATION, STATEMENT, OR ADVICE PREPARED BY SELLER OR ANY OF OUR EMPLOYEES OR AGENTS WILL CREATE A WARRANTY, OR IN ANY WAY INCREASE THE SCOPE OR DURATION OF THE LIMITED WARRANTY.

Disclaimer

Metric fasteners should not be used with ASME Class 150/300 bolt holes and flange bolt patterns. If you use metric fasteners with ASME Class 150/300 bolt holes and flange bolt patterns, it may lead to product failure, injury, and loss of life. DeZURIK Inc. disclaims all liability associated with the use of metric fasteners with ASME Class 150/300 bolt holes and flange patterns, including but not limited to personal injury, loss of life, loss of product, production time, equipment, property damage, lost profits, consequential damages of any kind and environment damage and/or cleanup. Use of metric fasteners with ASME Class 150/300 bolt holes and flange bolt patterns is a misuse that voids all warranties and contractual assurances. If you use metric fasteners with ASME Class 150/300 bolt holes and flange bolt patterns, you do so at your sole risk and any liability associated with such use shall not be the responsibility of DeZURIK, Inc. In addition to the foregoing, DeZURIK's Manufacturer's Conditions apply.

Limitation of Liability

IN NO EVENT SHALL SELLER BE LIABLE FOR ANY DIRECT, INDIRECT, SPECIAL, PUNITIVE, EXEMPLARY, OR CONSEQUENTIAL DAMAGES (INCLUDING, BUT NOT LIMITED TO; DAMAGE TO OR LOSS OF OTHER PROPERTY OR EQUIPMENT, BUSINESS INTERRUPTION, COST OF SUBSTITUTE PRODUCTS, LOSS OF TIME, LOSS OF PROFITS OR REVENUE, COST OF CAPITAL, LOSS OF USE, OR DIMINUTION IN VALUE) WHATSOEVER, AND SELLER'S LIABILITY, UNDER NO CIRCUMSTANCES, WILL EXCEED THE CONTRACT PRICE FOR THE GOODS AND/OR SERVICES FOR WHICH LIABILITY IS CLAIMED. ANY ACTION FOR BREACH OF CONTRACT BY YOU, OTHER THAN RIGHTS RESPECTING OUR LIMITED WARRANTY DESCRIBED ABOVE, MUST BE COMMENCED WITHIN 12 MONTHS AFTER THE DATE OF SALE.



Need Knife Gate Valve pricing or support for your mining project? Contact us for more assistance.

Perth Branch
U2/41-45 Furnace Road
Welshpool WA 6106
Phone: +61 8 9353 2565
sales@thevalvecompany.com.au

Kalgoorlie Branch
2/69 Craig Road
West Kalgoorlie WA 6430
Phone: +61 8 9021 6668
sales@thevalvecompany.com.au

Brisbane Branch
U5/225 Queensport Road
North Murrarie QLD 4172
Phone: +61 7 3348 8636
sales@thevalvecompany.com.au

Bunbury Branch
Phone: +61 417 744 791
sales@thevalvecompany.com.au