

# KGC Cast Knife Gate Valve Safety Manual

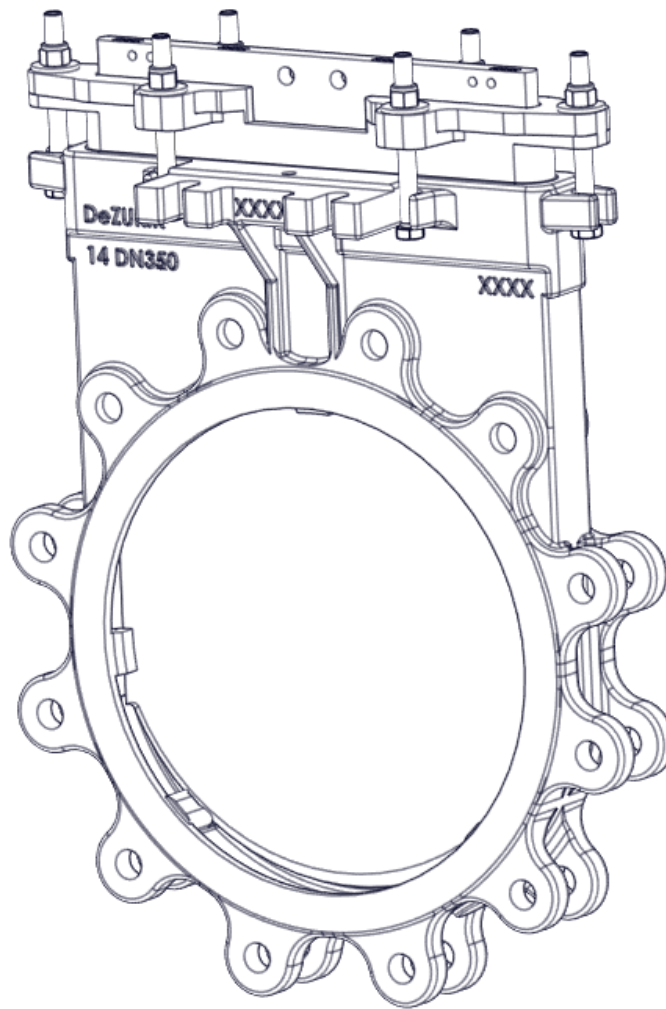

Instruction **D11036**  
August 2014

### Table of Contents

1	Introduction.....	3
1.1	Terms.....	3
1.2	Abbreviations .....	4
1.3	Product Support .....	4
1.4	Related Literature.....	4
1.5	Reference Standards .....	5
2	Device Description.....	5
3	Designing a SIF Using a Customer Product .....	5
3.1	Safety Function .....	5
3.2	Environmental limits .....	5
3.3	Application limits .....	5
3.4	Design Verification .....	6
3.5	SIL Capability.....	6
3.5.1	Systematic Integrity .....	6
3.5.2	Random Integrity .....	6
3.5.3	Safety Parameters.....	6
3.6	Connection of the DeZURIK KGC Cast knife gate valves to the SIS Logic-solver .....	6
3.7	General Requirements .....	7
4	Installation and Commissioning.....	7
4.1	Installation.....	7
4.2	Physical Location and Placement.....	7
5	Operations and Maintenance.....	7
5.1	Proof test without automatic testing.....	7
5.2	Suggested Proof Test.....	8
5.3	Proof Test Coverage .....	8
5.4	Repair and replacement.....	9
5.5	Useful Life.....	9
5.6	Manufacture Notification.....	9
6	Status of the Document .....	9
6.1	Releases.....	9
6.2	Future Enhancements.....	9
6.3	Release Signatures.....	9

### 1. Introduction

This Safety Manual provides information necessary to design, install, verify and maintain a Safety Instrumented Function (SIF) utilizing the DeZURIK KGC Cast knife gate valves. This manual provides necessary requirements for meeting the IEC 61508 or IEC 61511 functional safety standards.

#### 1.1 Terms

Safety	Freedom from unacceptable risk of harm
Functional Safety	The ability of a system to carry out the actions necessary to achieve or to maintain a defined safe state for the equipment / machinery / plant / apparatus under control of the system
Basic Safety	The equipment must be designed and manufactured such that it protects against risk of damage to persons by electrical shock and other hazards and against resulting fire and explosion. The protection must be effective under all conditions of the nominal operation and under single fault condition
Safety Assessment	The investigation to arrive at a judgment - based on evidence - of the safety achieved by safety-related systems
Fail-Safe State	State where solenoid valve is de-energized and spring is extended.
Fail Safe	Failure that causes the valve to go to the defined fail-safe state without a demand from the process.
Fail Dangerous	Failure that does not respond to a demand from the process (i.e. being unable to go to the defined fail-safe state).
Fail Dangerous Undetected	Failure that is dangerous and that is not being diagnosed by automatic stroke testing.
Fail Dangerous Detected	Failure that is dangerous but is detected by automatic stroke testing.
Fail Annunciation Undetected	Failure that does not cause a false trip or prevent the safety function but does cause loss of an automatic diagnostic and is not detected by another diagnostic.
Fail Annunciation Detected	Failure that does not cause a false trip or prevent the safety function but does cause loss of an automatic diagnostic or false diagnostic indication.
Fail No Effect	Failure of a component that is part of the safety function but that has no effect on the safety function.
Low demand mode	Mode, where the frequency of demands for operation made on a safety-related system is no greater than twice the proof test frequency.

### 1.2 Abbreviations

FMEDA	Failure Modes, Effects and Diagnostic Analysis
HFT	Hardware Fault Tolerance
MOC	Management of Change. These are specific procedures often done when performing any work activities in compliance with government regulatory authorities.
PFDavg	Average Probability of Failure on Demand
SFF	Safe Failure Fraction, the fraction of the overall failure rate of a device that results in either a safe fault or a diagnosed unsafe fault.
SIF	Safety Instrumented Function, a set of equipment intended to reduce the risk due to a specific hazard (a safety loop).
SIL	Safety Integrity Level, discrete level (one out of a possible four) for specifying the safety integrity requirements of the safety functions to be allocated to the E/E/PE safety-related systems where Safety Integrity Level 4 has the highest level of safety integrity and Safety Integrity Level 1 has the lowest.
SIS	Safety Instrumented System – Implementation of one or more Safety Instrumented Functions. A SIS is composed of any combination of sensor(s), logic solver(s), and final element(s).

### 1.3 Product Support

Product support can be obtained from:

DeZURIK  
385 Franklin Blvd  
P.O. Box 430  
Cambridge, Ontario  
N1R 5V5  
Canada

### 1.4 Related Literature

Hardware Documents:

- DeZURIK KGC Cast knife gate valves Installation, Operation and Maintenance Instructions

Guidelines/References:

- Safety Integrity Level Selection – Systematic Methods Including Layer of Protection Analysis, ISBN 1-55617-777-1, ISA
- Control System Safety Evaluation and Reliability, 2nd Edition, ISBN 1-55617-638-8, ISA

- Safety Instrumented Systems Verification, Practical Probabilistic Calculations, ISBN 1-55617-909-9, ISA

### 1.5 Reference Standards

#### Functional Safety

- IEC 61508: 2000 Functional safety of electrical/electronic/ programmable electronic safety-related systems
- ANSI/ISA 84.00.01-2004 (IEC 61511 Mod.) Functional Safety – Safety Instrumented Systems for the Process Industry Sector

## 2 Device Description

- DeZURIK KGC-ES Cast Stainless Steel Knife Gate Valves are designed for the toughest corrosive, abrasive liquid, slurry or dry material applications including: Pulp and Paper, Mining, Waste Water,
- Chemical, Petrochemical, Power, Steel, Food Processing, etc. KGC-ES Knife Gate Valves are available in sizes 2" - 48" (50mm - 1200mm) with metal or resilient seated versions. The actuator superstructure is heavy duty cast carbon steel or cast stainless steel to minimize corrosion. A variety of actuator options are available including: handwheels, chainwheels, bevel gears, levers, pneumatic cylinders, hydraulic cylinders, and electric motors. A full complement of accessories is also offered.

## 3 Designing a SIF Using a Customer Product

### 3.1 Safety Function

When de-energized, the actuator moves the valve to their fail-safe position. Depending on the version specified Fail – Closed or Fail - Open, the valve will rotate the valve plug to close off the flow path through the valve body or open the flow path through the valve body.

The valve is intended to be part of final element subsystem as defined per IEC 61508 and the achieved SIL level of the designed function must be verified by the designer.

### 3.2 Environmental limits

The designer of a SIF must check that the product is rated for use within the expected environmental limits. Refer to the DeZURIK KGC Cast knife gate valves Brochure for environmental limits.

### 3.3 Application limits

The materials of construction of DeZURIK KGC Cast knife gate valves are specified in the DeZURIK brochure. It is especially important that the designer check for material compatibility considering on-site chemical contaminants and air supply conditions. If the DeZURIK KGC knife gate valve is used outside of the application limits or with incompatible materials, the reliability data provided becomes invalid.

### 3.4 Design Verification

A detailed Failure Mode, Effects, and Diagnostics Analysis (FMEDA) report is available from DeZURIK . This report details all failure rates and failure modes as well as the expected lifetime.

The achieved Safety Integrity Level (SIL) of an entire Safety Instrumented Function (SIF) design must be verified by the designer via a calculation of PFDAVG considering architecture, proof test interval, proof test effectiveness, any automatic diagnostics, average repair time and the specific failure rates of all products included in the SIF. Each subsystem must be checked to assure compliance with minimum hardware fault tolerance (HFT) requirements.

When using DeZURIK KGC Cast knife gate valves in a redundant configuration, a common cause factor of at least 5% should be included in safety integrity calculations.

The failure rate data listed the FMEDA report is only valid for the useful life time of a DeZURIK KGC Cast knife gate valves. The failure rates will increase sometime after this time period. Reliability calculations based on the data listed in the FMEDA report for mission times beyond the lifetime may yield results that are too optimistic, i.e. the calculated Safety Integrity Level will not be achieved.

### 3.5 SIL Capability

#### 3.5.1 Systematic Integrity

The product has met manufacturer design process requirements of Safety Integrity Level (SIL) 3. These are intended to achieve sufficient integrity against systematic errors of design by the manufacturer. A Safety Instrumented Function (SIF) designed with this product must not be used at a SIL level higher than the statement without “prior use” justification by end user or diverse technology redundancy in the design.

#### 3.5.2 Random Integrity

The failure rate data used for this analysis meets the *exida* criteria for Route 2<sub>H</sub>. Therefore the KGC Cast Stainless Steel Knife Gate Valve can be classified as a 2<sub>H</sub> device when the listed failure rates are used. When 2<sub>H</sub> data is used for all of the devices in an element, then the element meets the hardware architectural constraints up to SIL 2 at HFT=0 (or SIL 3 @ HFT=1) per Route 2<sub>H</sub>. If Route 2<sub>H</sub> is not applicable for the entire final element, the architectural constraints will need to be evaluated per Route 1<sub>H</sub>.

#### 3.5.3 Safety Parameters

For detailed failure rate information refer to the Failure Modes, Effects and Diagnostic Analysis Report for the DeZURIK KGC Cast knife gate valves.

### 3.6 Connection of the DeZURIK KGC Cast knife gate valves to the SIS Logic-solver

There is no direct connection to the SIS logic-solver to KGC knife gate valves; however it may be part of final element which would be actuators, solenoid valves or any control devices that are connected to the KGC valve assembly.

### 3.7 General Requirements

All SIS components including the DeZURIK KGC Cast knife gate valves must be operational before process start-up.

User shall verify that the DeZURIK KGC Cast knife gate valves is suitable for use in safety applications by confirming the DeZURIK KGC Cast knife gate valves nameplates are properly marked.

Personnel performing maintenance and testing on the DeZURIK KGC Cast knife gate valves shall be competent to do so.

Results from the proof tests shall be recorded and reviewed periodically.

The useful life of the DeZURIK KGC Cast knife gate valves is discussed in the Failure Modes, Effects and Diagnostic Analysis Report.

## 4 Installation and Commissioning

### 4.1 Installation

The valve must be installed as per standard practices outlined in the Installation Manual D10411. The environment must be checked to verify that environmental conditions do not exceed the ratings. The valve must be accessible for physical inspection.

### 4.2 Physical Location and Placement

The valve shall be accessible with sufficient room for pneumatic connections and shall allow manual proof testing.

Pneumatic piping to the valve shall be kept as short and straight as possible to minimize the airflow restrictions and potential clogging. Long or kinked pneumatic tubes may also increase the valve closure time.

The valve shall be mounted in a low vibration environment. If excessive vibration can be expected special precautions shall be taken to ensure the integrity of pneumatic connectors or the vibration should be reduced using appropriate damping mounts.

## 5 Operations and Maintenance

### 5.1 Proof testing

The objective of proof testing is to detect failures within DeZURIK KGC Cast knife gate valves that are not detected by any automatic diagnostics of the system. The primary concern is undetected failures that prevent the safety instrumented function from performing its intended function.

The frequency of proof testing, or the proof test interval, is to be determined in reliability calculations for the safety instrumented functions for which a DeZURIK KGC Cast knife gate valves is applied. The proof tests must be performed more frequently than or as frequently as specified in the calculation in order to maintain the required safety integrity of the safety instrumented function.

The following proof test is recommended. The results of the proof test should be recorded and any failures that are detected and that compromise functional safety should be reported to DeZURIK .

## 5.2 Suggested Proof Test

The suggested proof test consists of a full stroke of the valve, see Table 1. The Proof Test Coverage for this test is listed in Table 2.

Table 1 Suggested Proof Test

Step	Action
1.	Bypass the safety function and take appropriate action to avoid a false trip.
2.	Interrupt or change the signal/supply to the actuator to force the actuator and valve to the Fail-Safe state and confirm that the Safe State was achieved and within the correct time.
3.	Re-store the supply/signal to the actuator and inspect for any visible damage or contamination and confirm that the normal operating state was achieved.
4.	Inspect the valve for any leaks, visible damage or contamination.
5.	Remove the bypass and otherwise restore normal operation.

For the test to be effective the movement of the valve must be confirmed. To confirm the effectiveness of the test both the travel of the valve and slew rate must be monitored and compared to expected results to validate the testing.

## 5.3 Proof Test Coverage

The Proof Test Coverage for the various product configurations is given in Table 2.

Table 2 Proof Test Coverage- KGC Cast Stainless Steel Knife Gate Valve

Device	Application	No PVST	with PVST
KGC Cast Stainless Steel Knife Gate Valve, Clean Service	Close On Trip- Full Stroke	65%	38%
	Close On Trip- Tight Shutoff	19%	7%
	Open On Trip	80%	57%
KGC Cast Stainless Steel Knife Gate Valve, Severe Service	Close On Trip- Full Stroke	60%	34%
	Close On Trip- Tight Shutoff	14%	5%
	Open On Trip	82%	60%

Table1: Recommended Proof Test

This test will detect >70% of possible DU failures in the valve for the Full Stroke options. (For the Tight Shutoff and Open to Trip options the proof test coverage is >25%, and > 90% respectively).



# DeZURIK

## KGC Cast Knife Gate Valve Safety Manual

---

The person(s) performing the proof test of a DeZURIK KGC Cast knife gate valves should be trained in SIS operations, including bypass procedures, valve maintenance and company Management of Change procedures. No special tools are required.

### 5.4 Repair and replacement

Repair procedures in the DeZURIK KGC Cast knife gate valves Installation, Operation and Maintenance manual must be followed.

### 5.5 Useful Life

The useful life of the KGC knife gate valve is 5 to 10 years, or 10,000 cycles

### 5.6 Manufacture Notification

Any failures that are detected and that compromise functional safety should be reported to DeZURIK . Please contact DeZURIK customer service.

## 6 Status of the Document

### 6.1 Releases

Version: V1  
Revision: R1  
Version History: V1, R1: Released, August 29, 2014  
V0, R1: Draft; January 7, 2014  
Authors: Sidney Watterodt  
Review: V0, R1: Reviewer; January 8, 2014  
Release status: Released

### 6.2 Future Enhancements

At request of project.

### 6.3 Release Signatures

 *I.S. Watterodt*, Design & Continuation Engineer

Name, Title



## Limited Warranty

DeZURIK, Inc. ("Seller") manufactured products, auxiliaries and parts thereof that we manufacture for a period of twenty-four (24) months from date of shipment from Seller's factory, are warranted to the original purchaser only against defective workmanship and material, but only if properly stored, installed, operated, and serviced in accordance with Seller's recommendations and instructions.

For items proven to be defective within the warranty period, your exclusive remedy under this limited warranty is repair or replacement of the defective item, at Seller's option, FCA Incoterms 2020 Seller's facility with removal, transportation, and installation at your cost.

Products or parts manufactured by others but furnished by Seller are not covered by this limited warranty. Seller may provide repair or replacement for other's products or parts only to the extent provided in and honored by the original manufacturer's warranty to Seller, in each case subject to the limitations contained in the original manufacturer's warranty.

No claim for transportation, labor, or special or consequential damages or any other loss, cost or damage is being provided in this limited warranty. You shall be solely responsible for determining suitability for use and in no event shall Seller be liable in this respect.

This limited warranty does not warrant that any Seller product or part is resistant to corrosion, erosion, abrasion or other sources of failure, nor does Seller warrant a minimum length of service.

Your failure to give written notice to us of any alleged defect under this warranty within twenty (20) days of its discovery, or attempts by someone other than Seller or its authorized representatives to remedy the alleged defects therein, or failure to return product or parts for repair or replacement as herein provided, or failure to store, install, or operate said products and parts according to the recommendations and instructions furnished by Seller shall be a waiver by you of all rights under this limited warranty.

This limited warranty is voided by any misuse, modification, abuse or alteration of Seller's product or part, accident, fire, flood or other Act of God, or your failure to pay entire contract price when due.

The foregoing limited warranty shall be null and void if, after shipment from our factory, the item is modified in any way or a component of another manufacturer, such as but not limited to; an actuator is attached to the item by anyone other than a Seller factory authorized service personnel.

All orders accepted shall be deemed accepted subject to this limited warranty, which shall be exclusive of any other or previous warranty, and this shall be the only effective guarantee or warranty binding on Seller, despite anything to the contrary contained in the purchase order or represented by any agent or employee of Seller in writing or otherwise, notwithstanding, including but not limited to implied warranties.

THE FOREGOING REPAIR AND REPLACEMENT LIMITED WARRANTY IS IN LIEU OF ALL OTHER WARRANTIES, OBLIGATIONS AND LIABILITIES, INCLUDING, BUT NOT LIMITED TO, ALL WARRANTIES OF FITNESS FOR A PARTICULAR PURPOSE OR OF MERCHANTABILITY OR OTHERWISE, EXPRESSED OR IMPLIED IN FACT OR BY LAW, AND STATE SELLER'S ENTIRE AND EXCLUSIVE LIABILITY AND YOUR EXCLUSIVE REMEDY FOR ANY CLAIM IN CONNECTION WITH THE SALE AND FURNISHING OF SERVICES, GOODS OR PARTS, THEIR DESIGN, SUITABILITY FOR USE, INSTALLATION OR OPERATIONS. NEITHER ANY PERFORMANCE OR OTHER CONDUCT, NOR ANY ORAL OR WRITTEN INFORMATION, STATEMENT, OR ADVICE PREPARED BY SELLER OR ANY OF OUR EMPLOYEES OR AGENTS WILL CREATE A WARRANTY, OR IN ANY WAY INCREASE THE SCOPE OR DURATION OF THE LIMITED WARRANTY.

## Disclaimer

Metric fasteners should not be used with ASME Class 150/300 bolt holes and flange bolt patterns. If you use metric fasteners with ASME Class 150/300 bolt holes and flange bolt patterns, it may lead to product failure, injury, and loss of life. DeZURIK Inc. disclaims all liability associated with the use of metric fasteners with ASME Class 150/300 bolt holes and flange patterns, including but not limited to personal injury, loss of life, loss of product, production time, equipment, property damage, lost profits, consequential damages of any kind and environment damage and/or cleanup. Use of metric fasteners with ASME Class 150/300 bolt holes and flange bolt patterns is a misuse that voids all warranties and contractual assurances. If you use metric fasteners with ASME Class 150/300 bolt holes and flange bolt patterns, you do so at your sole risk and any liability associated with such use shall not be the responsibility of DeZURIK, Inc. In addition to the foregoing, DeZURIK's Manufacturer's Conditions apply.

## Limitation of Liability

IN NO EVENT SHALL SELLER BE LIABLE FOR ANY DIRECT, INDIRECT, SPECIAL, PUNITIVE, EXEMPLARY, OR CONSEQUENTIAL DAMAGES (INCLUDING, BUT NOT LIMITED TO; DAMAGE TO OR LOSS OF OTHER PROPERTY OR EQUIPMENT, BUSINESS INTERRUPTION, COST OF SUBSTITUTE PRODUCTS, LOSS OF TIME, LOSS OF PROFITS OR REVENUE, COST OF CAPITAL, LOSS OF USE, OR DIMINUTION IN VALUE) WHATSOEVER, AND SELLER'S LIABILITY, UNDER NO CIRCUMSTANCES, WILL EXCEED THE CONTRACT PRICE FOR THE GOODS AND/OR SERVICES FOR WHICH LIABILITY IS CLAIMED. ANY ACTION FOR BREACH OF CONTRACT BY YOU, OTHER THAN RIGHTS RESPECTING OUR LIMITED WARRANTY DESCRIBED ABOVE, MUST BE COMMENCED WITHIN 12 MONTHS AFTER THE DATE OF SALE.



Need Knife Gate Valve pricing or support for your mining project? Contact us for more assistance.

**Perth Branch**  
U2/41-45 Furnace Road  
Welshpool WA 6106  
Phone: +61 8 9353 2565  
sales@thevalvecompany.com.au

**Kalgoorlie Branch**  
2/69 Craig Road  
West Kalgoorlie WA 6430  
Phone: +61 8 9021 6668  
sales@thevalvecompany.com.au

**Brisbane Branch**  
U5/225 Queensport Road  
North Murrarie QLD 4172  
Phone: +61 7 3348 8636  
sales@thevalvecompany.com.au

**Bunbury Branch**  
Phone: +61 417 744 791  
sales@thevalvecompany.com.au